

W-CDMA Measurement Guide

Agilent Technologies E4406A VSA Series Transmitter Tester



Agilent Technologies

Manufacturing Part Number: E4406-90132

Printed in USA

July 2000

© Copyright 1999 - 2000 Agilent Technologies, Inc.

The information contained in this document is subject to change without notice.

Agilent Technologies makes no warranty of any kind with regard to this material, including but not limited to, the implied warranties of merchantability and fitness for a particular purpose. Agilent Technologies shall not be liable for errors contained herein or for incidental or consequential damages in connection with the furnishing, performance, or use of this material.

1. Understanding W-CDMA	
What Is the W-CDMA Communications System?	10
What Does the Agilent Technologies E4406A VSA Series Transmitter Tester Do?	11
Other Sources of Measurement Information	13
Instrument Updates at www.agilent.com/find/vsa/	13
2. Setting Up the W-CDMA (3GPP) Mode	
W-CDMA (3GPP) Mode	16
How to Make a Measurement	16
Changing the Mode Setup	18
Changing the Frequency Channel	23
W-CDMA Measurement Key Flow	24
Installing Optional	
Measurement Personalities	49
Available Personality Options	50
License Key Numbers	50
Installing a License Key Number	51
Using the Uninstall Key	52
3. Making W-CDMA (3GPP) Measurements	
W-CDMA (3GPP) Measurements	54
Preparing for Measurements	55
Initial Setup	55
Measurement Selection	55
Measurement Control	57
Measurement Setup	58
Making the Channel Power Measurement	61
Purpose	61
Measurement Method	61
Making the Measurement	62
Results	62
Changing the Measurement Setup	63
Changing the Display	65
Troubleshooting Hints	66
Making the Adjacent Channel Power Ratio (ACPR) Measurement	67
Purpose	67
Measurement Method	67
Making the Measurement	68
Results	68
Changing the Measurement Setup	69
Changing the View	72
Changing the Display	74
Troubleshooting Hints	75
Making the Intermodulation Measurement	76
Purpose	76
Measurement Method	76
Making the Measurement	77
Results	77
Changing the Measurement Setup	78
Changing the View	80
Changing the Display	80
Troubleshooting Hints	81
Making the Multi Carrier Power Measurement	82

Contents

Purpose	82
Measurement Method	82
Making the Measurement	83
Results	84
Changing the Measurement Setup	85
Changing the View	87
Changing the Display	88
Using the Marker	88
Troubleshooting Hints	89
Making the Spectrum Emission Mask Measurement	90
Purpose	90
Measurement Method	90
Making the Measurement	91
Results	91
Changing the Measurement Setup	92
Changing the View	100
Changing the Display	101
Troubleshooting Hints	102
Making the Occupied Bandwidth Measurement	103
Purpose	103
Measurement Method	103
Making the Measurement	103
Results	104
Changing the Measurement Setup	105
Changing the View	106
Changing the Display	107
Using the Marker	107
Troubleshooting Hints	107
Making the Code Domain Measurement	108
Purpose	108
Measurement Method	108
Making the Measurement	110
Results	110
Changing the Measurement Setup	111
Changing the View	114
Changing the Display	117
Using the Markers	122
Using the Print Function	122
Troubleshooting Hints	123
Making the Modulation Accuracy (Composite EVM) Measurement	124
Purpose	124
Measurement Method	124
Making the Measurement	126
Results	126
Changing the Measurement Setup	127
Changing the View	129
Changing the Display	130
Using the Markers	133
Troubleshooting Hints	133
Making the QPSK EVM Measurement	134
Purpose	134
Measurement Method	134
Making the Measurement	135

Results	135
Changing the Measurement Setup	136
Changing the View	137
Changing the Display	138
Using the Markers	140
Troubleshooting Hints	141
Making the Power Stat CCDF Measurement	142
Purpose	142
Measurement Method	142
Making the Measurement	143
Results	143
Changing the Measurement Setup	144
Changing the View	145
Changing the Display	145
Using the Markers	146
Troubleshooting Hints	146
Making the Spectrum (Frequency Domain) Measurement	147
Purpose	147
Measurement Method	147
Making the Measurement	147
Results	147
Changing the Measurement Setup	149
Changing the View	152
Using the Markers	153
Troubleshooting Hints	154
Making the Waveform (Time Domain) Measurement	155
Purpose	155
Measurement Method	155
Making the Measurement	155
Results	156
Changing the Measurement Setup	157
Changing the View	160
Using the Markers	160
Troubleshooting Hints	161
4. Setting Up the W-CDMA (Trial & Arib) Mode	
W-CDMA (Trial & Arib) Mode	164
How to Make a Measurement	164
Changing the Mode Setup	166
Changing the Frequency Channel	170
W-CDMA Measurement Key Flow	171
Installing Optional	
Measurement Personalities	188
Available Personality Options	189
License Key Numbers	189
Installing a License Key Number	190
Using the Uninstall Key	191
5. Making W-CDMA (Trial & Arib) Measurements	
W-CDMA (Trial & Arib) Measurements	194
Preparing for Measurements	195
Initial Setup	195
Measurement Selection	195

Contents

Measurement Control	197
Measurement Setup	197
Making the Channel Power Measurement	200
Purpose	200
Measurement Method	200
Making the Measurement	201
Results	201
Changing the Measurement Setup	202
Changing the Display	204
Troubleshooting Hints	204
Making the Adjacent Channel Power Ratio (ACPR) Measurement	205
Purpose	205
Measurement Method	205
Making the Measurement	206
Results	206
Changing the Measurement Setup	207
Changing the View	210
Changing the Display	211
Troubleshooting Hints	212
Making a Power Statistics CCDF Measurement	213
Purpose	213
Measurement Method	213
Making the Measurement	214
Results	214
Changing the Measurement Setup	215
Changing the View	215
Changing the Display	216
Using the Markers	216
Troubleshooting Hints	217
Making the Code Domain Measurement	218
Purpose	218
Measurement Method	218
Making the Measurement	220
Results	220
Changing the Measurement Setup	221
Changing the View	224
Changing the Display	226
Using the Markers	230
Troubleshooting Hints	231
Making the QPSK EVM Measurement	232
Purpose	232
Measurement Method	232
Making the Measurement	233
Results	233
Changing the Measurement Setup	234
Changing the View	235
Changing the Display	236
Using the Markers	239
Troubleshooting Hints	239
Making the Modulation Accuracy (Rho) Measurement	240
Purpose	240
Measurement Method	240
Making the Measurement	241

Results	241
Changing the Measurement Setup	242
Changing the View	243
Changing the Display	244
Using the Markers	247
Troubleshooting Hints	247
Making the Spectrum (Frequency Domain) Measurement	248
Purpose	248
Measurement Method	248
Making the Measurement	248
Results	248
Changing the Measurement Setup	250
Changing the View	253
Using the Markers	254
Troubleshooting Hints	255
Making the Waveform (Time Domain) Measurement	256
Purpose	256
Measurement Method	256
Making the Measurement	256
Results	257
Changing the Measurement Setup	258
Changing the View	261
Using the Markers	261
Troubleshooting Hints	262

Contents

1 Understanding W-CDMA

What Is the W-CDMA Communications System?

Wideband code division multiple access (W-CDMA) is one of the popular air interface technologies for the third generation RF cellular communications systems. In this system, the cells operate asynchronously, hence it makes the mobile synchronization more complex, but offers the advantage of flexibility in placement of the base stations. Both reverse and forward transmitter power controls are implemented with 0.625 ms intervals. W-CDMA is a direct sequence spread-spectrum digital communications technique that supports wider RF bandwidths, typically from 5 to 20 MHz. The main advantages of W-CDMA over other types of communication schemes are:

- greater capacity
- immunity to signal loss and degradation due to high-level broadband interference, multipath, scattering, and fading
- power consumption of mobile stations is strictly minimized by both base station and mobile controls
- supports variable data rates up to 144 kbits/second for mobile (vehicular) data rate, up to 384 kbits/second for portable (pedestrian) data rate, and up to 2 Mbits/second for fixed installations
- provides increased security

W-CDMA uses correlative codes to distinguish one user from another. Frequency division is still used, as is done with Frequency Division Multiple Access (FDMA) and Time Division Multiple Access (TDMA), but in a much larger bandwidth such as 5 MHz or greater. An initial baseband data rate is spread to a transmitted bit rate of 3.840 Mcps, which is also called chip rate or spread data rate. W-CDMA realizes increased capacity from 1:1 frequency reuse and sectored cells. The capacity limit is soft. That is, capacity can be increased with some degradation of the error rate or voice quality.

In W-CDMA, a single user's channel consists of a specific frequency combined with a unique code. Correlative codes allow each user to operate in the presence of substantial interference. The interference is the sum of all other users on the same W-CDMA frequency, both from within and outside of the home cell, and from delayed versions of these signals. It also includes the usual thermal noise and atmospheric disturbances. Delayed signals caused by multipath are separately received and combined in W-CDMA. One of the major differences in access is that any W-CDMA frequency can be used in all sectors of all cells. This is possible because W-CDMA is designed to decode the proper signal in the presence of high interference.

What Does the Agilent Technologies E4406A VSA Series Transmitter Tester Do?

This instrument can help determine if a W-CDMA transmitter is working correctly. Installing the optional measurement personality Option BAF, two different W-CDMA modes are available in the instrument. The first mode makes measurements defined by the 3GPP (Third Generation Partnership Project) specifications. The second mode makes measurements defined by the ARIB/Trial 1998 standards.

When configured for W-CDMA (3GPP), the instrument can be used for the testing of a W-CDMA transmitter manufactured according to the documents such as TS 25.101 V3.1.0, TS 25.141 V3.1.0 and so forth. These documents define complex, multi-part measurements used to maintain an interference-free environment. For example, the documents include test methods for the power of a carrier, spectrum emission mask, intermodulation, and so forth.

The Agilent Technologies E4406A Transmitter Tester automatically makes these measurements using the measurement methods and limits defined in the documents. The detailed results displayed by the measurements allow you to analyze W-CDMA system performance. You may alter the measurement parameters for specialized analysis. For infrastructure test, the instrument will test transmitters of base stations in a non-interfering manner by means of a coupler or power splitter.

For subscriber unit test, mobiles may be measured by way of a splitter or coupler when the mobile is actively linked to a base station or base station simulator. An alternate method of mobile measurement requires that the mobile be placed in a special test mode.

This instrument makes the W-CDMA measurements as follows ([3GPP]: new measurement functions for 3GPP)

- Channel Power
- Adjacent Channel Power Ratio (ACPR)
- Intermodulation Products [3GPP]
- Multi Carrier Power [3GPP]
- Spectrum Emission Mask [3GPP]
- Occupied Bandwidth [3GPP]
- Code Domain
- Modulation Accuracy (Composite EVM and Rho)
- QPSK EVM

- Power Statistics CCDF
- Spectrum (Frequency Domain)
- Waveform (Time Domain)

Other Sources of Measurement Information

Additional measurement application information is available through your local Agilent Technologies sales and service office. The following application notes treat digital communications measurements in much greater detail than discussed in this measurement guide.

- Application Note 1298
Digital Modulation in Communications Systems - An Introduction
Agilent part number 5965-7160E
- Application Note 1311
Understanding CDMA Measurements for Base Stations and Their Components
Agilent part number 5968-0953E
- Application Note 1325
Performing cdma2000 Measurements Today
Agilent part number 5968-5858E

Instrument Updates at www.agilent.com/find/vsa/

This web location can be used to access the latest information about the transmitter tester.

Understanding W-CDMA
Other Sources of Measurement Information

W-CDMA (3GPP) Mode

You may want to install a new personality, reinstall a personality that you have previously uninstalled, or uninstall a personality. Instructions for installing and uninstalling personality options are under [“Installing Optional Measurement Personalities” on page 49](#).

At initial power up, the transmitter tester will come up in the Basic mode, with the Spectrum (frequency domain) measurement selected and the **Measure** menu displayed.

To access the W-CDMA measurement personality, press the **MODE** key and select the **W-CDMA (3GPP)** key.

If you want to set the W-CDMA mode to a known, factory default state, press **Preset**. This will preset the mode setup and all of the measurements to the factory default parameters.

NOTE

Pressing the **Preset** key does not switch instrument modes.

How to Make a Measurement

Follow the three-step procedure shown in the table below:

Step	Primary Key	Setup Key	Related Key
1. Select & setup a mode.	MODE	Mode Setup, Input, FREQUENCY Channel	System
2. Select & setup a measurement.	MEASURE	Meas Setup	Meas Control, Restart
3. Select & setup a view.	View/Trace	SPAN X Scale, AMPLITUDE Y Scale, Display, Next Window, Zoom	File, Save, Print, Print Setup, Marker, Search

Step 1. Select & setup a mode as follows, for example:

- Press the **MODE** key and select **W-CDMA (3GPP)**.
- Press the **FREQUENCY Channel** key and enter the channel frequency to be measured.
- Press the **Mode Setup** key and change the **Radio, Input, and Trigger** conditions from those default settings.

Refer to [“Changing the Mode Setup” on page 18](#) and [“Changing the Frequency Channel” on page 23](#) for further explanation.

Refer to “[Mode Setup / FREQUENCY Channel Key Flow](#)” on page 26 for the key flow diagrams.

Step 2. Select & setup a measurement as follows, for example:

- Press the **MEASURE** key to select either **Channel Power**, **ACPR (ACLR)**, **Intermod**, **Multi Channel Power**, **Spectrum Emission Mask**, **Occupied BW**, **Code Domain**, **Mod Accuracy (Composite EVM)**, **QPSK EVM**, **Power Stat CCDF**, **Spectrum (Freq Domain)**, or **Waveform (Time Domain)** to make its measurement.
- Press the **Meas Setup** key to change any of the measurement parameters from the default settings. These parameters such as **Span**, **Res BW**, **Trig Source**, **Avg Mode**, **Limits**, are decided according to the measurement selected.

Refer to “[Channel Power Measurement Key Flow](#)” on page 27 and to “[Waveform \(Time Domain\) Measurement Key Flow \(1 of 2\)](#)” on page 47 for the key flow diagrams.

Step 3. Select & setup a view as follows, for example:

- Press the **View/Trace** key to select the desired view for the current measurement.
- Press the **Next Window** key to select a window, then press the **Zoom** key to expand the window to the full display area.
- Press the **SPAN X Scale**, **AMPLITUDE Y Scale**, **Display**, and/or **Marker** keys for your desired display. However, these keys are not always available for each view.
- Press the **Restart** front-panel key or the **Restart** softkey under the **Meas Control** menu to reflect the new measurement scale settings. With this step, the scale coupling function is activated to have an appropriate graph display.

Refer to “[Channel Power Measurement Key Flow](#)” on page 27 and to “[Waveform \(Time Domain\) Measurement Key Flow \(1 of 2\)](#)” on page 47 for the key flow diagrams.

Entering a Numeric Value

Three methods are available to enter a numeric value for an active key, however, its resolution can be different depending on the method selected and the range, if any. The highest or best resolutions in general are described throughout this guide.

- **Numeric keys** - Allows you to enter a value with the highest resolution by pressing the numeric keys. The entry is terminated by pressing the **Enter** key or one of the unit keys shown.

W-CDMA (3GPP) Mode

- **RPG knob** - Allows you to continuously change the value shown on the key with the medium or highest resolution defined to the parameter by rotating this knob.
- **Step (Up/Down arrow) keys** - Allows you to change the value shown on the key with the fixed-step resolution defined to the parameter activated. While the \uparrow (up arrow) key is pressed down, for example, the value increases in multiple steps defined to the parameter.

Changing the Mode Setup

Numerous settings can be changed at the mode level by pressing the **Mode Setup** key. This will access the menu with the selections listed below. The factory default settings are shown in tables. These settings affect only the measurements in the W-CDMA (3GPP) mode.

Configuring the Radio Setting

The **Radio** key accesses the menu as follows:

- **Device** - Allows you to toggle the test device between **BTS** (Base Transmission Station) and **MS** (Mobile Station).

Radio Default Settings	
Device	BTS

Configuring the Input Setting

The **Input** key accesses the menu as follows: (You can also access this menu from the **Input** front-panel key.)

- **Input Port** - Allows you to access the menu to select one of the signal input ports: **RF**, **I/Q**, **I only**, **50 MHz Ref**, and **IF Align**.
- **RF Input Range** - Allows you to toggle the RF input range control between **Auto** and **Man** (manual). If **Auto** is chosen, the instrument automatically sets the attenuator based on the carrier power level, where it is tuned. Once you change the **Max Total Pwr** or **Input Atten** value with the RPG knob, for example, the **RF Input Range** key is automatically set to **Man**. If there are multiple carriers present, the total power might overdrive the front end. In this case you need to set the **RF Input Range** to **Man** and enter the expected maximum total power by activating the **Max Total Pwr** key. **Man** is also useful to hold the input attenuation constant for the best relative power accuracy. For single carriers it is generally recommended to set this to **Auto**.

- **Max Total Pwr** - Allows you to set the maximum total power level from the UUT (Unit Under Test). The range is -200.00 to 100.00 dBm with 0.01 dB resolution. This is the expected maximum value of the mean carrier power referenced to the output of the UUT; it may include multiple carriers. The **Max Total Pwr** setting is coupled together with the **Input Atten** and **Ext Atten** settings. Once you change the **Max Total Pwr** value with the RPG knob, for example, the **RF Input Range** key is automatically set to **Man**.
- **Input Atten** - Allows you to control the internal input attenuator setting. The range is 0 to 40 dB with 1 dB resolution. The **Input Atten** key reads out the actual hardware value that is used for the current measurement. If more than one input attenuator value is used in a single measurement, the value used at the carrier frequency will be displayed. The **Input Atten** setting is coupled to the **Max Total Pwr** setting. Once you change the **Input Atten** setting with the RPG knob, for example, the **RF Input Range** key is automatically set to **Man**.
- **Ext Atten** - Allows you to access the following menu to enter the external attenuation values. Either of the **Ext Atten** settings is coupled together with the **RF Input Range** setting, however, pressing **Ext Atten** does not switch the **RF Input Range** key to **Man**. This will allow the instrument to display the measurement results referenced to the output of the UUT.

MS - Allows you to set an external attenuation value for MS tests. The range is -50.00 to $+50.00$ dB with 0.01 dB resolution.

BTS - Allows you to set an external attenuation value for BTS tests. The range is -50.00 to $+50.00$ dB with 0.01 dB resolution.

Input Default Settings	
Input Port	RF
RF Input Range ^a	Auto
Max Total Pwr	-15.00 dBm ^b
Input Atten	0.00 dB ^b
Ext Atten:	
MS	0.00 dB
BTS	0.00 dB

a. This key is grayed out for Spectrum (frequency domain) measurements.

b. This may differ if the maximum input power is more than -15.00 dBm, or depending on the previous measurements.

NOTE

The **Max Total Pwr** and the **Input Atten** settings are coupled together. When you switch to a different measurement, the **Max Total Pwr** setting is kept constant, but the **Input Atten** setting may change if the two measurements have different mixer margins. Thus, you can directly set the transmitter tester input attenuator, or you can set it indirectly by specifying the expected maximum power at the UUT (**Max Total Pwr** setting).

Configuring the Trigger Condition

The **Trigger** key allows you: (1) to access the trigger selection menu to specify each triggering condition, (2) to modify the default trigger holdoff time using the **Trig Holdoff** key, (3) to modify the auto trigger time and to activate or deactivate the auto trigger feature using the **Auto Trig** key, and (4) to modify the period of the frame timer using the **Frame Timer** key.

NOTE

The actual trigger source is selected separately for each measurement under the **Meas Setup** key.

- **RF Burst, Video (IF Envlp), Ext Front and Ext Rear** - Pressing one of these trigger keys will access each triggering condition setup menu. This menu is used to specify the **Delay**, **Level** and **Slope** settings for each trigger source as follows:

Delay - Allows you to enter a numerical value to modify the trigger delay time. The range is -100.0 to $+500.0$ ms with $1 \mu\text{s}$ resolution. For trigger delay use a positive value, and for pre-trigger use a negative value.

Level - Allows you to enter a numerical value to adjust the trigger level depending on the trigger source selected.

For **RF Burst** selection, the key label reads as **Peak Level**. The RF level range is -25.00 to 0.00 dB with 0.01 dB resolution, relative to the peak RF signal level. The realistic range can be down to -20 dB.

For **Video (IF Envlp)** selection, the video level range is -200.00 to $+50.00$ dBm with 0.01 dB resolution at the RF input. The realistic range can be down to around -50 dBm depending on the noise floor level of the input signal.

For **Ext Front** or **Ext Rear** selection, the level range is -5.00 to $+5.00$ V with 1 or 10 mV resolution.

Slope - Allows you to toggle the trigger slope between **Pos** at the positive-going edge and **Neg** at the negative-going edge of the burst signal.

There are other keys under the **Trigger** key as follows:

- **Trig Holdoff** - Allows you to set the period of time before the next trigger can occur. The range is 0.000 μ s to 500.0 ms with 1 μ s resolution.
- **Auto Trig** - Allows you to specify a time for a trigger timeout and toggle the auto trigger function between **On** and **Off**. The range is 1.000 ms to 1.000 ks with 1 μ s resolution. If no trigger occurs by the specified time, a trigger is automatically generated.
- **Frame Timer** - Allows you to access the menu to manually control the frame timer:

Period - Allows you to set the period of the frame clock. The range is 0.000 ns to 559.0000 ms with 1 ps resolution.

Offset - Allows you to set the offset of the frame clock. The range is 0.000 to 10.00 s with 100 ns resolution over 1.000 μ s range.

Reset Offset Display - Allows you to display without any offset of the frame clock.

Sync Source - Allows you to access the menu to select one of the sources to be synchronized with.

Off - Allows you to turn the synchronizing source off for asynchronous tests.

Ext Front - Allows you to select the external input signal from the front-panel input port as the synchronizing source.

Ext Rear - Allows you to select the external input signal from the rear panel input port as the synchronizing source.

Setting Up the W-CDMA (3GPP) Mode
W-CDMA (3GPP) Mode

Trigger Default Settings	
RF Burst:	
Delay	0.000 μ s
Peak Level	-6.00 dB
Slope	Pos
Video (IF Envp):	
Delay	0.000 μ s
Level	-6.00 dBm
Slope	Pos
Ext Front:	
Delay	0.000 μ s
Level	2.00 V
Slope	Pos
Ext Rear:	
Delay	0.000 μ s
Level	2.00 V
Slope	Pos
Trig Holdoff	0.000 ms
Auto Trig	100.0 ms, On
Frame Timer:	
Period	10.00000 ms
Offset	0.000 ms
Sync Source	Off

Changing the Frequency Channel

After selecting the desired mode setup, you will need to select the desired center frequency and the center frequency step. The selections made here will apply to all measurements in the mode. Press the **FREQUENCY Channel** key to access the following menu:

- **Center Freq** - Allows you to enter a frequency that corresponds to the desired RF channel to be measured. This is the current instrument center frequency. The range is 1.000 kHz to 4.32140 GHz with 1 Hz resolution.
- **CF Step** - Allows you to enter a center frequency step to shift the measurement segment, and to toggle the step function between **Auto** and **Man**. If set to **Auto**, the **CF Step** value automatically changes according to the selection of the standard. The range is 1.000 kHz to 1.00000 GHz with 1 Hz resolution.

FREQUENCY Channel Default Settings	
FREQUENCY Channel:	
Center Freq	1.00000 GHz
CF Step	5.00000 MHz, Auto

W-CDMA Measurement Key Flow

The key flow diagrams, shown in a hierarchical manner on the following pages, represent the overall functional relationships for the front-panel keys and the keys displayed at the extreme right side of the screen. The diagrams are:

- “Mode Setup / FREQUENCY Channel Key Flow” on page 26,
- “Channel Power Measurement Key Flow” on page 27,
- “ACPR (ACLR) Measurement Key Flow” on page 28,
- “Intermodulation Measurement Key Flow” on page 29,
- “Multi Carrier Power Measurement Key Flow (1 of 2)” on page 30
- “Spectrum Emission Mask Measurement Key Flow (1 of 2)” on page 32,
- “Occupied Bandwidth Measurement Key Flow” on page 34,
- “Code Domain Measurement Key Flow (1 of 4)” on page 35
- “Modulation Accuracy Measurement Key Flow (1 of 2)” on page 39
- “QPSK EVM Measurement Key Flow (1 of 2)” on page 41
- “Power Stat CCDF Measurement Key Flow” on page 43
- “Spectrum (Freq Domain) Measurement Key Flow (1 of 3)” on page 44
- “Waveform (Time Domain) Measurement Key Flow (1 of 2)” on page 47

Use these flow diagrams as follows:

- There are some basic conventions:

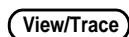
 View/Trace

An oval represents one of the front-panel keys.

 QPSK EVM

This box represents one of the keys displayed.

 <for EVM>

This represents an explanatory description on its specific key.

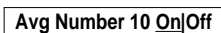
 Avg Number 10 On|Off

This box shows how the key default condition is displayed. Default parameters or values are underlined wherever possible. The values x.xx dB, for example, mean that those parameters do not have the specific default values but are automatically determined.

- Start from the extreme upper left corner of each measurement diagram to the right direction, and go from the top to the bottom.
- When defining a key from Auto with underline to Man (manual), for example, just press that key one time to toggle between Auto and Man.

- When entering a numeric value of **FREQUENCY Channel**, for example, use the numeric keypad by terminating with the appropriate unit selection from the keys displayed.
- When entering a numeric value of **Avg Number**, for example, use the numeric keypad by terminating with the **Enter** front-panel key.
- Instead of using the numeric keypad to enter a value, it may be easier to use the RPG knob or **Up/Down** arrow keys depending on the input field of a parameter.

Figure 2-1

Mode Setup / FREQUENCY Channel Key Flow

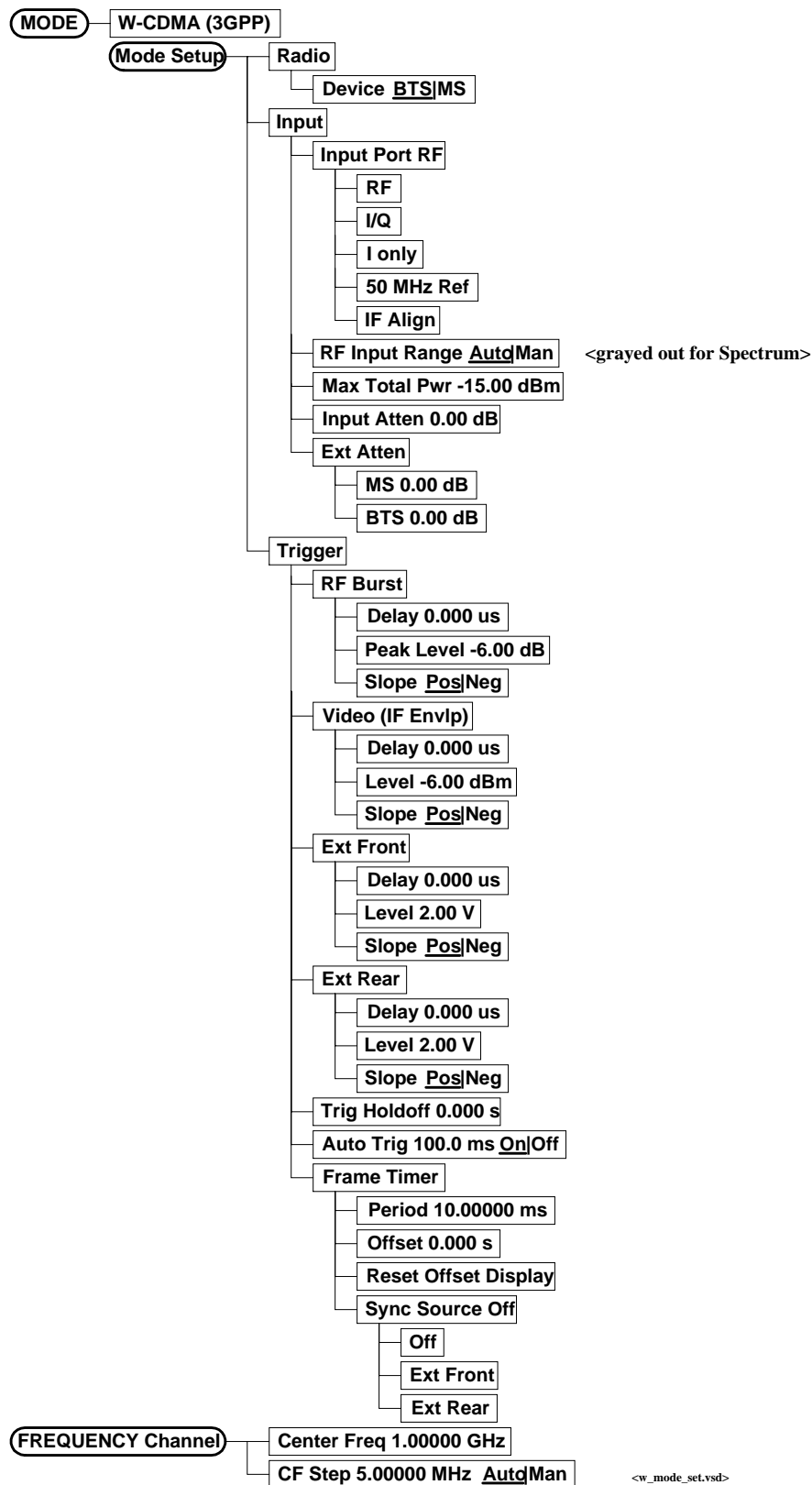

Figure 2-2 Channel Power Measurement Key Flow

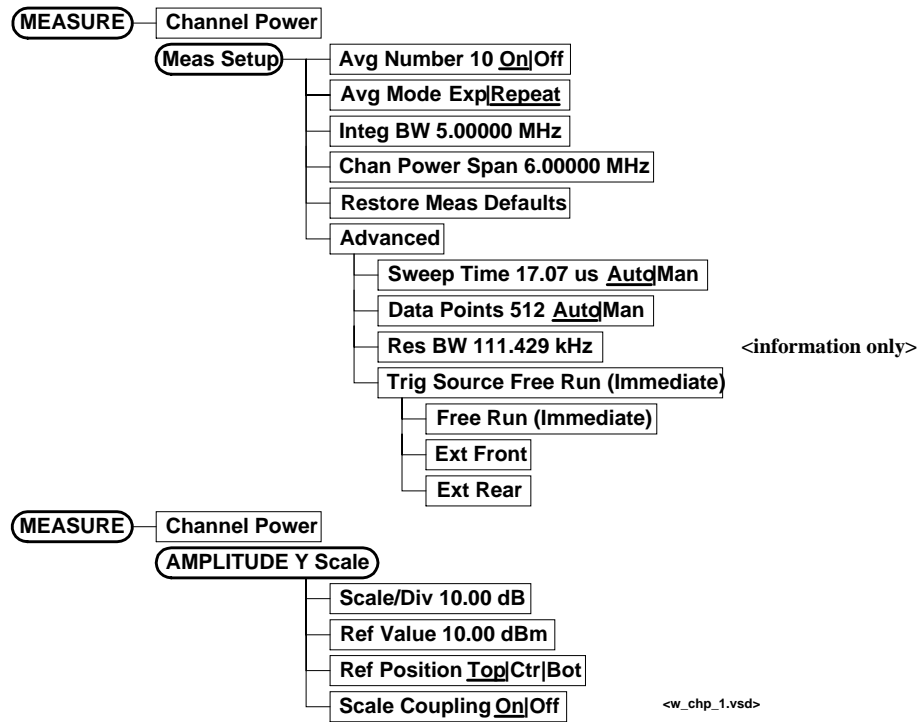

Figure 2-3 ACPR (ACLR) Measurement Key Flow

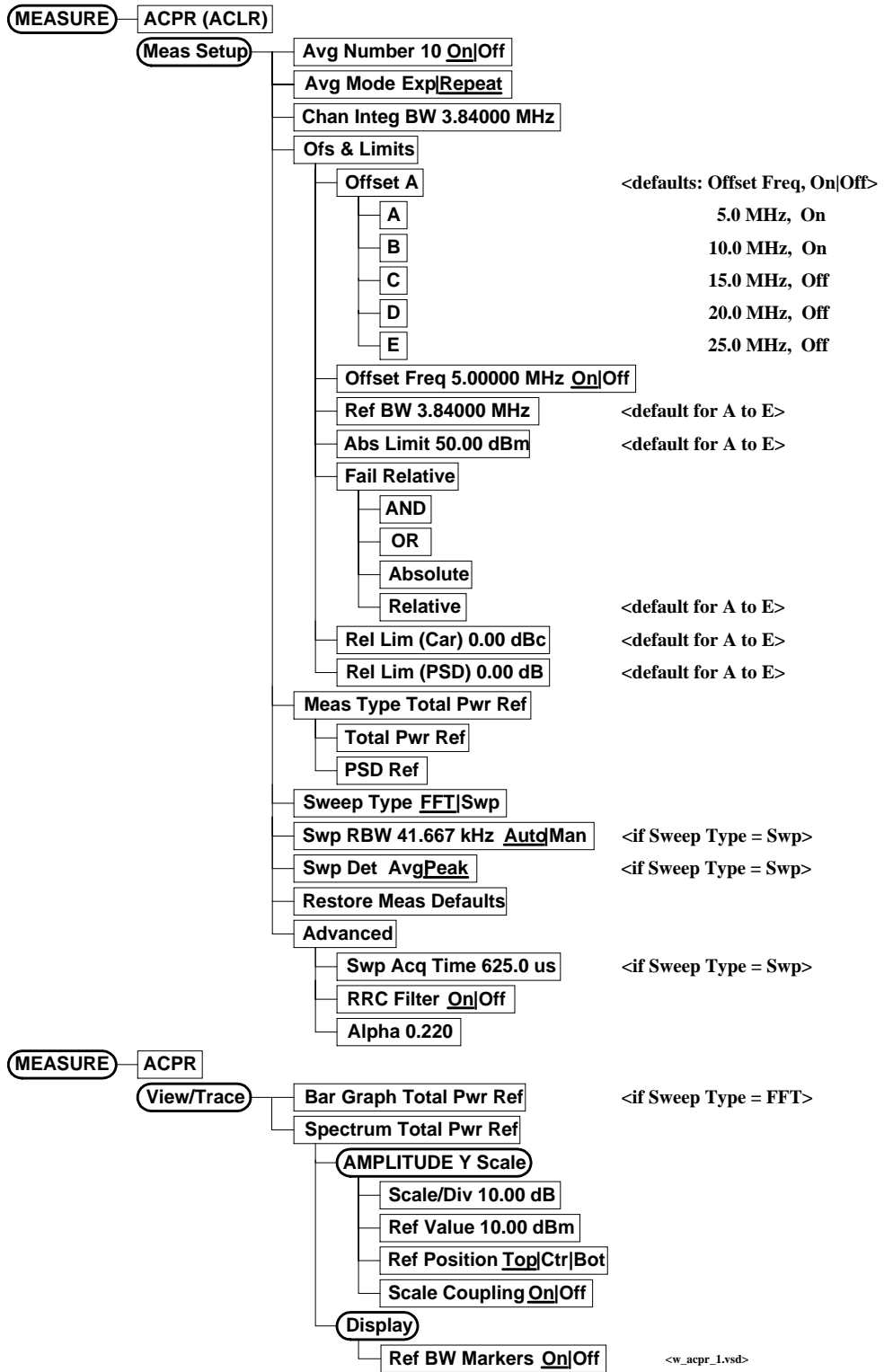
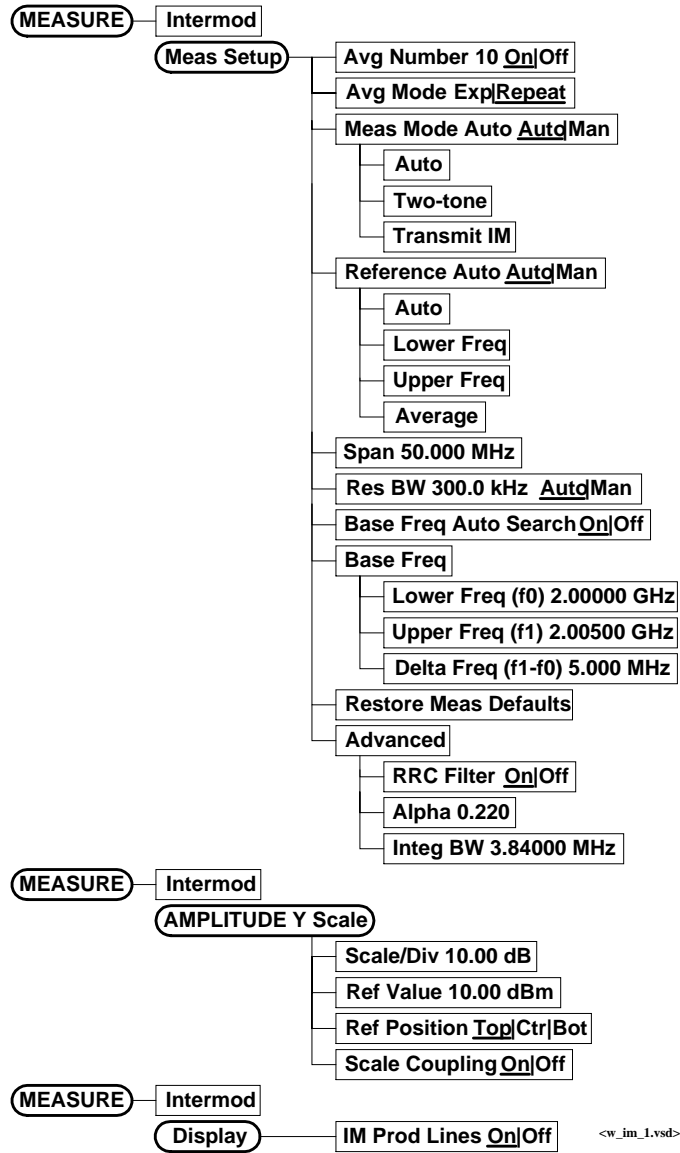

Figure 2-4 Intermodulation Measurement Key Flow



<w_im_1.vsd>

Figure 2-5 Multi Carrier Power Measurement Key Flow (1 of 2)

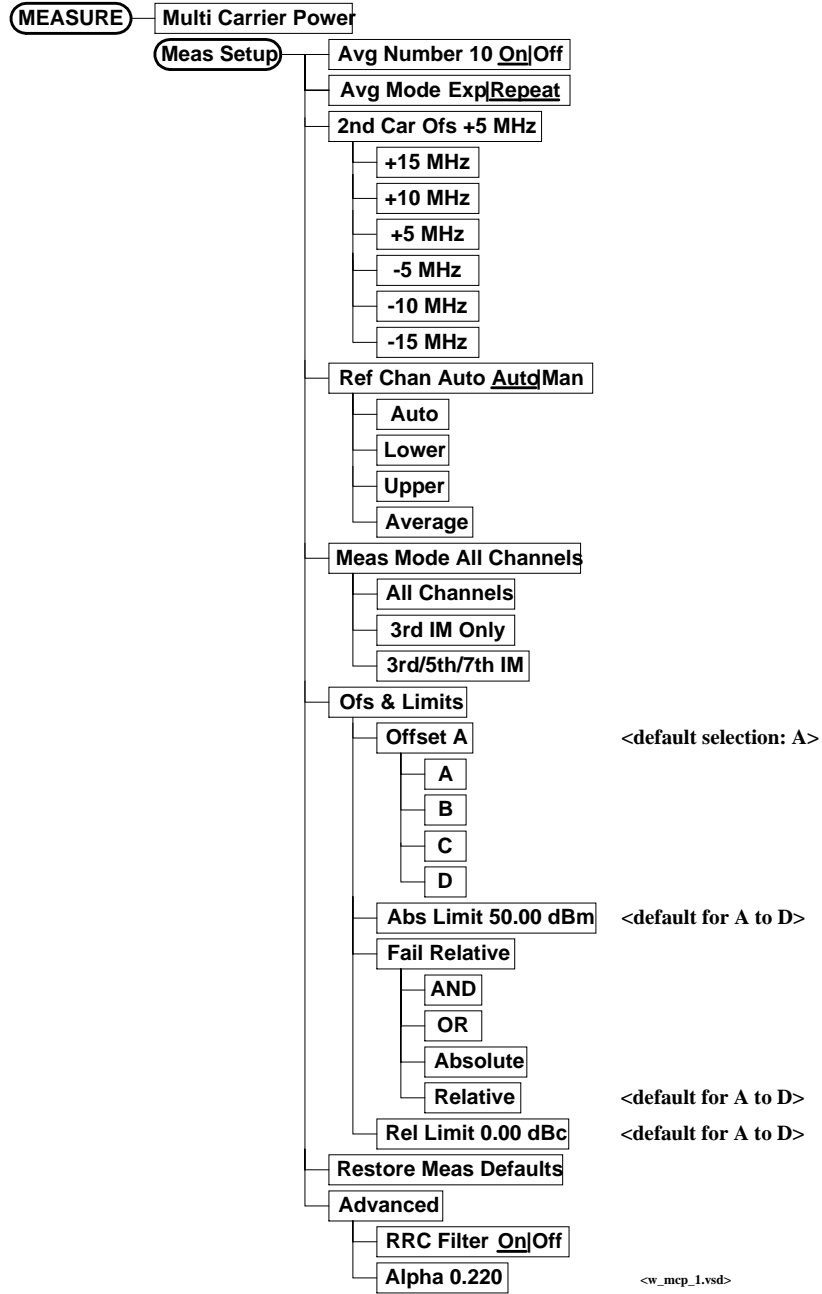

Figure 2-6

Multi Carrier Power Measurement Key Flow (2 of 2)

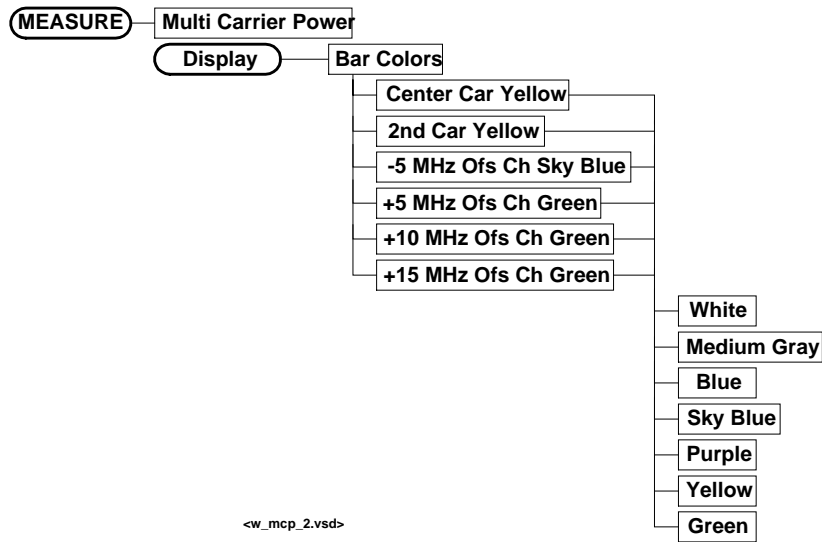

Figure 2-7 Spectrum Emission Mask Measurement Key Flow (1 of 2)

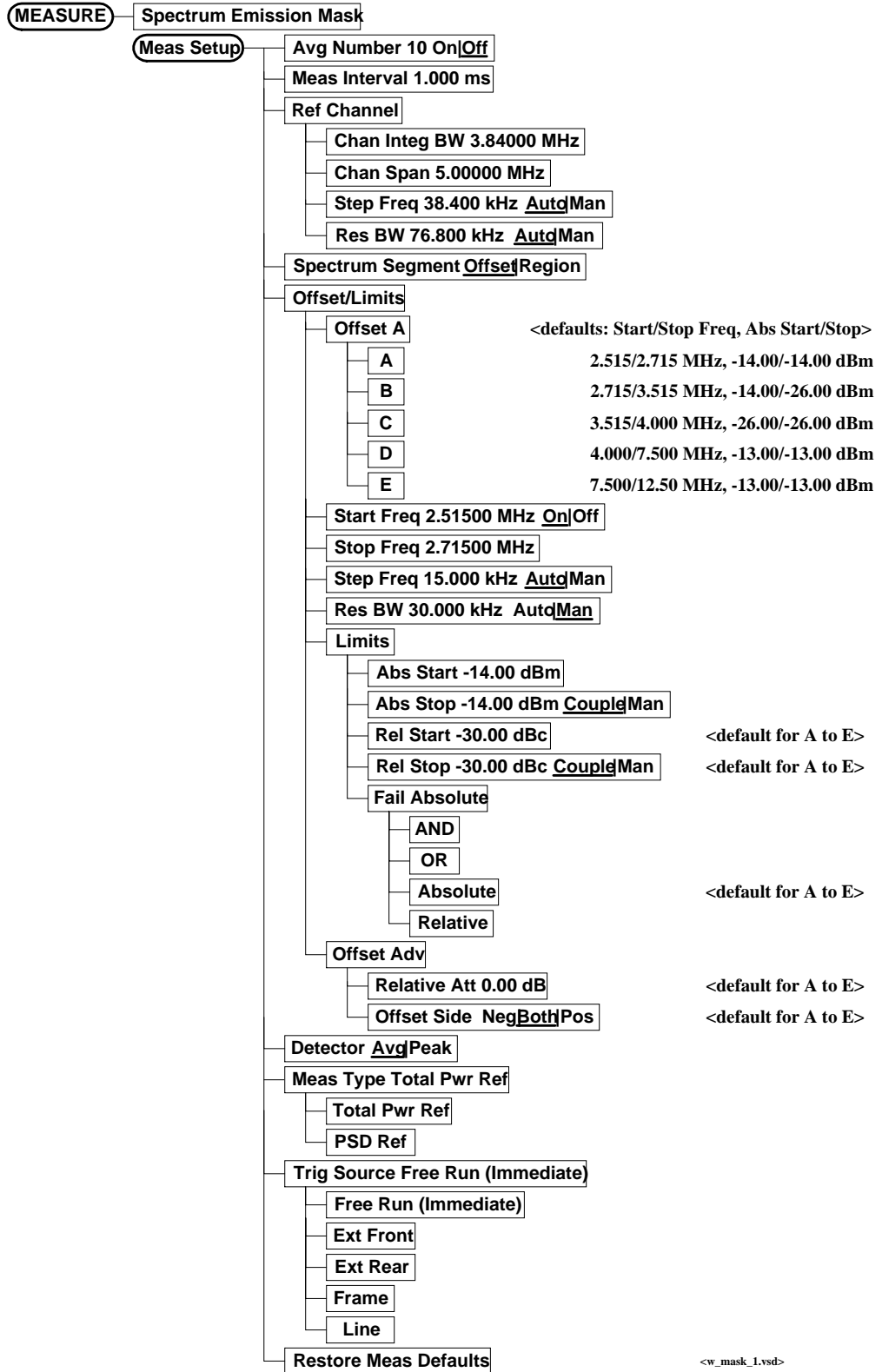

Figure 2-8 Spectrum Emission Mask Measurement Key Flow (2 of 2)

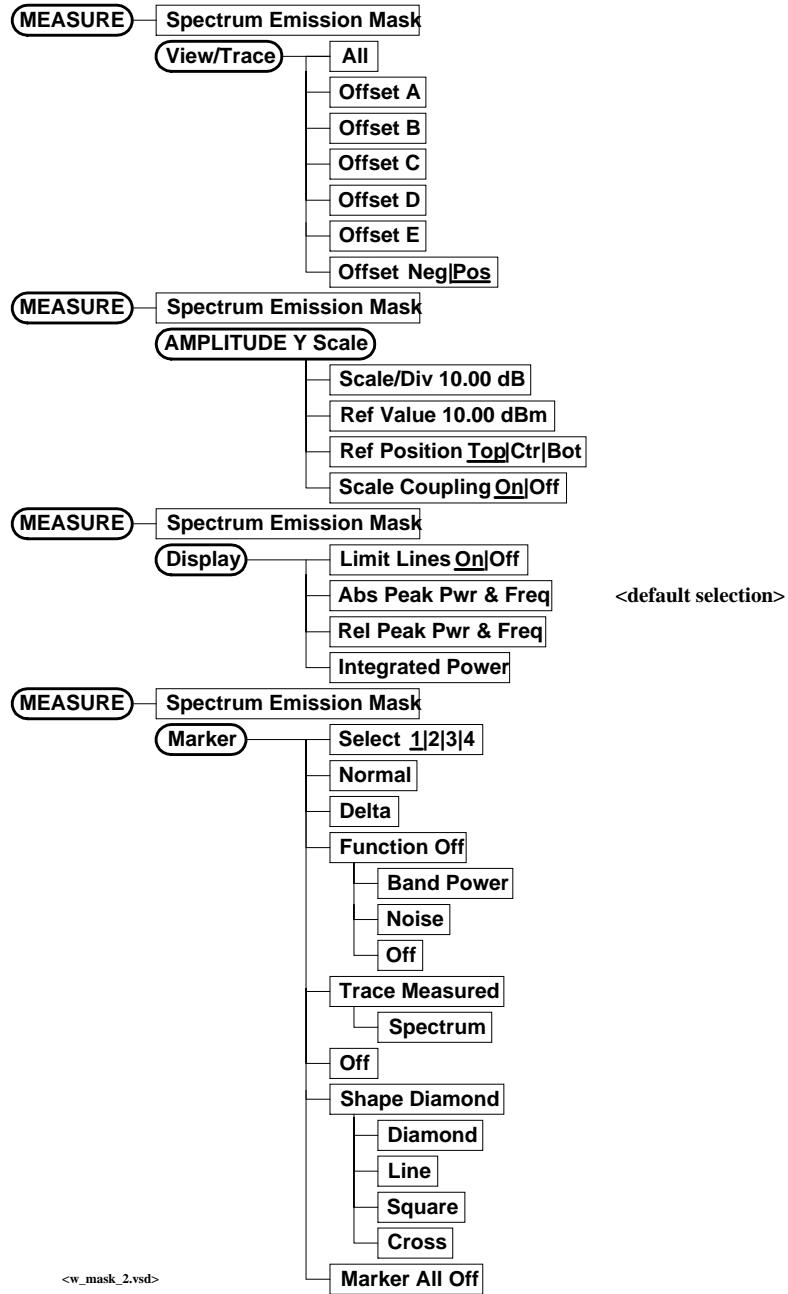
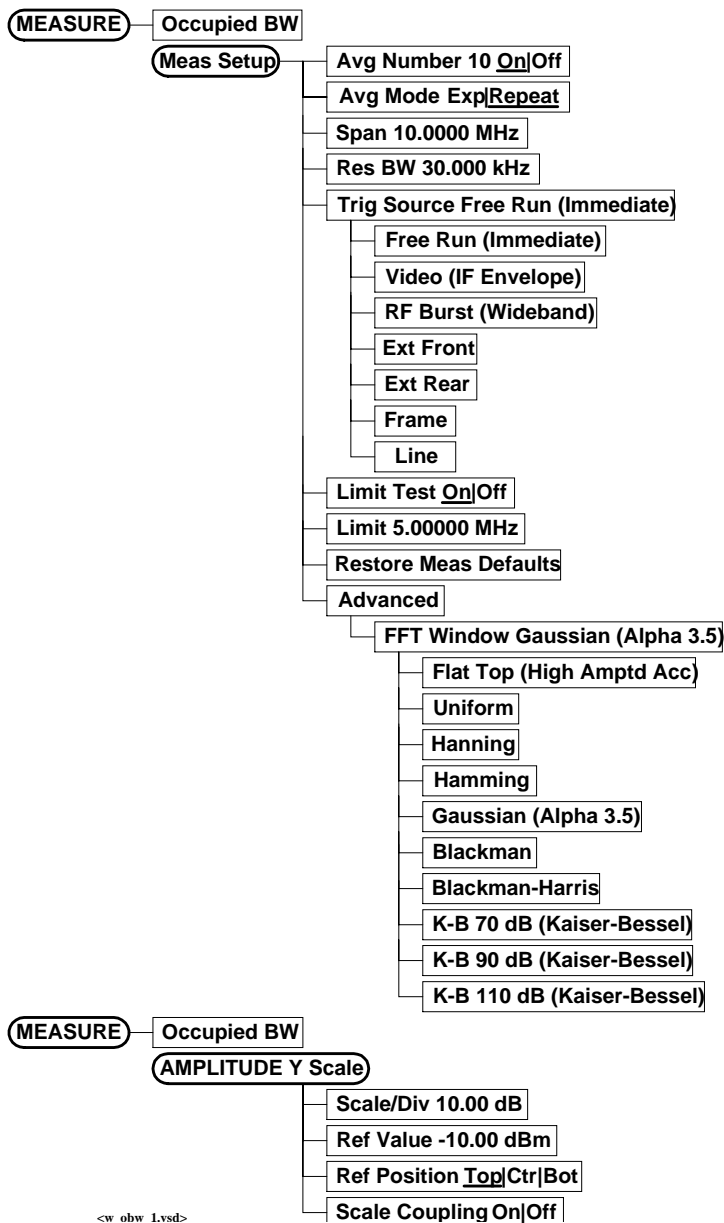

Figure 2-9 Occupied Bandwidth Measurement Key Flow



<w obw 1.vsd>

Figure 2-10 Code Domain Measurement Key Flow (1 of 4)

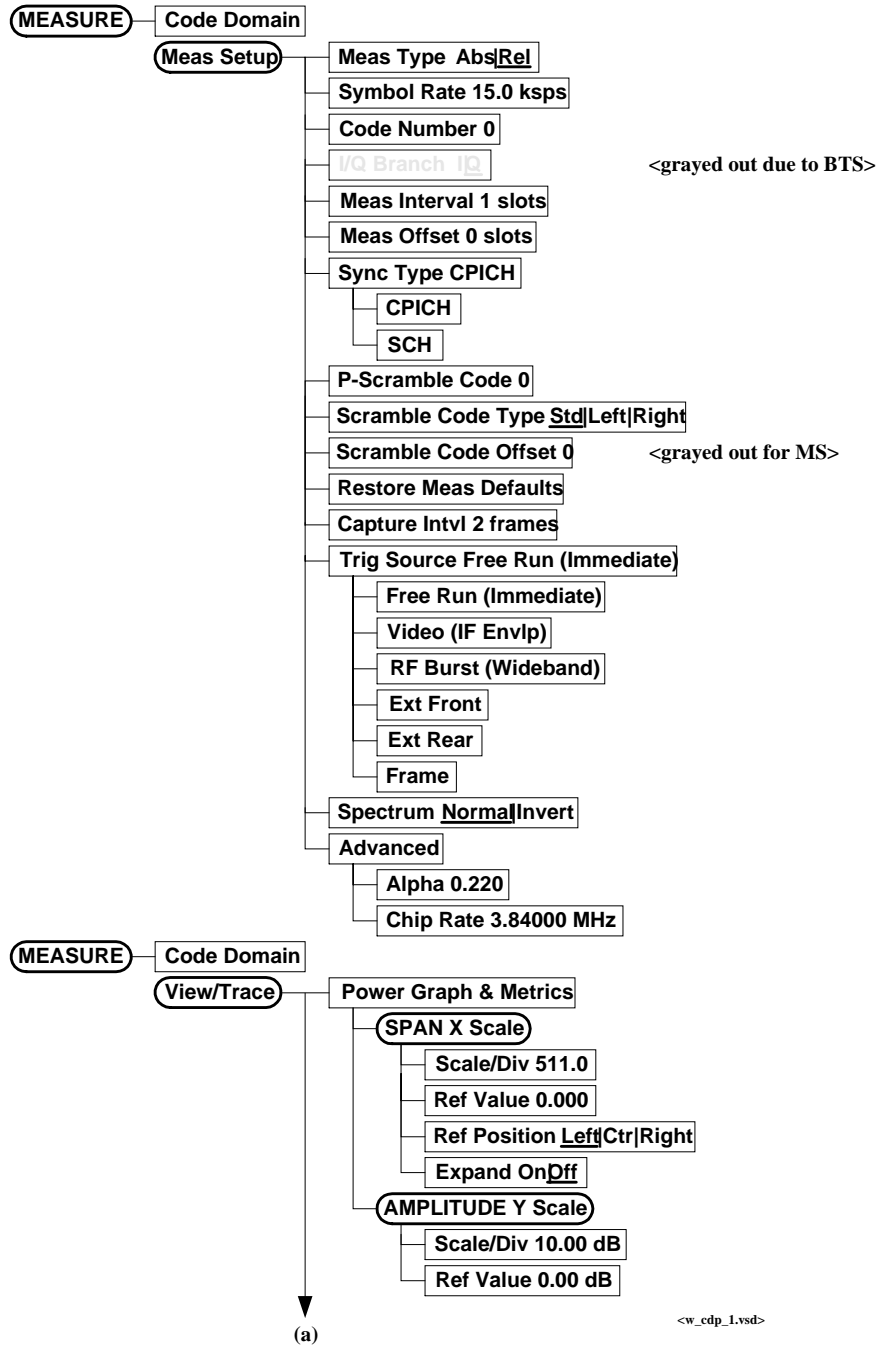

Figure 2-11 Code Domain Measurement Key Flow (2 of 4)

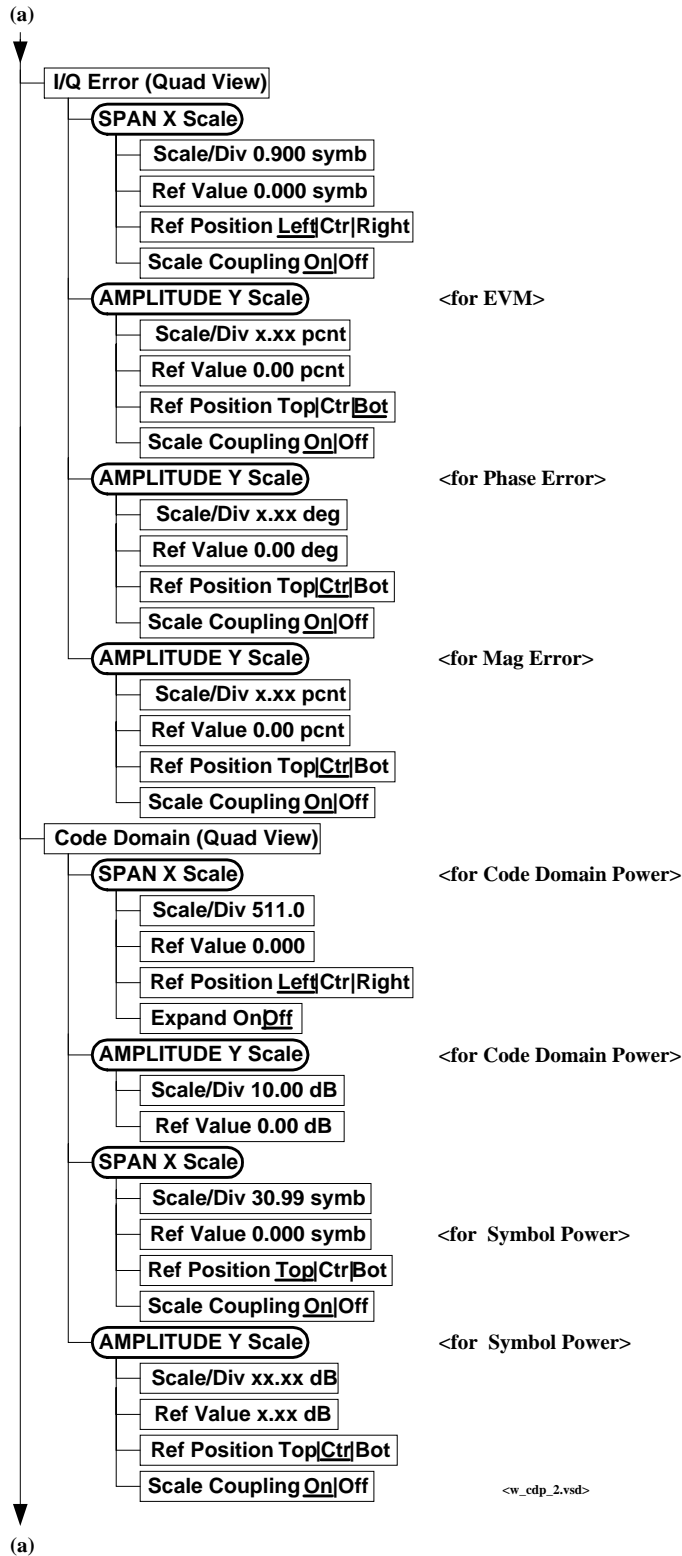

Figure 2-12 Code Domain Measurement Key Flow (3 of 4)

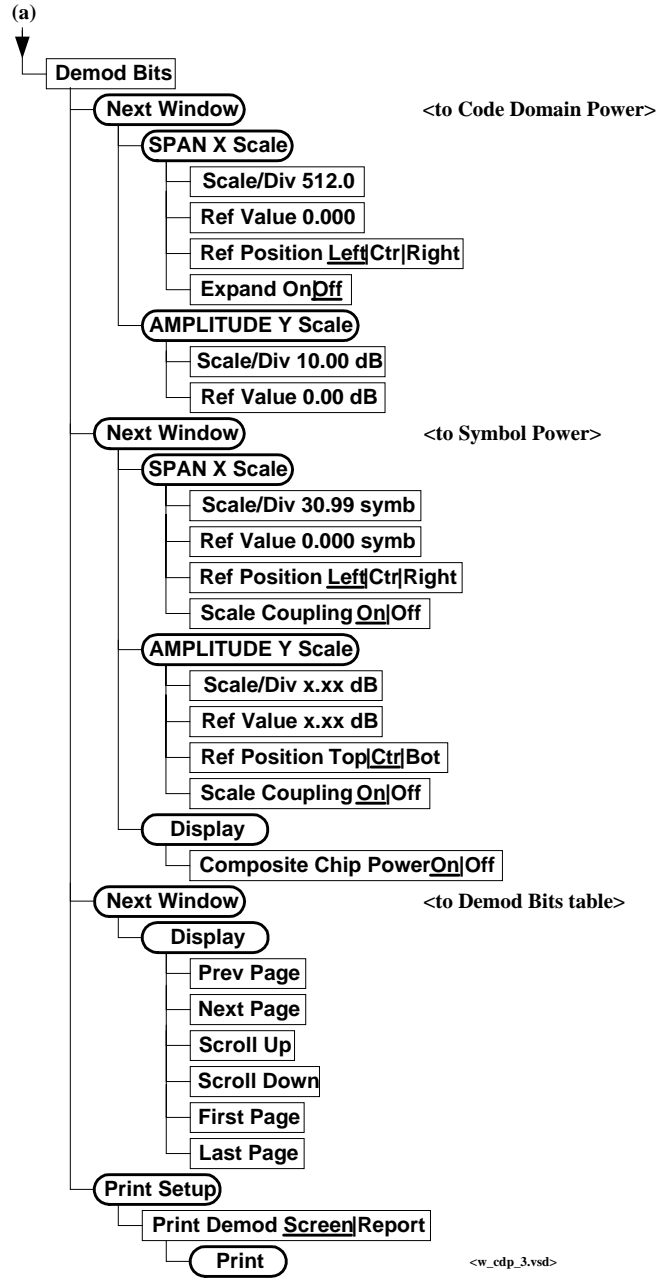

Figure 2-13 Code Domain Measurement Key Flow (4 of 4)

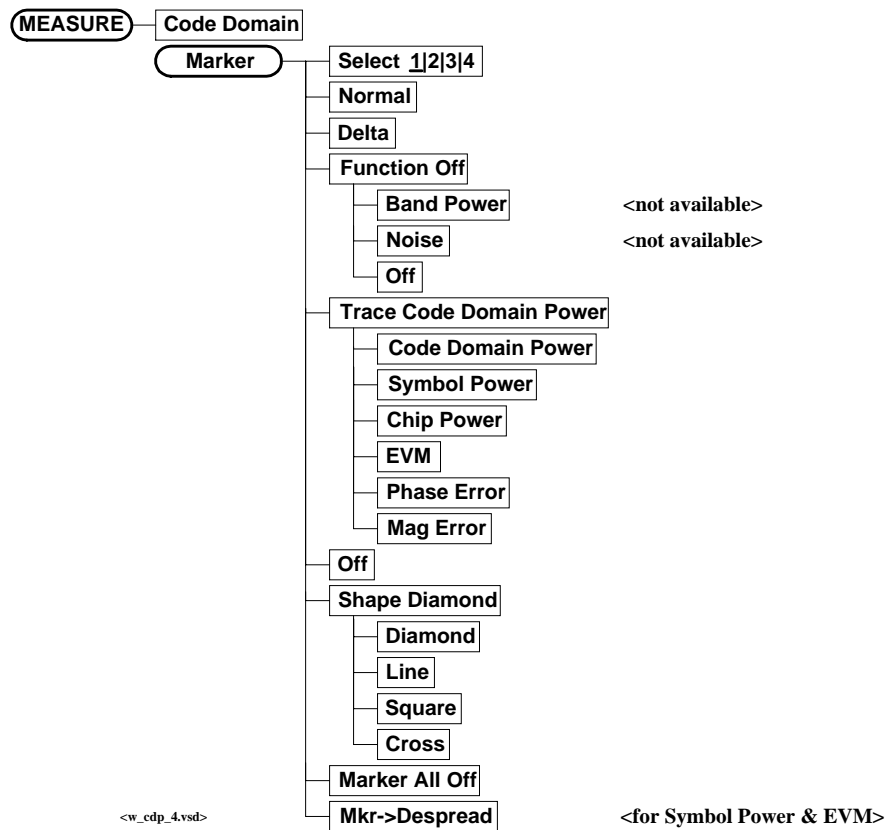

Figure 2-14 Modulation Accuracy Measurement Key Flow (1 of 2)

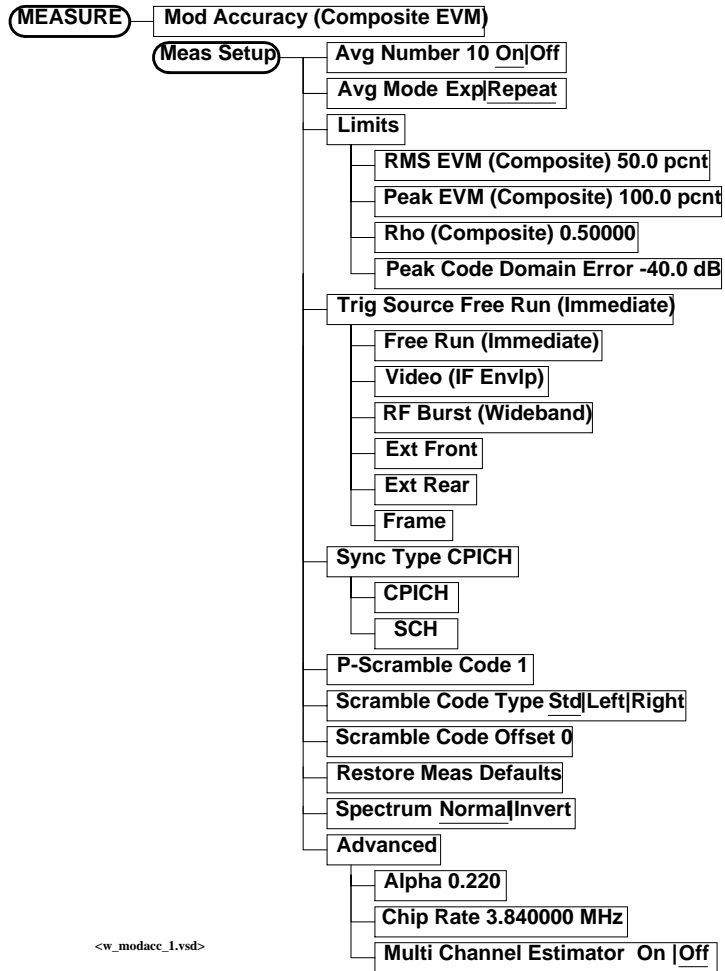

Figure 2-15 Modulation Accuracy Measurement Key Flow (2 of 2)

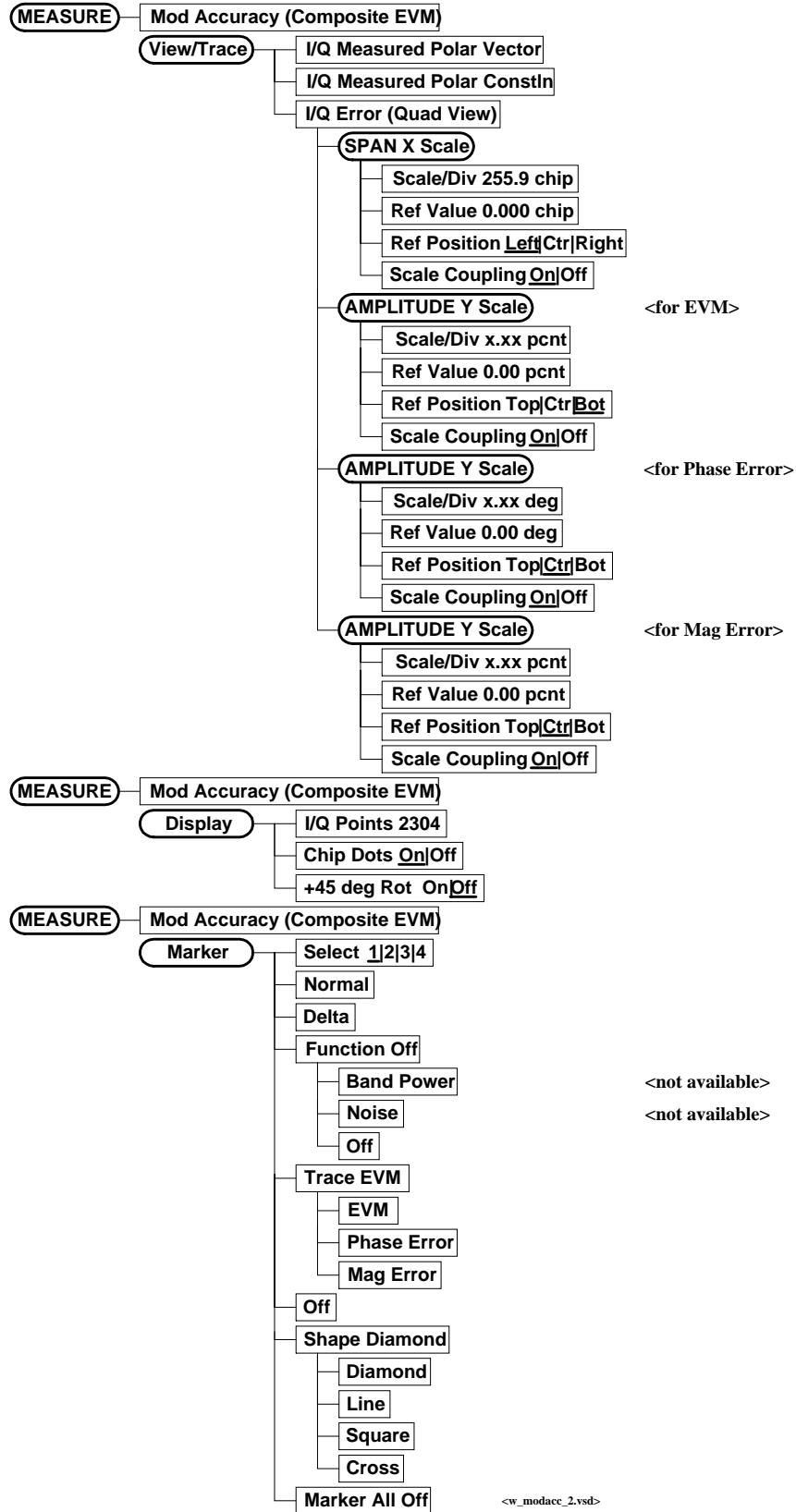

Figure 2-16 QPSK EVM Measurement Key Flow (1 of 2)

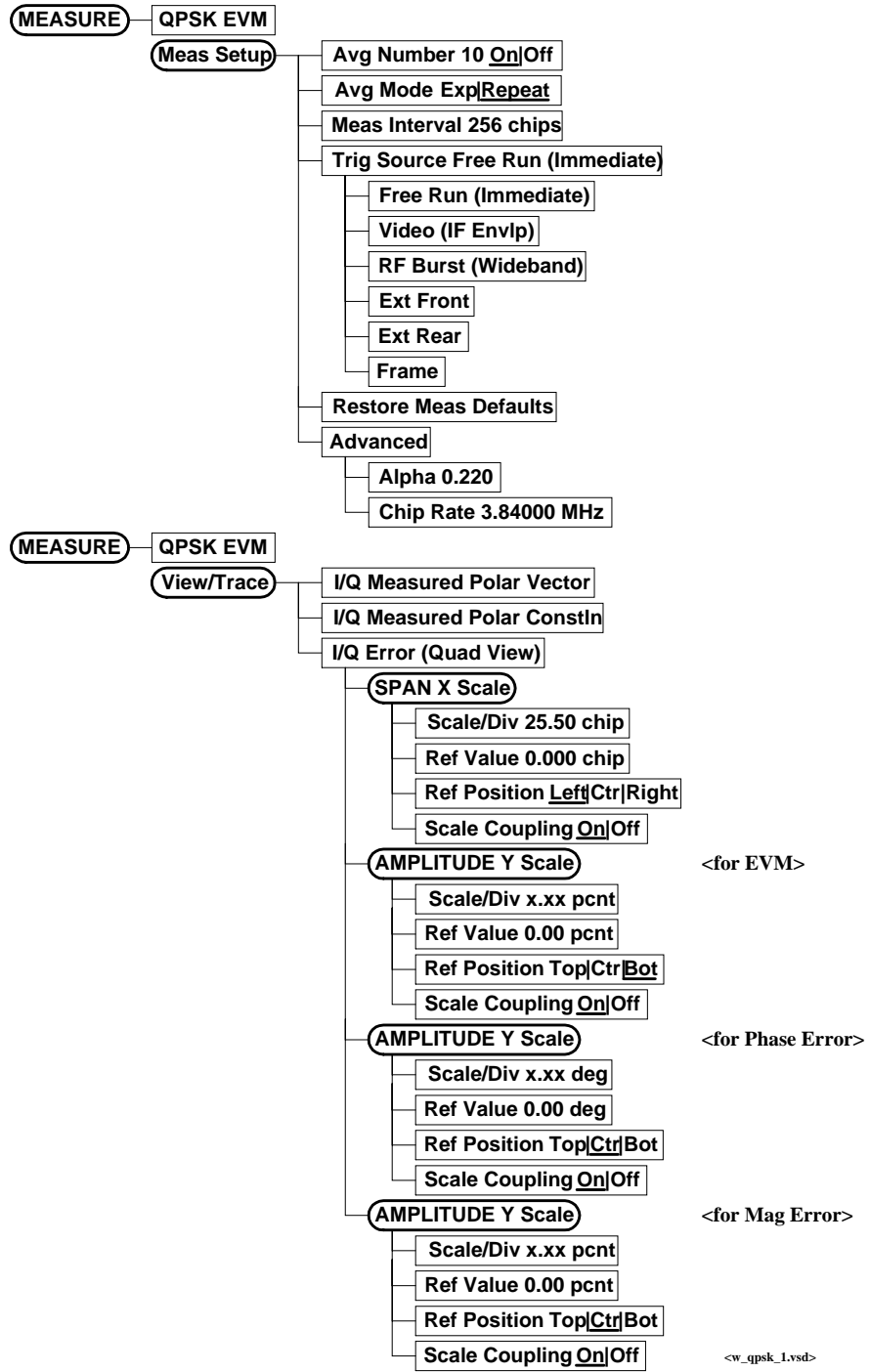

Figure 2-17 QPSK EVM Measurement Key Flow (2 of 2)

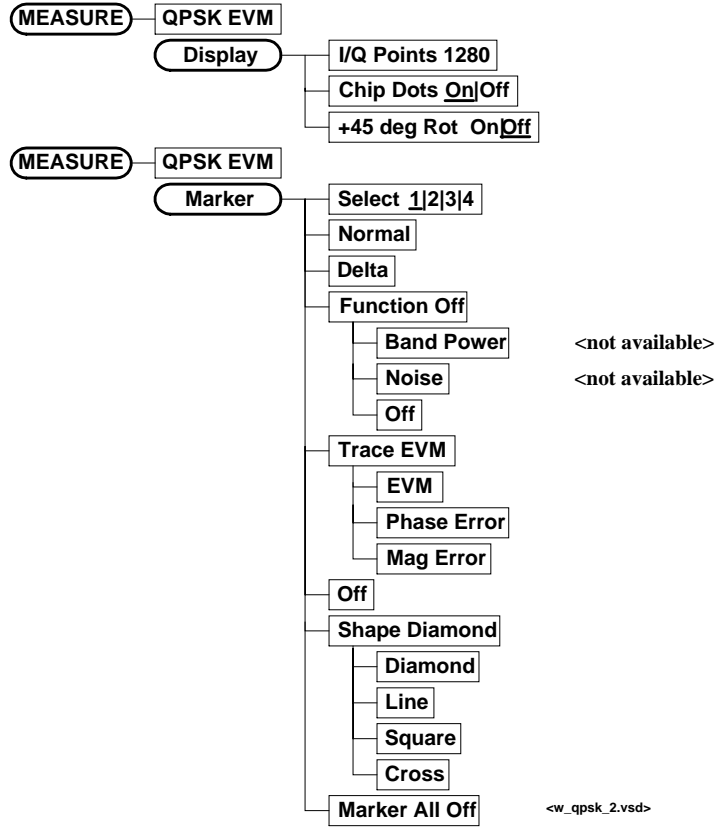

Figure 2-18 Power Stat CCDF Measurement Key Flow

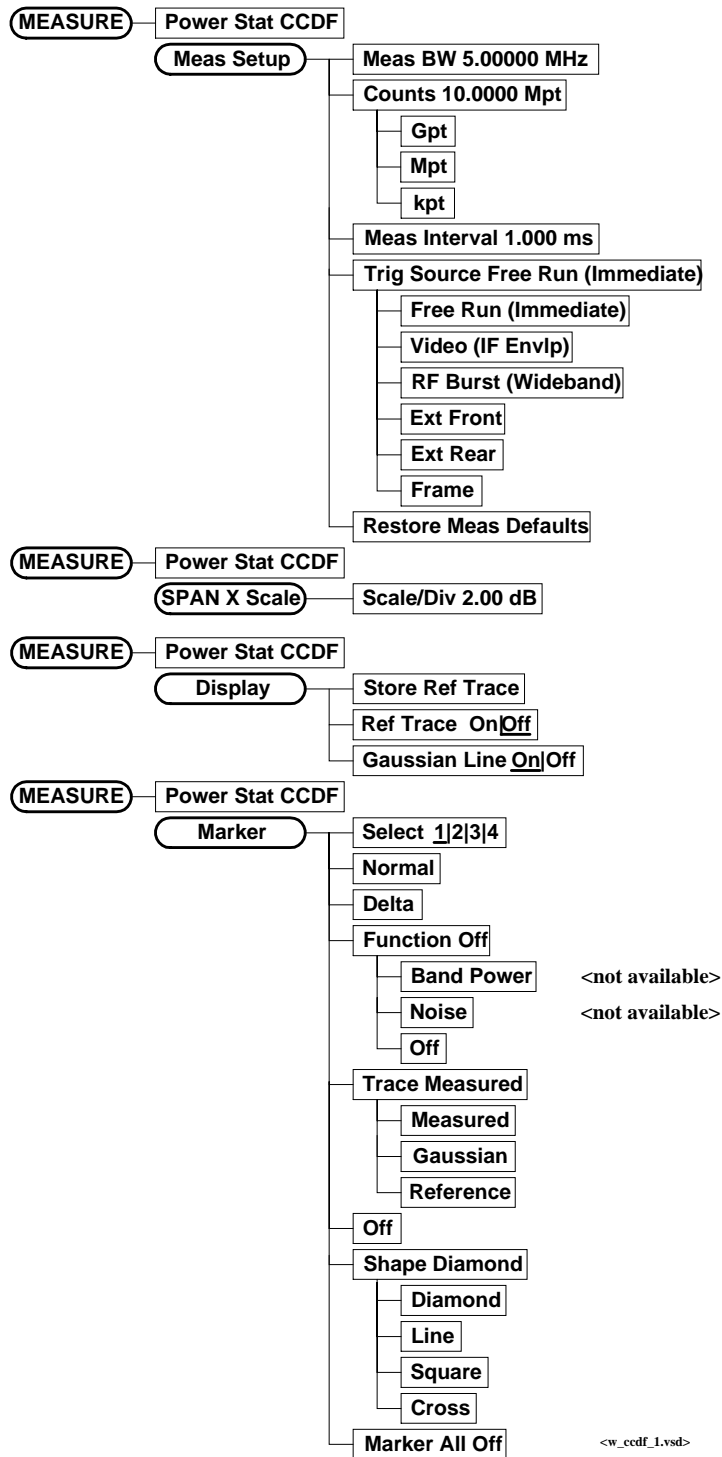

Figure 2-19 Spectrum (Freq Domain) Measurement Key Flow (1 of 3)

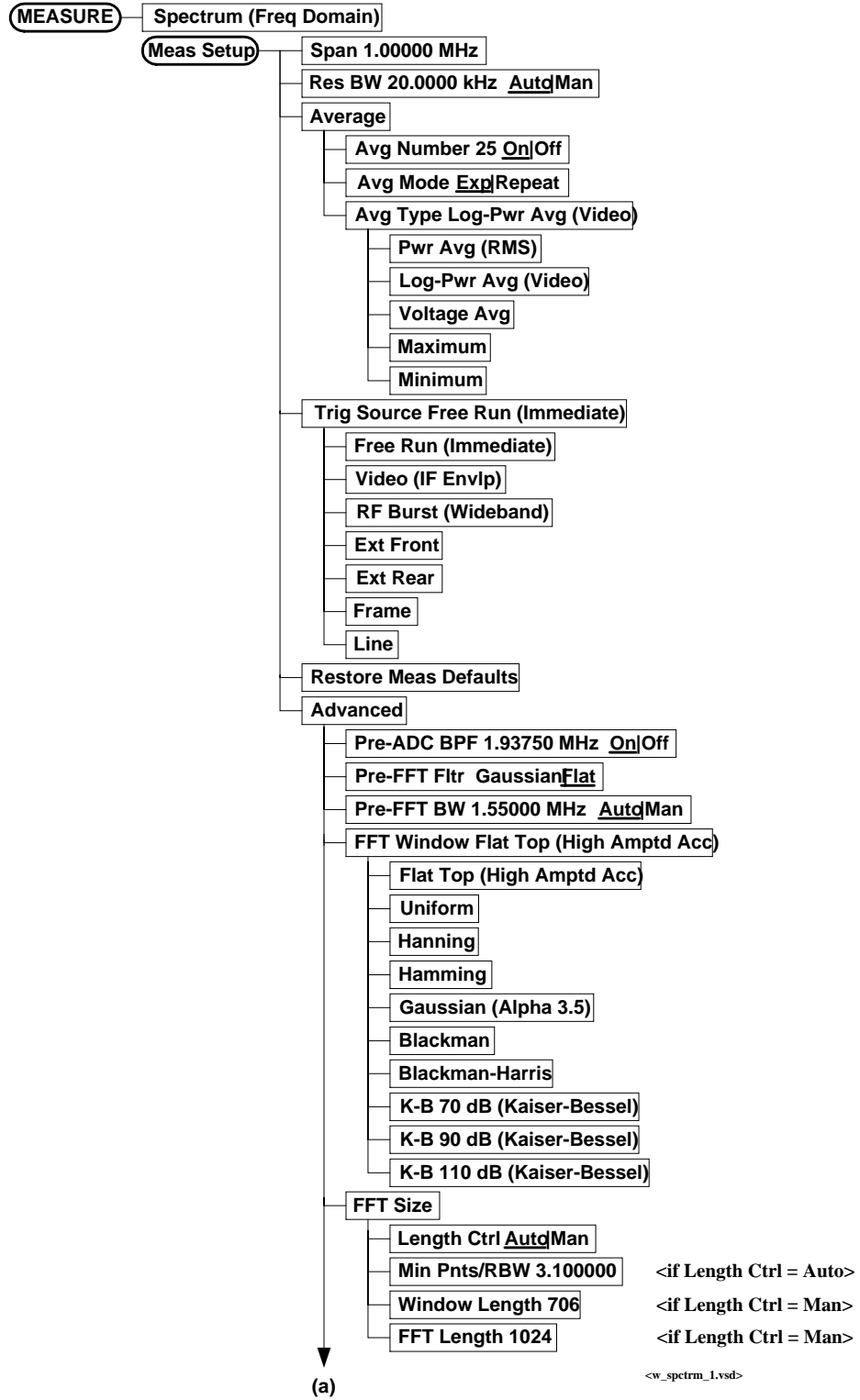

Figure 2-20 Spectrum (Freq Domain) Measurement Key Flow (2 of 3)

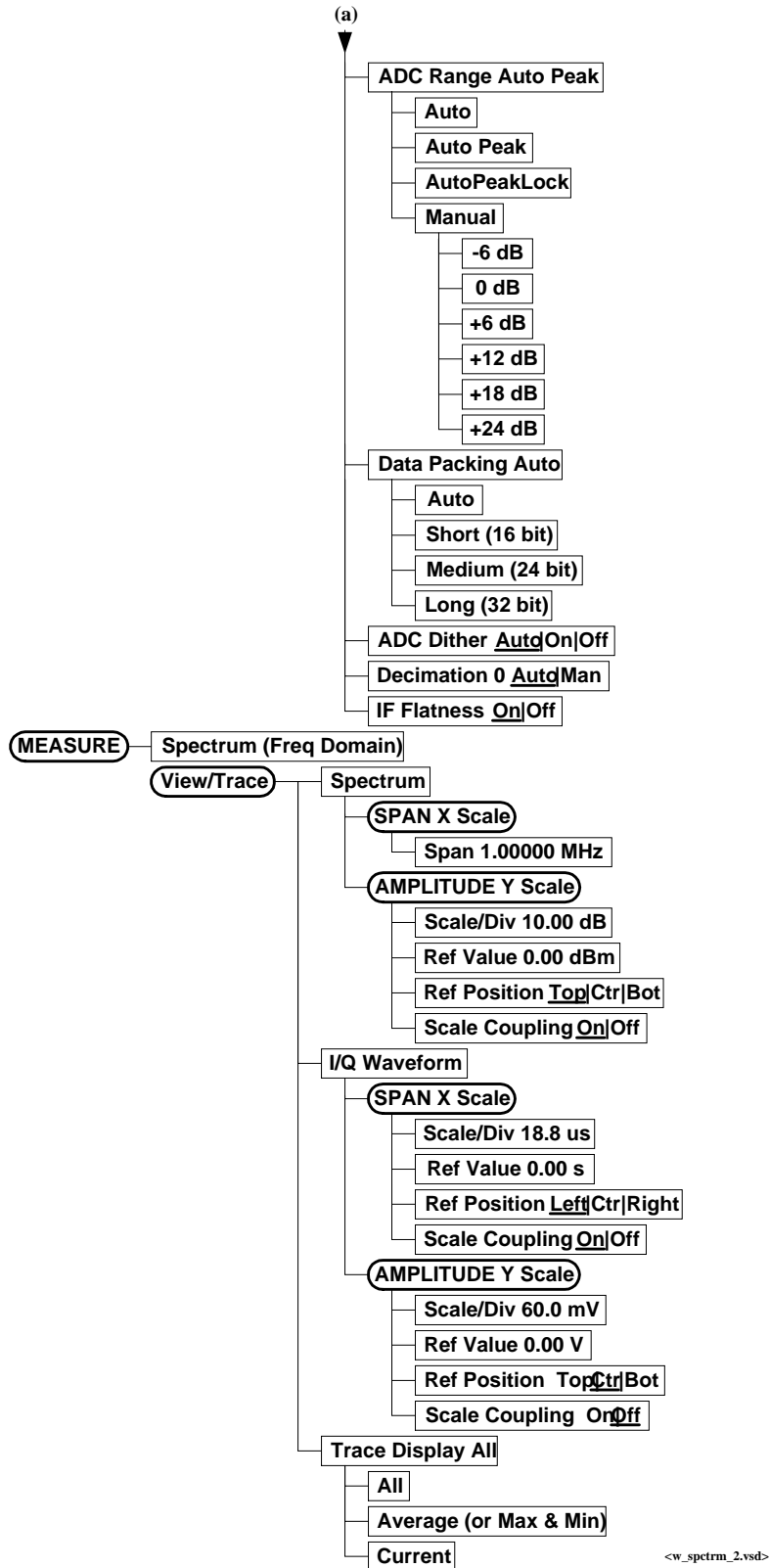

Figure 2-21 Spectrum (Freq Domain) Measurement Key Flow (3 of 3)

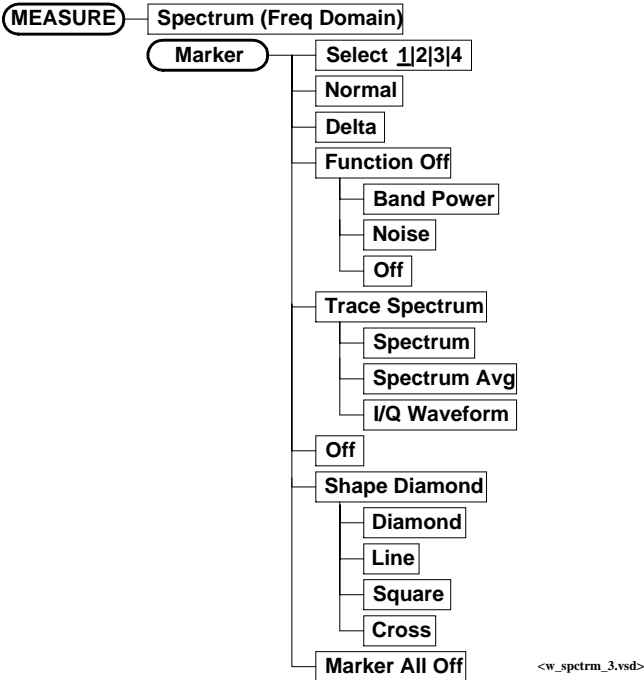

Figure 2-22 Waveform (Time Domain) Measurement Key Flow (1 of 2)

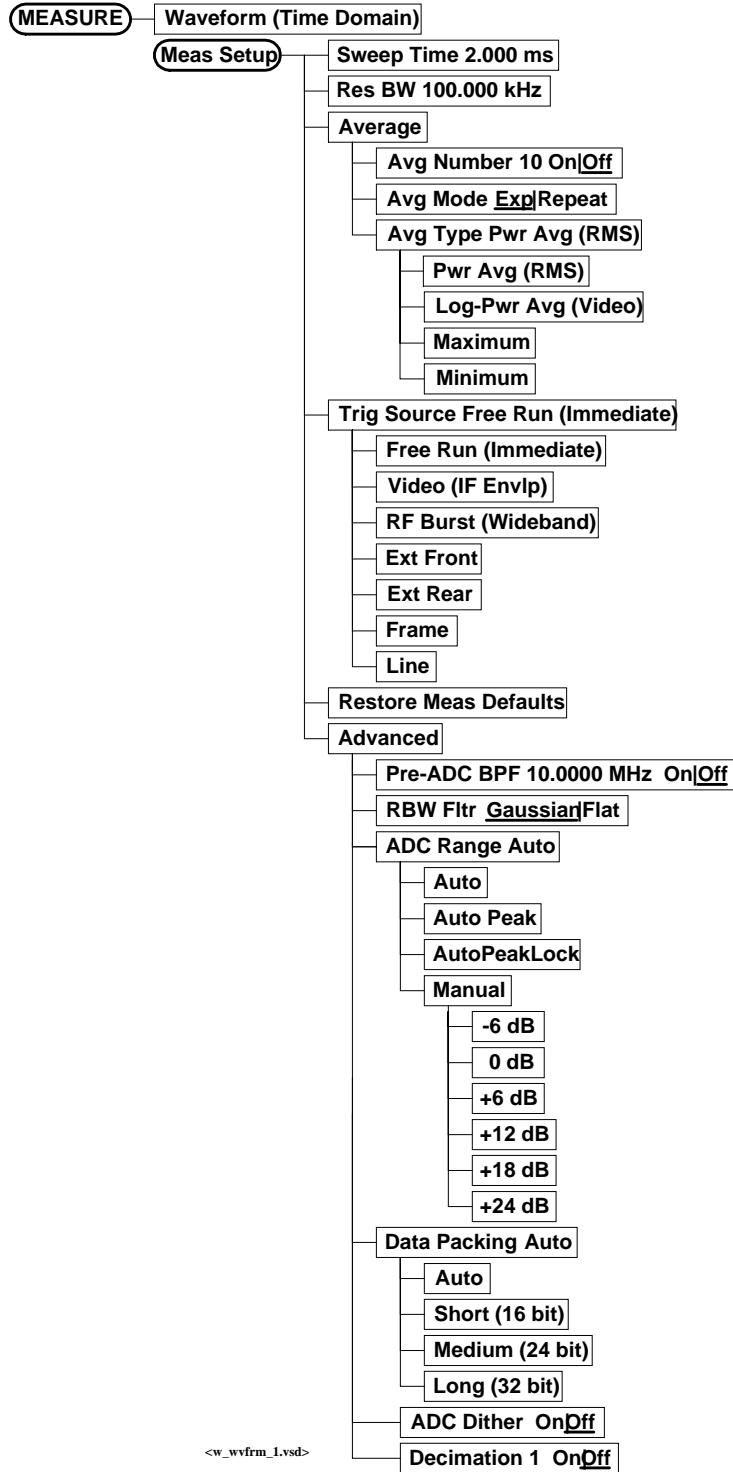
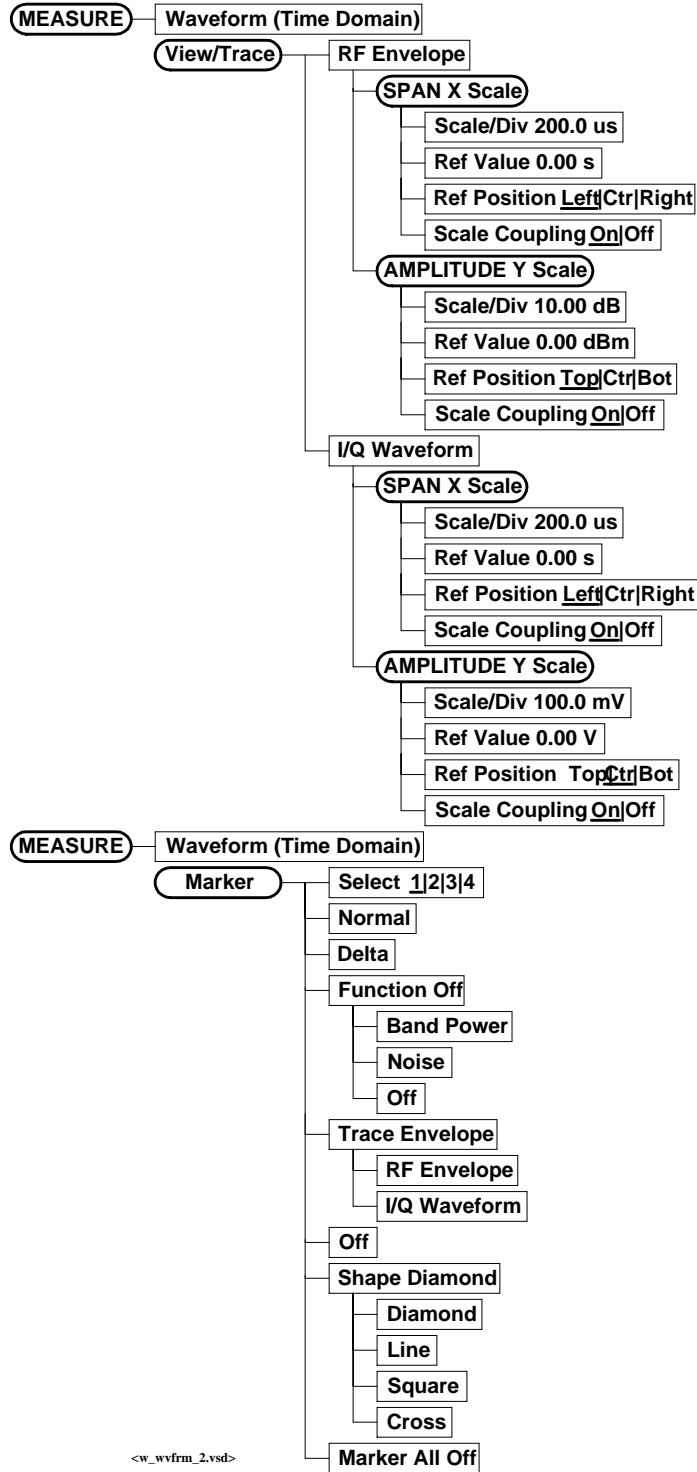

Figure 2-23 Waveform (Time Domain) Measurement Key Flow (2 of 2)



Installing Optional Measurement Personalities

When you Install a measurement personality, you follow a two step process.

1. Install the measurement personality firmware into the instrument. (See the supplied installation instructions.)
2. Enter a license key number to enable the measurement personality. (Refer to the “License Key Numbers” section below.)

Adding additional measurement personalities requires purchasing a retrofit kit for the desired option. The retrofit kit contains the measurement personality firmware. A license key certificate is also included in the kit. It documents the license key number that is for your specific option and instrument serial number. Installation instructions are included with the retrofit kit.

The installation instructions require you to know three pieces of information about your instrument: the amount of memory installed, the Host ID, and the instrument serial number.

Required information:	Key Path:
Instrument Memory: _____	System, File System (the amount of memory in your instrument will be the sum of the <i>Used</i> memory and the <i>Free</i> memory)
Host ID: _____	System, Show System, Host ID
Instrument Serial Number: _____	System, Show System, Serial Number

The Exit Main Firmware key is used during the firmware installation process. This key is only for use when you want to update firmware using a LAN connection. The **Exit Main Firmware** key halts the operation of the instrument firmware so you can install an updated version of firmware using a LAN connection. Instructions for loading future firmware updates are available at the following URL:

www.agilent.com/find/vsa/

Available Personality Options

The option designation consists of three characters, as shown in the Option column of the table below.

Available Personality Options ^a	Option
GSM measurement personality	BAH
EDGE (with GSM) measurement personality ^b	202
cdmaOne measurement personality	BAC
NADC, PDC measurement personalities	BAE
iDEN measurement personality	HN1
W-CDMA measurement personality	BAF
cdma2000 measurement personality	B78

a. Available as of the print date of this guide.

b. For instruments that already have Option BAH licensed, order E4406AU Option 252 to add EDGE (with GSM).

License Key Numbers

Measurement personalities purchased with your instrument have been installed and enabled at the factory. You will receive a unique License Key number with every measurement personality purchased. The license key number is a hexadecimal number that is for your specific measurement personality and instrument serial number. It enables you to install, or reactivate that particular personality.

Follow these steps to display the unique license key number for the measurement personality that is installed in your instrument:

1. Press **System, Install, Choose Option**. The **Choose Option** key accesses the alpha editor. Use the alpha editor to enter letters (upper-case) and the front-panel numeric keys to enter digits for a personality option that is already installed in the instrument.
2. Press the **Done** key on the alpha editor menu. The unique license key number for your instrument will now appear on the **License Key** softkey.

You will want to keep a copy of your license key number in a secure location. Please enter your license key numbers below for future reference. If you should lose your license key number, call your nearest Agilent Technologies service or sales office for assistance.

License Key Numbers for Instrument with Serial # _____
For Option _____ the license key number is _____
For Option _____ the license key number is _____
For Option _____ the license key number is _____
For Option _____ the license key number is _____
For Option _____ the license key number is _____
For Option _____ the license key number is _____

If you purchase an option later, you will receive a certificate that indicates the unique license key number that you will need to install that option on your particular serial number instrument.

NOTE

You will need to enter a license key number only if you purchase an additional measurement personality at a later date, or if you want to reactivate a measurement personality that has been deactivated.

Installing a License Key Number

NOTE

Follow this procedure to reinstall a license key number which has been deleted during the uninstall process, or lost due to a memory failure.

To install a license key number for the selected option, use the following procedure:

1. Press **System, Install, Choose Option**. The **Choose Option** key accesses the alpha editor menu. Use the alpha editor to enter letters (upper-case) and the front-panel numeric keys to enter numbers for the option designation. Then press the **Done** key. As you enter the option, you will see your entry in the active function area of the display.

Note: that you must already have entered the license key for the GSM option BAH before you can enter the license key for the EDGE retrofit option 252.

2. Press **License Key**. Use the alpha editor to enter letters and the front-panel numeric keys to enter digits. You will see your entry in the active function area of the display. When you have completed entering the license key number, press the **Done** key.

3. Press the **Install Now** key after you have entered the personality option number and the license key number. On some instruments, a message may appear in the function area of the display which reads, "Insert disk and power cycle the instrument". Disregard this message. If you want to proceed with the installation, press the **Yes** key and cycle the instrument power off and then on. Press the **No** key if you wish to cancel the installation process.

Using the Uninstall Key

The following procedure removes the license key number for the selected option. This will make the option unavailable for use, and the message "Application Not Licensed" will appear in the Status/Info bar at the bottom of the display. Please write down the 12-digit license key number for the option before proceeding. If that measurement personality is to be used at a later date you will need the license key number to reactivate the personality firmware.

NOTE

Using the Uninstall key does not remove the personality from the instrument memory, and does not free memory to be available to install another option. If you need to free memory to install another option, refer to the instructions for loading firmware updates located at the URL: www.agilent.com/find/vsa/

1. Press **System, More(1 of 3), More(2 of 3), Uninstall, Choose Option**. Pressing the **Choose Option** key will activate the alpha editor menu. Use the alpha editor to enter the letters (upper-case) and the front-panel numeric keyboard to enter the digits (if required) for the option, then press the **Done** key. As you enter the option, you will see your entry in the active function area of the display.
2. Press the **Uninstall Now** key after you have entered the personality option. Press the **Yes** key if you want to continue the uninstall process. Press the **No** key to cancel the uninstall process.
3. Cycle the instrument power off and then on to complete the uninstall process.

3 **Making W-CDMA (3GPP)
Measurements**

W-CDMA (3GPP) Measurements

Once in the W-CDMA (3GPP) mode, the following measurements are available by pressing the **MEASURE** key:

- “Making the Channel Power Measurement” on page 61
- “Making the Adjacent Channel Power Ratio (ACPR) Measurement” on page 67
- “Making the Intermodulation Measurement” on page 76
- “Making the Multi Carrier Power Measurement” on page 82
- “Making the Spectrum Emission Mask Measurement” on page 90
- “Making the Occupied Bandwidth Measurement” on page 103
- “Making the Code Domain Measurement” on page 108
- “Making the Modulation Accuracy (Composite EVM) Measurement” on page 124
- “Making the QPSK EVM Measurement” on page 134
- “Making the Power Stat CCDF Measurement” on page 142
- “Making the Spectrum (Frequency Domain) Measurement” on page 147
- “Making the Waveform (Time Domain) Measurement” on page 155

These are referred to as one-button measurements. When you press the key to select one measurement, it will become the active measurement, using settings and a display unique to that measurement. Data acquisitions will automatically begin when trigger requirements, if any, are met.

Preparing for Measurements

If you want to set the W-CDMA (3GPP) mode to a known, factory default state, press **Preset**. This will initialize the instrument by setting the mode setup and all of the measurements to the factory default parameters. The factory defaults were selected to allow many measurements to be made conveniently.

NOTE Pressing the **Preset** key does not switch instrument modes.

To preset only the parameter settings that are specific to the selected measurement, press **Meas Setup, More (1 of 2), Restore Meas Defaults**. This will reset the measurement setup parameters to the factory defaults only for the currently selected measurement.

Initial Setup

Before making a measurement, make sure the mode setup and frequency channel parameters are set to the desired settings. Refer to the sections “[Changing the Mode Setup](#)” on page 18 and “[Changing the Frequency Channel](#)” on page 23.

Measurement Selection

The **MEASURE** front-panel key accesses the menu to select one of the following measurements:

- **Channel Power** - Press this key to make channel power measurements. This is the in-channel power measurement. The channel power graph is displayed in the graph window and both the absolute channel power and mean power spectral density are shown in the text window.
- **ACPR (ACLR)** - Press this key to make adjacent channel power ratio (ACPR) measurements. This is also called Adjacent Channel Leakage power Ratio (ACLR). This is the out-of-channel measurement. The following displays are available:

Bar graph display to show a histogram of powers within the integration bandwidth

Spectrum display to show a power distribution curve, like a swept-frequency spectrum analyzer, relative to the center frequency power of the carrier signal

- **Intermod** - Press this key to make intermodulation products measurements. Three measurement modes are available as follows:

Auto - Automatically identifies one of two modes between two-tone or transmit intermodulation products.

Two-tone - Measurements are made supposing two signals to be the tone signals.

Transmit IM - Measurements are made supposing that one signal is the modulated transmitting signal and another is the tone signal.

- **Multi Carrier Power** - Press this key to make multi carrier power measurements. All power levels of two input carriers, the channels between them, and out-of-channels from them are measured by applying two input carriers of which offset should be either 5 MHz, 10 MHz, or 15 MHz. The third, fifth, and seventh order intermodulation products can be measured by setting the measurement mode.
- **Spectrum Emission Mask** - Press this key to make spectrum emission mask measurements. The measurement mask is configurable with flat and sloped lines according to the radio specifications. Spurious emission measurements can be done with some restrictions of the frequency range by selecting **Region** in **Spectrum Segment**.
- **Occupied BW** - Press this key to make occupied bandwidth measurements. The frequency bandwidth that contains 99.0% of the total power is measured as the measurement result.
- **Code Domain** - Press this key to make code domain power (CDP) measurements. The amount of power in each code channel is displayed. The following displays are available:

Power graph and metrics to show the code domain power and the summary data

Quad view for the I/Q errors in graphs for the spread rate selected, and the summary data

Quad view for the code domain power, the selected symbol power vs. symbol rate, and the selected symbol EVM polar vector graphs, and the summary data

Triad view for the code domain power and the selected symbol power graphs, and the selected demodulated bits stream text

- **Mod Accuracy (Composite EVM)** - Press this key to make modulation accuracy (composite EVM) measurements. The following displays are available:

Polar vector graph of the I/Q demodulated signal and the summary data

Polar constellation graph of the I/Q demodulated signal and the summary data

Quad view for the I/Q errors in graphs and the summary data

- **QPSK EVM** - Press this key to make QPSK error vector magnitude (EVM) measurements. The following displays are available:
 - Polar vector graph of the I/Q demodulated signal and the summary data
 - Polar constellation graph of the I/Q demodulated signal and the summary data
 - Quad view for the I/Q errors in graphs and the summary data
- **Power Stat CCDF** - Press this key to make power statistics Complementary Cumulative Distribution Function (CCDF) measurements. This is helpful to observe the time domain characteristics of a spread spectrum signal that can significantly affect the ACPR measurement results for a given UUT.
- **Spectrum (Freq Domain)** - Press this key to make frequency domain spectrum measurements. Spectrum and I/Q waveform displays are available.
- **Waveform (Time Domain)** - Press this key to make time domain waveform measurements. RF envelope and I/Q waveform displays are available.

Measurement Control

The **Meas Control** front-panel key accesses the menu to control processes that affect the running of the current measurement.

- **Restart** - Press this key to repeat the current measurement from the beginning, while retaining the current measurement settings. This is equivalent to the **Restart** front-panel key.
- **Measure** - Press this key (not to be confused with the **MEASURE** front-panel key which has a different function) to toggle the measurement state between **Single** and **Cont** (continuous). When set to **Single**, the measurement will continue until it has reached the specified number of averages set by the average counter. When set to **Cont**, the measurement will run continuously and execute averaging according to the current average mode, either repeat or exponential. The default setting is **Cont** excepting the code domain measurement and the power statistics CCDF measurement which are defaulted to **Single**.
- **Pause** - Press this key to pause the current measurement until you reactivate the measurement. Once toggled, the label of the **Pause** key changes to read **Resume**. The **Resume** key, once pressed, continues the active measurement from the point at which it was paused.

Measurement Setup

The **Meas Setup** key accesses the features that enable you to adjust parameters of the current measurement, such as span and resolution bandwidth, according to the measurement function. You will also use the **Meas Setup** menu to access the **Average**, **Limit Test**, **Advanced** and other feature menus.

The following measure setup features can be used with many or all measurements:

- **Restore Meas Defaults** - Allows you to preset only the settings that are specific to the selected measurement by pressing **Meas Setup**, **More (1 of 2)**, **Restore Meas Defaults**. This will set the measure setup parameters, for the currently selected measurement only, to the factory defaults.

Averaging

Selecting one of the averaging keys in the **Meas Setup** menu will allow you to modify the average number and averaging mode you use for the currently selected measurement. For spectrum (frequency domain) and waveform (time domain) measurements the **Average** key activates the following menu:

- **Avg Number** - Allows you to change the number of N averages to be made.
- **Avg Mode** - Allows you to toggle the averaging mode between **Exp** (exponential) and **Repeat**. This selection only effects on the averaging result after the number of N averages is reached. The N is set using the **Avg Number** key.

Normal averaging: Normal (linear) averaging is always used until the specified number of N averages is reached. When the **Measure** key under **Meas Control** is set to **Single**, data acquisition is stopped when the number of N averages is reached, thus **Avg Mode** has no effect in the single measurement mode.

Exponential averaging: When **Measure** is set to **Cont**, data acquisition will continue indefinitely. Exponential averaging is used with a weighting factor of N (the displayed count of averages stops at N). Exponential averaging weights new data more heavily than old data, which allows tracking of slow-changing signals. The weighting factor N is set using the **Avg Number** key.

Repeat averaging: When **Measure** is set to **Cont**, data acquisition will continue indefinitely. After the number of N averages is reached, all previous result data is cleared and the average count displayed is set back to 1. This is equivalent to being in **Measure**, **Single** and pressing the **Restart** key each time the single measurement finishes.

- **Avg Type** - Allows you to access the menu of the following average types only for making spectrum (frequency domain) and waveform (time domain) measurements:
 - Pwr Avg (RMS)** - Executes the true power averaging which is equivalent to taking the rms of the voltage. This is the most accurate type.
 - Log-Pwr Avg (Video)** - Simulates the traditional spectrum analyzer type of averaging by calculating the log of the power.
 - Voltage Avg** - Executes the voltage averaging.
 - Maximum** - Executes the maximum voltage averaging by capturing peak data.
 - Minimum** - Executes the minimum voltage averaging.

Selecting a Trigger Source

Changing the selection in the **Trig Source** menu alters the trigger source for the selected measurement only. Not all of the selections are always available for all measurements. Also, some W-CDMA (3GPP) measurements do not require a trigger. Choose one of the following trigger sources:

NOTE

The **RF Burst**, **Video (IF Envlp)**, **Ext Front** and **Ext Rear** keys found under the **Trigger** menu enable you to change the default settings of the delay, level and slope for each of these trigger sources.

- **Free Run (Immediate)** - A trigger occurs at the time the data is requested, completely asynchronous with the RF or IF signal.
- **Video (IF Envlp)** - An internal IF envelope trigger that occurs at the absolute threshold level of the IF signal level.
- **RF Burst (Wideband)** - An internal wideband RF burst trigger that has the automatic level control for burst signals. It triggers at the level that is set relative to the peak RF signal (12 MHz bandwidth) input level.
- **Ext Front** - Activates the front-panel external trigger input (**EXT TRIGGER INPUT**) port. The external signal must be between -5.00 and $+5.00$ V with 1 or 10 mV resolution.
- **Ext Rear** - Activates the rear-panel external trigger input (**TRIGGER IN**) port. The external signal must be between -5.00 and $+5.00$ V with 1 or 10 mV resolution.
- **Frame** - Uses the internal frame clock to generate a trigger signal. The clock parameters are controlled under the **Mode Setup** key or the measurement firmware, but not both. See the specific measurement for details.

- **Line** - Sets the trigger to the internal line mode. Sweep triggers occur at intervals synchronous to the line frequency. This trigger source is available for spectrum (frequency domain) and waveform (time domain) measurements.

Using the Trigger Outputs

The rear panel **TRIGGER 1 OUT** and **TRIGGER 2 OUT** connectors are coupled to the selected trigger source. These trigger outputs are always on at the rising edge with a pulse width of at least 1 μ s.

Making the Channel Power Measurement

Purpose

Channel power measurement is a common test used in the wireless industry to measure the total transmitted power of a radio within a defined frequency channel. This procedure measures the total power within the defined channel for W-CDMA (3GPP). This measurement can be used to design, characterize, evaluate, and verify transmitters and components or devices for base stations and mobile stations.

Measurement Method

The channel power measurement reports the total power within the channel bandwidth, 3.840 MHz for the 3GPP mode. The transmitter tester acquires a number of points representing the input signal in the time domain. It transforms this information into the frequency domain using FFT and then calculates the channel power. The effective resolution bandwidth of the frequency domain trace is proportional to the number of points acquired for FFT. The fastest FFT process is achieved using a number of acquired points that is a power of 2 (for example: 64, 128, 512).

Since the measurement is optimized for speed and accuracy, you are permitted to change only the number of acquired data points in powers of 2, not the actual resolution bandwidth which is shown in gray. However, if absolute sweep time is required, sweep time can be changed to the user's specified time at the expense of reduced speed. At no time will both sweep time and data points be set to manual because of conflicting parameter settings. This flexibility is available through the **Advanced** menu of the channel power measurement.

To improve repeatability, you can increase either the number of averages or the number of data points with longer time record length. The channel power graph is shown in the graph window and the absolute channel power in dBm and the mean power spectral density in dBm/Hz are shown in the text window.

Making the Measurement

NOTE

The factory default settings provide a good starting point. For special requirements, you may need to change some of the settings. Press **Meas Setup, More (1 of 2), Restore Meas Defaults** at any time to return all parameters for the current measurement to their default settings.

Select the desired center frequency as described in “[Changing the Frequency Channel](#)” on page 23.

Press **MEASURE, Channel Power** to immediately make a channel power measurement.

To change any of the measurement parameters from the factory default values, refer to “[Changing the Measurement Setup](#)” on page 63 for this measurement.

Results

The next figure shows an example result of Channel Power measurements. The channel power graph is shown in the graph window. The absolute channel power and its mean power spectral density are shown in the text window.

Figure 3-1

Channel Power Measurement

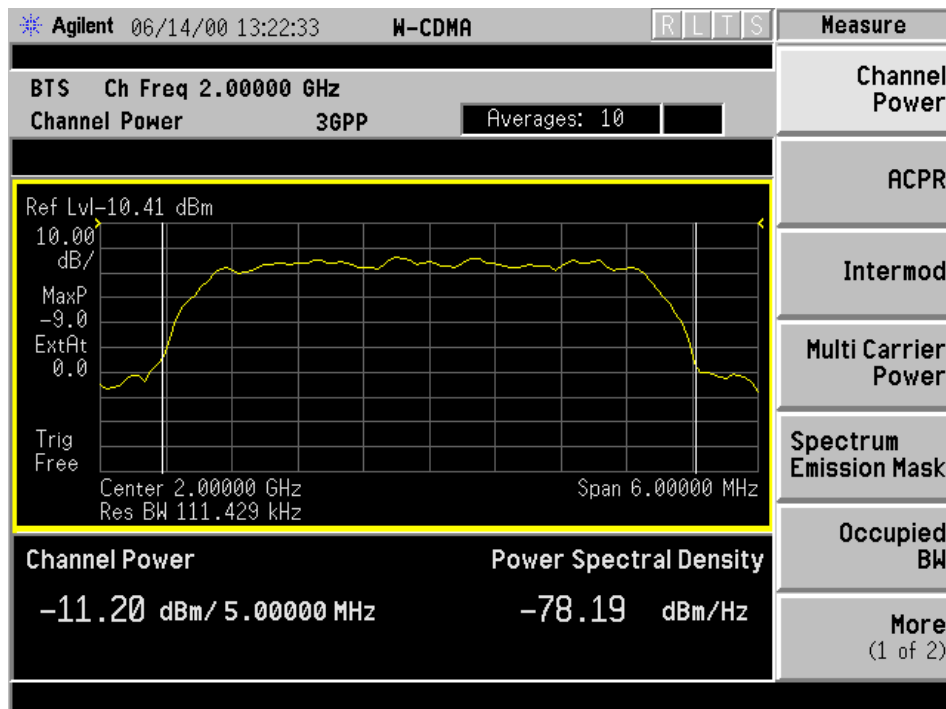

Changing the Measurement Setup

The next table shows the factory default settings for channel power measurements.

Table 3-1 Channel Power Measurement Defaults

Measurement Parameter	Factory Default Condition
Meas Setup:	
Avg Number	10, On
Avg Mode	Repeat
Integ BW ^a	5.00000 MHz
Chan Power Span ^a	6.00000 MHz
Advanced	
Sweep Time	17.07 μ s, Auto
Data Points	512, Auto
Trig Source	Free Run (Immediate)

a. The Integ BW setting proportionally changes the Chan Power Span setting up to 10 MHz.

NOTE

Parameters under the **Advanced** key seldom need to be changed. Any changes from the factory default values may result in invalid measurement data.

Make sure the **Channel Power** measurement is selected under the **MEASURE** menu. The **Meas Setup** key accesses the menu which allows you to modify the average number and average mode for this measurement as described in “[Measurement Setup](#)” on page 58.

In addition, the following parameters can be changed according to your measurement requirement:

- **Integ BW** - Allows you to specify the integration bandwidth in which the power is measured. The range is 1.000 kHz to 10.0000 MHz with 1 Hz resolution. Since **Integ BW** is coupled to **Chan Power Span** in the factory default condition, if you change the integration bandwidth setting, the channel power span setting changes by a proportional amount until a limit value is reached.

- **Chan Power Span** - Allows you to set the frequency span for the channel power measurement. The range is 1.000 kHz to 10.0000 MHz with 1 Hz resolution. This span is used for the current integration bandwidth setting. Since **Chan Power Span** is coupled to **Integ BW** in the factory default condition, if you change the integration bandwidth setting, the channel power span setting changes by a proportional amount, 1.2 times the integration bandwidth, until a limit value is reached. However, the channel power span can be individually set.
- **Advanced** - Allows you to access the following menu to modify the channel power measurement parameters:

Sweep Time - Allows you to toggle the sweep time control between **Auto** and **Man** (manual), and also to manually change the sweep time if set to **Man**. The range is 1.000 μ s to 50.00 ms with 1 μ s resolution. If set to **Auto**, the sweep time derived from the data points setting is shown on this key label regardless of the manual entry range.

Data Points - Allows you to toggle the data point control between **Auto** and **Man** (manual), and also to manually change the data points if set to **Man**. The range is 64 to 65536 with the acceptable entry in powers of 2 (for example: 64, 128, 512). If set to **Auto**, the data point derived from the sweep time setting is shown on this key label regardless of the manual entry range.

Res BW - Shows information on the resolution bandwidth derived from the sweep time.

Trig Source - Allows you to change the trigger source from free run (immediate) to the external input signal supplied to either **Ext Front** or **Ext Rear** port.

Changing the Display

The **AMPLITUDE Y Scale** key accesses the menu to set the desired vertical scale and associated parameters.

- **Scale/Div** - Allows you to enter a numeric value to change the vertical display sensitivity. The range is 0.10 to 20.00 dB with 0.01 dB resolution. The default setting is 10.00 dB, however, since **Scale Coupling** is defaulted to **On**, this value is automatically determined by the measurement result.
- **Ref Value** - Allows you to enter a numeric value to change the absolute power value as the display reference. The range is -250.00 to 250.00 dBm with 0.01 dB resolution. The default setting is 10.00 dBm, however, since **Scale Coupling** is defaulted to **On**, this value is automatically determined by the measurement result.
- **Ref Position** - Allows you to set the display reference position to either **Top**, **Ctr** (center), or **Bot** (bottom). The default setting is **Top**.
- **Scale Coupling** - Allows you to toggle the scale coupling function between **On** and **Off**. The default setting is **On**. Upon pressing the **Restart** front-panel key or **Restart** softkey under the **Meas Control** menu, this function automatically determines the scale per division and reference values by the measurement results.

Troubleshooting Hints

If an external attenuator is used, be sure to include its attenuation in the measurement of the channel power. Use the **Ext Atten** key.

The channel power measurement can reveal degraded or defective parts in the transmitter section of the UUT. The following examples are those areas to be checked further.

- Some faults in the DC power supply control of the transmitter power amplifier, RF power controller of the pre-power amplifier stage, and/or I/Q control of the baseband stage.
- Some degradation in the gain and output power level of the amplifier due to the degraded gain control and/or increased distortion.
- Some degradation of the amplifier linearity and other performance characteristics.

Power amplifiers are one of the final stage elements of a base or mobile transmitter and are a critical part of meeting the important power and spectral efficiency specifications. Since the channel power measurement measures the spectral response of the amplifier to a complex wideband signal, it is a key measurement linking amplifier linearity and other performance characteristics to the stringent system specifications.

Making the Adjacent Channel Power Ratio (ACPR) Measurement

Purpose

Adjacent Channel Power Ratio (ACPR), as it applies to W-CDMA (3GPP), is the power contained in a specified frequency channel bandwidth relative to the total carrier power. It may also be expressed as a ratio of power spectral densities between the carrier and the specified offset frequency band. This is also called Adjacent Channel Leakage power Ratio (ACLR).

As a composite measurement of out-of-channel emissions, ACPR combines both in-band and out-of-band specifications to provide useful figures-of-merit for spectral regrowth and emissions produced by components and circuit blocks without the rigor of performing a full spectrum emissions mask measurement.

Measurement Method

The ACPR measurement measures up to five pairs of offset channels and relates them to the carrier power. An integration bandwidth (IBW) method is used to measure the carrier channel power and offset powers.

The IBW method performs a time domain data acquisition and applies FFT to get a frequency domain trace. In this process, the channel integration bandwidth is analyzed using the automatically defined resolution bandwidth (RBW), which is much narrower than the channel bandwidth. The measurement computes an average power of the channel over a specified number of data acquisitions, automatically compensating for resolution bandwidth and noise bandwidth.

This measurement requires the user to specify measurement bandwidths of the carrier channel and each of the offset frequency pairs up to 5. Each pair may be defined with unique measurement bandwidths. The results are displayed both as relative power in dBc, and as absolute power in dBm.

Making the Measurement

NOTE

The factory default settings provide a good starting point. For special requirements, you may need to change some of the settings. Press **Meas Setup, More (1 of 2), Restore Meas Defaults** at any time to return all parameters for the current measurement to their default settings.

Select the desired center frequency as described in [“Changing the Frequency Channel” on page 23](#).

Press **MEASURE, ACPR (ACLR)** to immediately make an adjacent channel power ratio (ACPR) measurement.

To change any of the measurement parameters from the factory default values, refer to [“Changing the Measurement Setup” on page 69](#).

Results

The next figure shows an example result of ACPR-FFT Bar Graph (Total Pwr Ref) measurements in the graph window. The absolute and relative power levels on both sides of the carrier frequency are displayed in the text window.

Figure 3-2

ACPR Measurement - FFT Bar Graph View

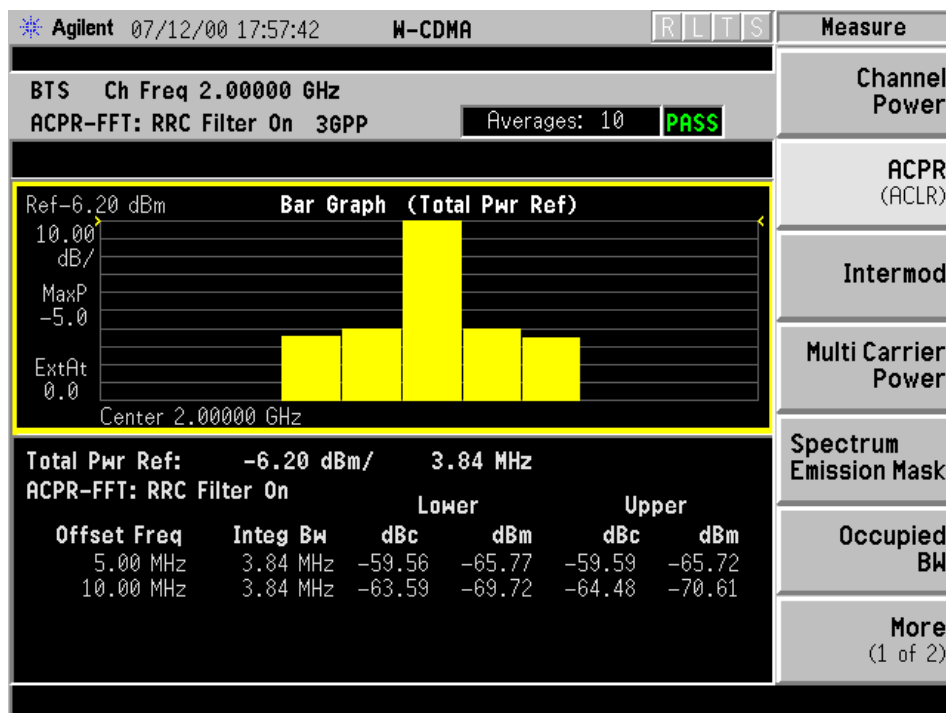

Changing the Measurement Setup

The next table shows the factory default settings for adjacent channel power ratio measurements.

Table 3-2 Adjacent Channel Power Ratio Measurement Defaults

Measurement Parameter	Factory Default Condition
View/Trace	Bar Graph (Total Pwr Ref)
Meas Setup:	
Avg Number	10, On
Avg Mode	Repeat
Chan Integ BW:	3.84000 MHz
Ofs & Limits:	
Offset	A
Offset Freq:	
A	5.00000 MHz, On
B	10.0000 MHz, On
C	15.0000 MHz, Off
D	20.0000 MHz, Off
E	25.0000 MHz, Off
Ref BW:	
A to E	3.84000 MHz
Abs Limit:	
A to E	50.00 dBm
Fail:	
A to E	Relative
Rel Lim (Car):	
A to E	0.00 dBc
Rel Lim (PSD):	
A to E	0.00 dB
Meas Type	Total Pwr Ref
Sweep Type	FFT
Advanced	
Swp Acq Time	625.0 μ s (if Sweep Type is Swp)
RRC Filter	On
Alpha	0.220

Make sure the **ACPR** measurement is selected under the **MEASURE** menu. The **Meas Setup** key accesses the menu which allows you to modify the average number and average mode for this measurement as described in “[Measurement Setup](#)” on page 58.

In addition, the following parameters can be changed according to your measurement requirement:

- **Chan Integ BW** - Allows you to specify the channel integration bandwidth in which the carrier power is measured. The range is 300.0 Hz to 20.0000 MHz with 1 Hz resolution.
- **Ofs & Limits** - Allows you to access the menu to change the following parameters for offset frequency settings and pass/fail tests:

Offset - Allows you to access the memory selection menu from **A** to **E** to store 5 sets of values for **Offset Freq**, **Ref BW**, **Abs Limit** and so forth. Only one selection at a time (A, B, C, D, or E) is shown on this key label.

Offset Freq - Allows you to enter an offset frequency value, and to toggle the offset frequency function between **On** and **Off**, according to each offset key selected. The range is 0.0 Hz to 100.000 MHz. While this key is activated, enter an offset frequency value from the numeric keypad by terminating with one of the frequency unit keys shown. One offset frequency value selected from the **Offset** menu is shown on this key label.

Ref BW - Allows you to enter a reference bandwidth ranging from 300.0 Hz to 20.0000 MHz with 1 Hz resolution. When this parameter is changed, the integration bandwidth **Integ BW** in the summary data window changes to that value.

Abs Limit - Allows you to enter an absolute limit value ranging from -200.00 to +50.00 dBm with 0.01 dB resolution.

Fail - Allows you to access the following menu to select one of the logic keys for fail conditions between the measurement results and the test limits:

AND - Fail is shown if one of the relative ACPR measurement results is larger than the limit for **Rel Lim (Car)** or **Rel Lim (PSD)** AND one of the absolute ACPR measurement results is larger than the limit for **Abs Limit**.

OR - Fail is shown if one of the relative ACPR measurement results is larger than the limit for **Rel Lim (Car)** or **Rel Lim (PSD)** OR one of the absolute ACPR measurement results is larger than the limit for **Abs Limit**.

Absolute - Fail is shown if one of the absolute ACPR measurement results is larger than the limit for **Abs Limit**.

Relative - Fail is shown if one of the relative ACPR measurement results is larger than the limit for **Rel Lim (Car)** or **Rel Lim (PSD)**.

Rel Lim (Car) - Allows you to enter a relative limit value of the carrier level ranging from -200.00 to $+50.00$ dBc with 0.01 dB resolution.

Rel Lim (PSD) - Allows you to enter a relative limit value of the power spectral density level ranging from -200.00 to $+50.00$ dB with 0.01 dB resolution.

- **Meas Type** - Allows you to access the menu to select one of the measurement reference types.

Total Pwr Ref - Sets the reference to the total carrier power and the measured data is shown in dBc and dBm.

PSD Ref - Sets the reference to the mean power spectral density of the carrier and the measured data is shown in dB and dBm/Hz.

- **Sweep Type** - Allows you to toggle the sweep function between **FFT** and **Swp** (swept). If set to **Swp**, the measurement is made by the swept spectrum method like the traditional swept frequency spectrum analysis to have better correlation to the input signal with a high crest factor (peak/average ratio). However, it may take a longer time. Also, only the **Spectrum** view is available.
- **Swp RBW** - Allows you to enter the sweep resolution bandwidth, and to toggle this function between **Auto** and **Man** (manual), when **Sweep Type** is set to **Swp**. If set to **Auto**, this is automatically set according to the sweep span derived from **Offset Freq** and **Ref BW**. If set to **Man**, this is manually changed. The range is 1.000 kHz to 1.00000 MHz with 1 Hz resolution. The default setting is 41.667 kHz and **Auto**.
- **Swp Det** - Allows you to toggle the sweep detection type between **Avg** (average) and **Peak**, when **Sweep Type** is set to **Swp**. The default selection is **Peak**.
- **Advanced** - Allows you to access the menu to set the following parameter:

Swp Acq Time - Allows you to set the data acquisition time when **Sweep Type** is set to **Swp**. The range is 500.0 μ s to 10.00 ms with 1 μ s resolution.

RRC Filter - Allows you to toggle the root-raised cosine filter function between **On** and **Off**. The default setting is **On**.

Alpha - Allows you to change the alpha value of the RRC filter. The range is 0.010 to 0.500 with 0.001 resolution.

Changing the View

The **View/Trace** key accesses the menu to select the desired view of the measurement result as follows when **Sweep Type** is set to **FFT**. When **Sweep Type** is set to **Swp**, the **Bar Graph** key is not available only to show the spectrum display.

- **Bar Graph** - In the factory default condition, 5 of the total integration power levels, centered at the carrier frequency and ± 5.0 MHz and ± 10.0 MHz offset frequencies, are shown in the graph window. The corresponding measured data is shown in the text window as shown in [Figure 3-2 on page 68](#). Depending on the **Meas Type** setting, one of the two following displays is obtained:

Bar Graph (Total Pwr Ref) - A histogram of powers referenced to the total carrier power

Bar Graph (PSD Ref) - A histogram of powers referenced to the mean power spectral density of the carrier in dBm/Hz

- **Spectrum** - In the factory default condition, the frequency spectrum with the FFT sweep type is displayed with the bandwidth marker lines in the graph window. The corresponding measured data in the text window is the total integration power levels within the defined bandwidth as shown in the figure below.

Figure 3-3 ACPR Measurement - FFT Spectrum (Total Pwr Ref) View

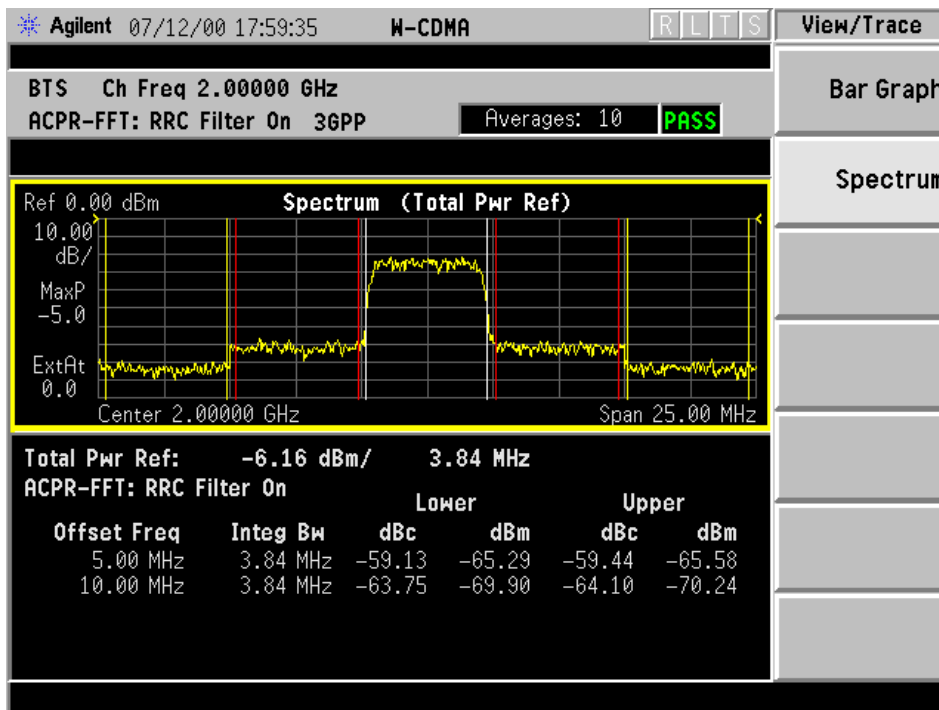

Depending on the **Meas Type** setting, one of the two following displays is obtained with either **FFT** or **Swp** mode:

Spectrum (Total Pwr Ref) - A spectrum display referenced to the total carrier power

Spectrum (PSD Ref) - A spectrum display referenced to the mean power spectral density of the carrier in dBm/Hz

Figure 3-4 ACPR Measurement - Swp Spectrum (Total Pwr Ref) View

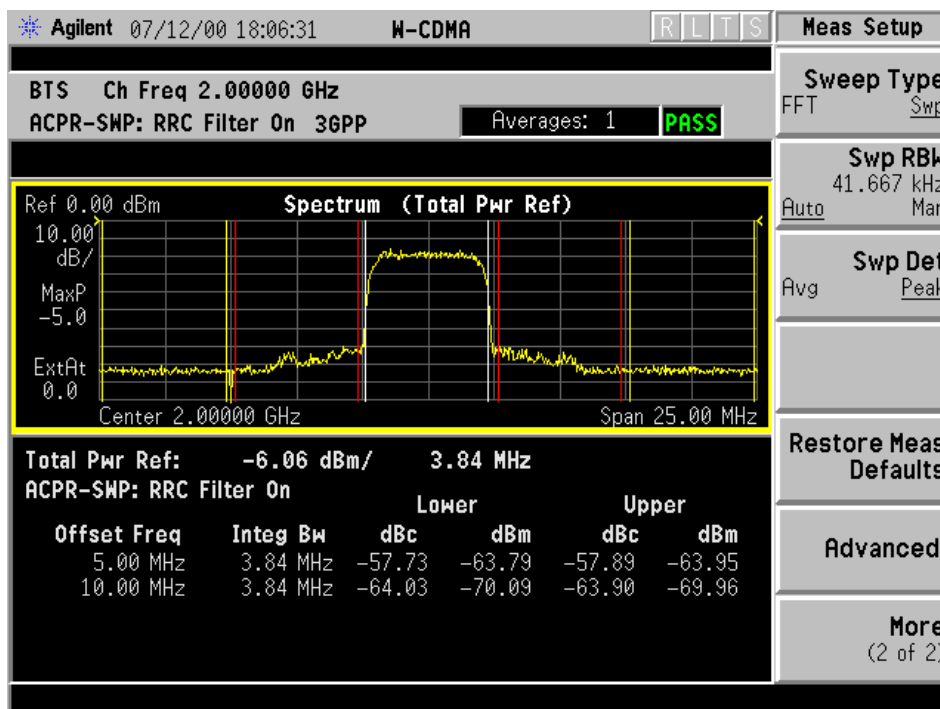

NOTE If **Sweep Type** is set to **FFT**, the spectrum graph does not show the actual power level measured at each of the offsets. Select **Swp** for the more accurate spectrum graph.

While in this view, you can change the vertical scale by pressing the **AMPLITUDE Y Scale** key. You can also activate or deactivate the reference bandwidth markers by pressing the **Display** key.

Changing the Display

If **View/Trace** is set to **Spectrum**, the **AMPLITUDE Y Scale** key accesses the menu to set the desired measurement scale and associated parameters:

- **Scale/Div** - Allows you to enter a numeric value to change the vertical display sensitivity. The range is 0.10 to 20.00 dB with 0.01 dB resolution. The default setting is 10.00 dB, however, since the **Scale Coupling** is defaulted to **On**, this value is automatically determined by the measurement result.
- **Ref Value** - Allows you to set the absolute power reference value ranging from -250.00 to 250.00 dBm with 0.01 dB resolution. The default setting is 10.00 dBm, however, since the **Scale Coupling** is defaulted to **On**, this value is automatically determined by the measurement result.
- **Ref Position** - Allows you to set the reference position to either **Top**, **Ctr** (center), or **Bot** (bottom). The default setting is **Top**.
- **Scale Coupling** - Allows you to toggle the scale coupling function between **On** and **Off**. The default setting is **On**. Upon pressing the **Restart** front-panel key or **Restart** softkey under the **Meas Control** menu, this function automatically determines the scale per division and reference values by the measurement results.

If **View/Trace** is set to **Spectrum**, the **Display** key also accesses the menu to control the markers as follows:

- **Ref BW Markers** - Allows you to toggle the reference bandwidth markers function between **On** and **Off**. If set to **On**, the vertical line markers with the reference bandwidth are shown on the measurement result display.

Troubleshooting Hints

If an external attenuator is used, be sure to include its attenuation in the ACPR measurement. Use the **Ext Atten** key.

This adjacent channel power ratio measurement can reveal degraded or defective parts in the transmitter section of the UUT. The following examples are those areas to be checked further.

- Some faults in the DC power supply control of the transmitter power amplifier, RF power controller of the pre-power amplifier stage, or I/Q control of the baseband stage
- Some degradation in the gain and output power level of the amplifier due to the degraded gain control and/or increased distortion
- Some degradation of the amplifier linearity and other performance characteristics

Power amplifiers are one of the final stage elements of a base or mobile transmitter and are a critical part of meeting the important power and spectral efficiency specifications. Since ACPR measures the spectral response of the amplifier to a complex wideband signal, it is a key measurement linking amplifier linearity and other performance characteristics to the stringent system specifications.

Making the Intermodulation Measurement

Purpose

Intermodulation products are generated by nonlinear components or devices in an equipment with having two signals, one desired and another undesired. Transmit intermodulation is a measure of a transmitter to inhibit the generation of intermodulation products in the presence of the modulated signal and the tone signal.

Measurement Method

The intermodulation measurement measures the third order and fifth order intermodulation products caused by two signals. These intermodulation products are generated by the nonlinear devices or circuits in a transmitter. The measured results are evaluated in the relative ratio to the carrier power. The 3GPP defines the transmit intermodulation as a measure of transmitter capability. There are two types of intermodulation as follows:

- Two-tone - Measurements are made supposing two signals to be the tone signals.
- Transmit IM - Measurements are made supposing that one signal is the modulated transmitting signal and another is the tone signal.

This measurement automatically identifies either two-tone intermodulation mode or transmit intermodulation mode at the start of measurements. The fundamental signals, lower and upper, are automatically searched every sweep to calculate the proper results. When a measurement starts, the highest two peaks at frequencies f_0 and f_1 are searched within a given span. Based on these frequencies, the possible frequencies for third and fifth order intermodulation products are calculated. The power bandwidth is checked to determine if the mode is two-tone or transmit intermodulation. For avoiding erroneous measurement results, it is recommended that either of the upper or lower signal is set to the center frequency. This will ensure to utilize the internal attenuator in the automatic input range control mode to make appropriate measurements.

The results are displayed both as relative power in dBc and as absolute power in dBm. For transmit intermodulation products, the result is also shown as the power spectral density in dBm/MHz.

Making the Measurement

NOTE

The factory default settings provide a good starting point. For special requirements, you may need to change some of the settings. Press **Meas Setup, More (1 of 2), Restore Meas Defaults** at any time to return all parameters for the current measurement to their default settings.

Select the desired center frequency as described in [“Changing the Frequency Channel” on page 23](#).

Press **MEASURE, Intermod (Intermodulation)** to immediately make an intermodulation measurement.

To change any of the measurement parameters from the factory default values, refer to [“Changing the Measurement Setup” on page 78](#).

Results

The next figure shows an example result of Intermodulation measurements in the graph window. The absolute power levels, relative power levels, and power spectral density levels on both sides of the reference signal are displayed in the text window.

Figure 3-5

Intermodulation Measurement

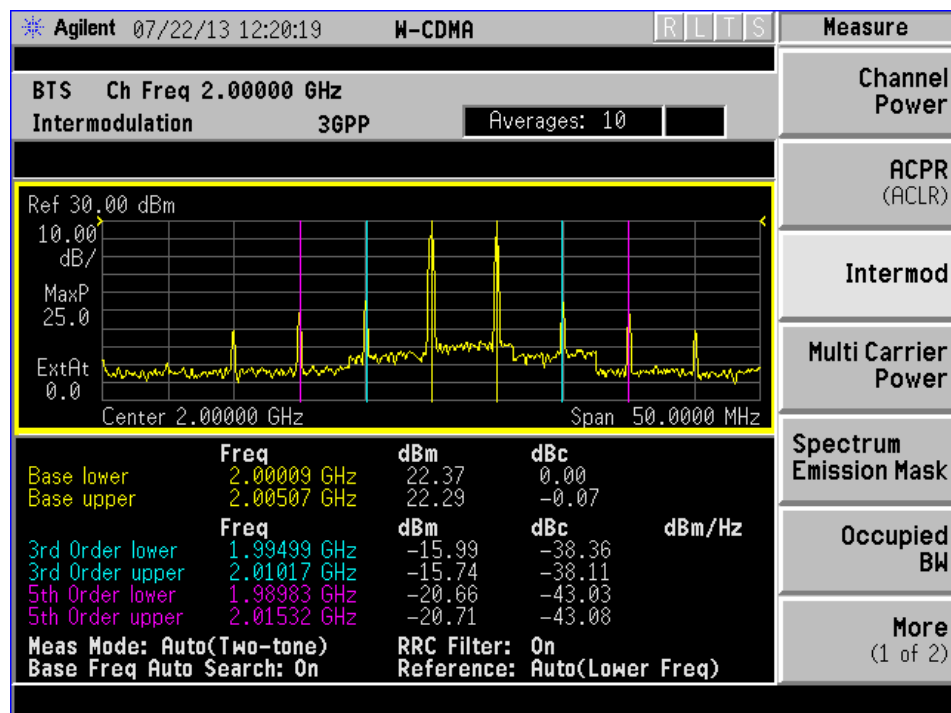

Changing the Measurement Setup

The next table shows the factory default settings for intermodulation measurements.

Table 3-3 Intermodulation Measurement Defaults

Measurement Parameter	Factory Default Condition
Display: IM Prod Lines	On
Meas Setup:	
Avg Number	10, On
Avg Mode	Repeat
Meas Mode	Auto
Reference	Auto
Span	50.0000 MHz
Res BW	140.000 kHz, Auto
Base Freq Auto Search	On
Base Freq	(not available due to Base Freq Auto Search is set to On)
Advanced	
RRC Filter	On
Alpha	0.220
Integ BW	3.84000 MHz

Make sure the **Intermod** measurement is selected under the **MEASURE** menu. The **Meas Setup** key accesses the menu which allows you to modify the average number and average mode for this measurement as described in [“Measurement Setup” on page 58](#).

In addition, the following parameters can be changed according to your measurement requirement:

- **Meas Mode** - Allows you to specify one of the following measurement modes:

Auto - Automatically identifies the intermodulation caused by either the two-tone or transmit intermodulation signals.

Two-tone - Measures the two-tone intermodulation products.

Transmit IM - Measures the transmit intermodulation products.

- **Reference** - Allows you to specify one of the following references:
 - Auto** - Automatically sets the highest level signal in two base frequency signals as measurement reference.
 - Lower Freq** - Sets the base lower frequency signal as measurement reference.
 - Upper Freq** - Sets the base upper frequency signal as measurement reference.
 - Average** - Sets the average frequency signals, (base lower frequency signal + base upper frequency signal)/2, as measurement reference.
- **Span** - Allows you to specify the frequency span in which intermodulation products are measured. The range is 100.000 kHz to 100.000 MHz with 1 Hz resolution.
- **Res BW** - Allows you to specify the resolution bandwidth in which intermodulation products are measured, and to toggle this function between **Auto** and **Man**. If set to **Auto**, the resolution bandwidth is automatically set according to the frequency span. The range is 100.0 Hz to 300.000 kHz with 1 Hz resolution.
- **Res BW** - Allows you to specify the resolution bandwidth in which intermodulation products are measured, and to toggle this function between **Auto** and **Man**. If set to **Auto**, the resolution bandwidth is automatically set according to the frequency span. The range is 100.0 Hz to 300.000 kHz with 1 Hz resolution.
- **Base Freq Auto Search** - Allows you to toggle the base frequency auto search function between **On** and **Off**. If set to **On**, the base frequency is automatically searched for.
- **Base Freq** - Allows you to specify the base frequency values with the followings items if **Base Freq Auto Search** is set to **Off** (otherwise this key is not available):
 - Lower Freq (f0)** - Accepts a frequency value for the base lower frequency (f0).
 - Upper Freq (f1)** - Accepts a frequency value for the base upper frequency (f1).
 - Delta (f1 – f0)** - Automatically shows the difference between the base lower and base upper frequencies.

- **Advanced** - Allows you to access the menu to set the following items:
 - RRC Filter** - Toggles to set the root-raised cosine filter between **On** and **Off**.
 - Alpha** - Allows you to specify the alpha value of the root-raised cosine filter. The range is 0.01 to 0.50.
 - Integ BW** - Allows you to specify the integration bandwidth ranging from 100.0 kHz to 5.000 MHz.

Changing the View

The **View/Trace** key is not available for this measurement.

Changing the Display

When the spectrum graph window is selected, the **AMPLITUDE Y Scale** key accesses the menu to set the desired measurement scale and associated parameters:

- **Scale/Div** - Allows you to enter a numeric value to change the vertical display sensitivity. The range is 0.10 to 20.00 dB with 0.01 dB resolution. The default setting is 10.00 dB, however, since the **Scale Coupling** is defaulted to **On**, this value is automatically determined by the measurement result.
- **Ref Value** - Allows you to set the absolute power reference value ranging from -250.00 to 250.00 dBm with 0.01 dB resolution. The default setting is 10.00 dBm, however, since the **Scale Coupling** is defaulted to **On**, this value is automatically determined by the measurement result.
- **Ref Position** - Allows you to set the reference position to either **Top**, **Ctr** (center), or **Bot** (bottom). The default setting is **Top**.
- **Scale Coupling** - Allows you to toggle the scale coupling function between **On** and **Off**. The default setting is **On**. Upon pressing the **Restart** front-panel key or **Restart** softkey under the **Meas Control** menu, this function automatically determines the scale per division and reference values by the measurement results.

The **Display** key also accesses the menu to control the markers on the display as follows:

- **IM Prod Lines** - Allows you to toggle the intermodulation product lines display function between **On** and **Off**. If set to **On**, two pairs of the dual vertical lines with the integration bandwidth are shown on the third- and fifth-order intermodulation products display.

Troubleshooting Hints

This intermodulation measurement can reveal degraded or defective parts in the transmitter section of the UUT. The following examples are those areas to be checked further.

- Some faults in the DC power supply control of the transmitter power amplifier, RF power controller of the pre-power amplifier stage, or I/Q control of the baseband stage
- Some degradation in the gain and output power level of the amplifier due to the degraded gain control and/or increased distortion
- Some degradation of the amplifier linearity and other performance characteristics

Power amplifiers are one of the final stage elements of a base or mobile transmitter and are a critical part of meeting the important power and spectral efficiency specifications. Since intermodulation measures the spectral response of the amplifier to a complex wideband signal, it is a key measurement linking amplifier linearity and other performance characteristics to the stringent system specifications.

Making the Multi Carrier Power Measurement

Purpose

This measurement is for adjusting multi carrier power amplifiers to transmit well balanced multiple carriers. In this measurement, two carrier inputs are required to make measurements of the in-channels and out-of-channels powers. Four carrier inputs can be measured even if the reference channel selection is limited to two out of four carriers. If a power amplifier accepts multiple carriers, the intermodulation products caused by these carriers will act to decrease the performance of the amplifier.

Measurement Method

Basically, this measurement method is very similar to a combination of those for ACPR measurements, specifically upon making measurements with the measuring mode of **All Channels**, and intermodulation products measurements, specifically upon making measurements with the measuring mode of **3rd IM Only** or **3rd/5th/7th IM**.

Given that a signal is the center carrier and another signal is the second carrier, the second carrier frequency needs to be offset by a multiple of 5 MHz from the center carrier frequency. This multiplier ranges from ± 1 to ± 3 , resulting in the offset frequencies at -15 MHz, -10 MHz, -5 MHz, $+5$ MHz, $+10$ MHz, and $+15$ MHz.

If **Meas Mode** is set to **All Channels**, the center and second carrier levels along with the power levels in the lower and upper offset channels are listed in the text window. The lower offset channels are referenced to the lower frequency carrier channel, and the upper offset channels are referenced to the upper frequency carrier channel. Depending on the selection of the second carrier offsets, one or two -5 MHz offset channels can be displayed between the center and second carrier channels.

If **2nd Carrier Offset** is set to either -15 MHz or $+15$ MHz, the power levels at -5 , 5 , 10 , and 15 MHz offset channels from the lower and upper frequency carrier channels are measured respectively. The -5 MHz offset channel from the lower frequency carrier is displayed next right to the lower frequency carrier channel, and the -5 MHz offset channel from the upper frequency carrier is displayed next left to the upper frequency carrier channel.

If **2nd Carrier Offset** is set to either -10 MHz or $+10$ MHz, the power levels at -5 , 5 , 10 , and 15 MHz offset channels from the lower and upper frequency carrier channels are measured.

If **2nd Carrier Offset** is set to either -5 MHz or $+5$ MHz, the power levels at 5 and 10 MHz offset channels from the lower and upper frequency carrier channels are measured.

If **Meas Mode** is set to **3rd IM Only** or **3rd/5th/7th IM**, the intermodulation product levels caused by two carriers are measured in the offset channels corresponding to the selection of the second carrier offset.

For getting the relative measurement results in addition to the absolute power levels, the reference channel power can be set to one of the following: lower frequency carrier, upper frequency carrier, average of two carriers, or to the automatic selection. This automatic selection is to identify the highest power level in the two carrier powers as the reference channel power. Auto (Lower) is shown if the lower frequency carrier power is equal to or larger than that of the upper frequency carrier, and Auto (Upper) is shown if the upper frequency carrier power is larger than that of the lower frequency carrier.

Making the Measurement

NOTE

The factory default settings provide a good starting point. For special requirements, you may need to change some of the settings. Press **Meas Setup, More (1 of 2), Restore Meas Defaults** at any time to return all parameters for the current measurement to their default settings.

Select the desired center frequency as described in [“Changing the Frequency Channel” on page 23](#).

Press **MEASURE, Multi Carrier Power** to immediately make a multi carrier power measurement.

To change any of the measurement parameters from the factory default values, refer to [“Changing the Measurement Setup” on page 85](#).

Results

The next figure shows an example result of Bar Graph (Total Pwr Ref) for the multi carrier power measurements in the graph window. The relative and absolute power levels for the center and second carriers, the lower and upper offset channels, and other parameters are shown in the text window.

Figure 3-6 Multi Carrier Power Measurement - 2nd Carrier Offset +5 MHz

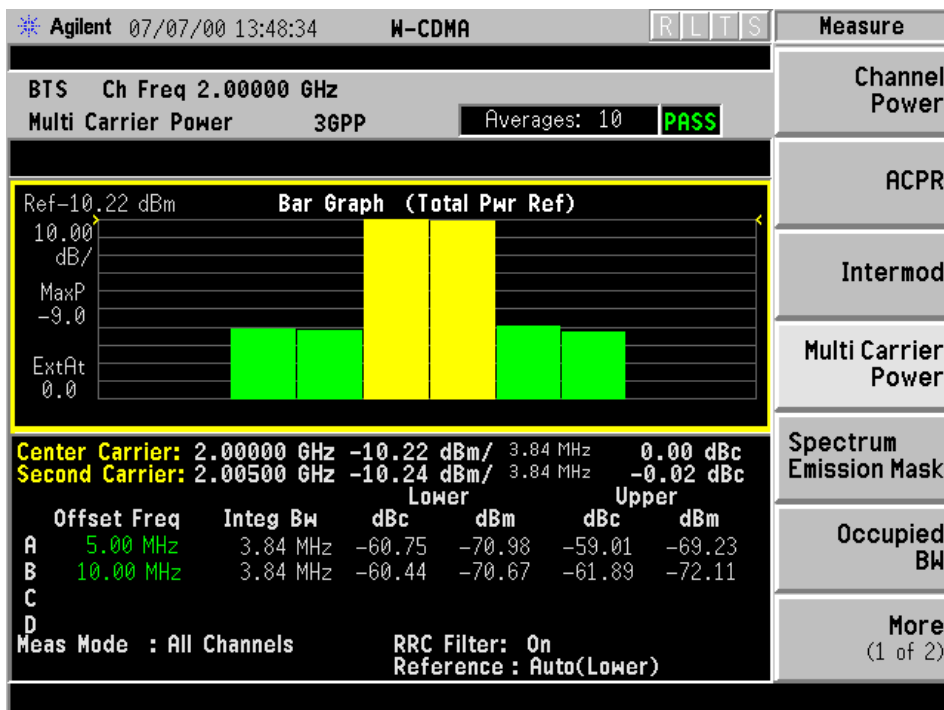

Changing the Measurement Setup

The next table shows the factory default settings for multi carrier power measurements.

Table 3-4 Multi Carrier Power Measurement Defaults

Measurement Parameter	Factory Default Condition
Meas Setup:	
Avg Number	10, On
Avg Mode	Repeat
2nd Car Ofs	+5 MHz
Ref Chan	Auto, Auto
Meas Mode	All Channels
Ofs & Limits:	
Offset	A
Abs Limit	50.00 dBm
Fail	Relative
Rel Lim (Car)	0.00 dBc
Advanced	
RRC Filter	On
Alpha	0.220

NOTE Parameters under the **Advanced** key seldom need to be changed. Any changes from the factory default values may result in invalid measurement data.

Make sure the **Multi Carrier Power** measurement is selected under the **MEASURE** menu. The **Meas Setup** key accesses the menu which allows you to modify the average number and average mode for this measurement as described in [“Measurement Setup” on page 58](#).

In addition, the following parameters can be changed according to your measurement requirement:

- **2nd Car Ofs** - Allows you to access the following menu to select one of the offset frequency values for the second carrier to be measured:
 - +15MHz** - Sets the second carrier offset frequency to +15.0 MHz from the center carrier frequency.
 - +10MHz** - Sets the 2nd carrier offset frequency to +10.0 MHz from the center carrier frequency.

+5MHz - Sets the 2nd carrier offset frequency to +5.0 MHz from the center carrier frequency.

-5MHz - Sets the 2nd carrier offset frequency to -5.0 MHz from the center carrier frequency.

-10MHz - Sets the 2nd carrier offset frequency to -10.0 MHz from the center carrier frequency.

-15MHz - Sets the 2nd carrier offset frequency to -15.0 MHz from the center carrier frequency.

- **Ref Chan** - Allows you to access the following menu to select one of the reference channel levels:

Auto - Sets the highest carrier power level in two carriers to the reference channel level to make relative power measurements. Auto (Lower) is shown in the text window if the lower frequency carrier power is equal to or larger than the upper frequency carrier power, and Auto (Upper) is shown in the case of the upper frequency carrier power is larger than the lower frequency carrier power.

Lower - Sets the lower frequency carrier power to the reference channel level to make relative power measurements.

Upper - Sets the upper frequency carrier power to the reference channel level to make relative power measurements.

Average - Sets the average power level of two carriers to the reference channel level to make relative power measurements.

- **Meas Mode** - Allows you to access the following menu to select one of the measurement modes:

All Channels - Measures the power levels of all offset channels including the offset channels between two carrier channels depending on the selection of **2nd Carrier Offset**, along with the two carrier levels.

3rd IM Only - Measures the third order intermodulation product levels depending on the selection of **2nd Carrier Offset**, along with two carrier levels.

3rd/5th/7th IM - Measures the third, fifth, and seventh orders intermodulation product levels depending on the selection of **2nd Carrier Offset**, along with two carrier levels.

- **Ofs & Limits** - Allows you to access the menu to change the following parameters and pass/fail tests for each offset. If one limit test fails, the red character F is shown on the right side of the measured value and the corresponding bar changes its color to red.

Offset - Allows you to access the memory selection menu from **A** to **D** to store 4 sets of test conditions. Frequencies are automatically specified according to the selection of the second carrier offset. Only one selection at a time (A, B, C, D, or E) is shown on this key label.

Abs Limit - Allows you to enter an absolute limit value ranging from -200.00 to $+50.00$ dBm with 0.01 dB resolution.

Fail - Allows you to access the following menu to select one of the logic keys for fail conditions between the measurement results and the test limits:

AND - Fail is shown if one of the relative power measurement results is larger than the limit for **Rel Lim (Car)** AND one of the absolute power measurement results is larger than the limit for **Abs Limit**.

OR - Fail is shown if one of the relative power measurement results is larger than the limit for **Rel Lim (Car)** OR one of the absolute power measurement results is larger than the limit for **Abs Limit**.

Absolute - Fail is shown if one of the absolute power measurement results is larger than the limit for **Abs Limit**.

Relative - Fail is shown if one of the relative power measurement results is larger than the limit for **Rel Lim (Car)**.

Rel Lim (Car) - Allows you to enter a relative limit value of the carrier level ranging from -200.00 to $+50.00$ dBc with 0.01 dB resolution.

- **Advanced** - Allows you to access the following menu:

RRC Filter - Allows you to toggle the root raised cosine filter function between **On** and **Off**.

Alpha - Allows you to set the Alpha value of RRC Filter. The range is 0.010 to 0.500.

Changing the View

The **View/Trace** key is not available for this measurement.

Changing the Display

The **Display** key reveals the following menu to change the bar colors of the carriers and offset channels:

- **Bar Colors** - Allows you to access the menu to change the bar color of each bar in the graph:

Center Car - Allows you to access the color selection menu from **White** to **Green** for the center carrier bar. The default selection is **Yellow** as shown on this key label. The following color menu is common to others:

- **White**
- **Medium Gray**
- **Blue**
- **Sky Blue**
- **Purple**
- **Yellow**
- **Green**

2nd Car - Allows you to access the color selection menu from **White** to **Green** for the second carrier bar. The default selection is **Yellow** as shown on this key label.

-5 MHz Ofs Ch - Allows you to access the color selection menu from **White** to **Green** for the -5 MHz offset channel bar. The default selection is **Sky Blue** as shown on this key label.

5 MHz Ofs Ch - Allows you to access the color selection menu from **White** to **Green** for the 5 MHz offset channel bar. The default selection is **Green** as shown on this key label.

10 MHz Ofs Ch - Allows you to access the color selection menu from **White** to **Green** for the 10 MHz offset channel bar. The default selection is **Green** as shown on this key label.

15 MHz Ofs Ch - Allows you to access the color selection menu from **White** to **Green** for the 15 MHz offset channel bar. The default selection is **Green** as shown on this key label.

Using the Marker

The **Marker** key is not available for this measurement.

Troubleshooting Hints

If there is a frequency channel dependency in the operating characteristics of a multi carrier power amplifier, it is supposed that this amplifier might have channel balance problems due to spurious response, distortion, and/or intermodulation products.

Making the Spectrum Emission Mask Measurement

Purpose

Spectrum Emission Mask measurement includes the in-band and out-of-band spurious emissions. As it applies to W-CDMA (3GPP), this is the power contained in a specified frequency bandwidth at certain offsets relative to the total carrier power. It may also be expressed as a ratio of power spectral densities between the carrier and the specified offset frequency band.

As a composite measurement of out-of-channel emissions, spectrum emission mask measurement combines both in-band and out-of-band specifications to provide useful figures-of-merit for spectral regrowth and emissions produced by components and circuit blocks without the rigor of performing a full spectrum emissions mask measurement.

Measurement Method

The spectrum emission mask measurement measures spurious signal levels in up to five pairs of offset/region frequencies and relates them to the carrier power. A reference channel integration bandwidth method is used to measure the carrier channel power and offset/region powers. With “Offset” selected, spectrum emission mask measurements are made with both sides centered at the carrier channel frequency bandwidth. With “Region” selected, spurious emission measurements are made at any specified start and stop RF frequencies with the restriction of the frequency range from 329 MHz to 3.678 GHz, and the measurement screen is titled Spurious Emission.

This integration bandwidth method performs a time domain data acquisition and applies FFT to get a frequency domain trace. In this process, the reference channel integration bandwidth is analyzed using the automatically defined resolution bandwidth (Res BW), which is much narrower than the channel bandwidth. The measurement computes an average power of the channel or offset/region over a specified number of data acquisitions, automatically compensating for resolution bandwidth and noise bandwidth.

This measurement requires the user to specify measurement bandwidths of the carrier channel and each of the offset/region frequency pairs up to 5. Each pair may be defined with unique measurement bandwidths. The results are displayed both as relative power in dBc, and as absolute power in dBm.

Making the Measurement

NOTE

The factory default settings provide a good starting point. For special requirements, you may need to change some of the settings. Press **Meas Setup, More (1 of 2), Restore Meas Defaults** at any time to return all parameters for the current measurement to their default settings.

Select the desired center frequency as described in [“Changing the Frequency Channel” on page 23](#).

Press **MEASURE, Spectrum Emission Mask** to immediately make a spectrum emission mask measurement.

To change any of the measurement parameters from the factory default values, refer to [“Changing the Measurement Setup” on page 92](#).

Results

The next figure shows an example result of Spectrum (Ref: Total Pwr, Seg: Offset) measurements in the graph window. The absolute peak power levels and those corresponding offset frequency ranges on both sides of the reference channel are displayed in the text window.

Figure 3-7

Spectrum Emission Mask Measurement - Total Pwr Ref & Offset View

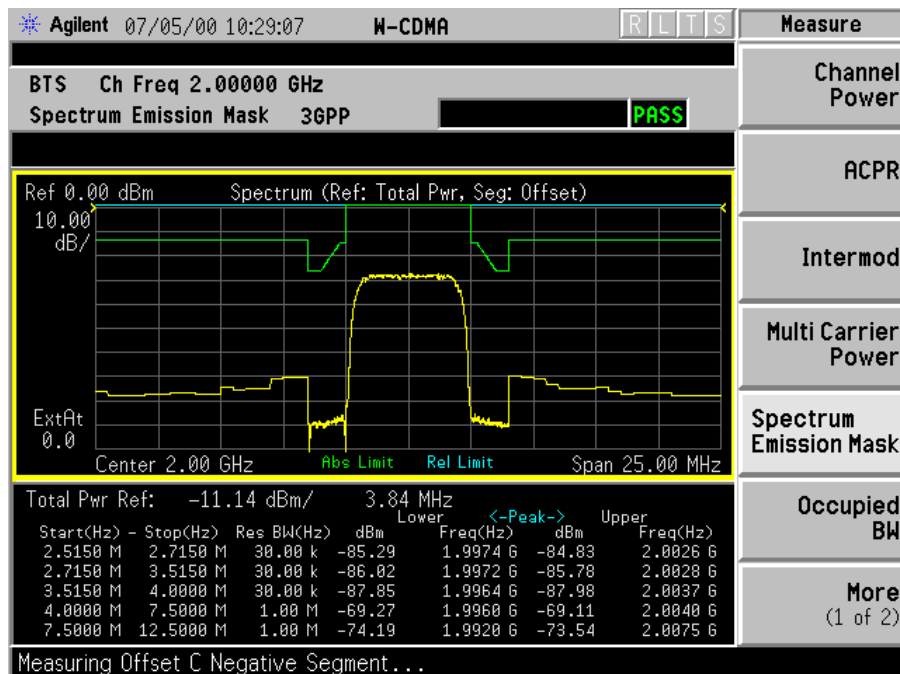

Changing the Measurement Setup

The next table shows the factory default settings for spectrum emission mask measurements.

Table 3-5 Spectrum Emission Mask Measurement Defaults

Measurement Parameter	Factory Default Condition
View/Trace	All
Display:	Abs Peak Pwr & Freq
Limit Lines	On
Meas Setup:	
Avg Number	10, Off
Meas Interval	1.000 ms
Ref Channel:	
Chan Integ BW	3.84000 MHz
Chan Span	5.00000 MHz
Step Freq	38.400 kHz, Auto
Res BW	76.800 kHz, Auto
Spectrum Segment	Offset
Ofs & Limits:	(Refer to Table 3-6 on page 96)
Offset	A
Start Freq	2.51500 MHz, On
Stop Freq	2.71500 MHz
Step Freq	15.000 kHz, Auto
Res BW	30.000 kHz, Man
Limits:	
Abs Start	-14.00 dBm
Abs Stop	-14.00 dBm, Couple
Rel Start	-30.00 dBc
Rel Stop	-30.00 dBc, Couple
Fail	Absolute
Ofs & Limits Advanced:	
Relative Att	0.00 dB
Offset Side	Both
Detector	Avg (average)
Meas Type	Total Pwr Ref
Trig Source	Free Run (Immediate)

Make sure the **Spectrum Emission Mask** measurement is selected under the **MEASURE** menu. The **Meas Setup** key accesses the menus which allow you to modify the average number, average mode, and trigger source for this measurement as described in “[Measurement Setup](#)” on [page 58](#).

In addition, the following parameters can be changed according to your measurement requirement:

- **Meas Interval** - Allows you to specify the measurement interval ranging from 0.1 to 10.0 ms with 0.001 ms resolution.
- **Ref Channel** - Allows you to define the reference channel in the following terms:
 - Chan Integ BW** - Allows you to specify the channel integration bandwidth ranging from 100.0 kHz to the setting of **Chan Span**.
 - Chan Span** - Allows you to specify the channel span to be measured ranging from 100.000 kHz to 10.0000 MHz.
 - Step Freq** - Allows you to specify the step frequency to make measurements ranging from 100.0 Hz to 7.50000 MHz, and to toggle this function between **Auto** and **Man**. If set to **Auto**, this is automatically set to a half of **Res BW**. If set to **Man**, this is manually set independently from **Res BW**.
 - Res BW** - Allows you to specify the resolution bandwidth ranging from 1.000 kHz to 7.50000 MHz, and to toggle this function between **Auto** and **Man**. If set to **Auto**, **Res BW** is automatically set to one 50th of **Chan Integ BW**.
- **Spectrum Segment** - Allows you to toggle the frequency spectrum segment between **Offset** and **Region**. Upon selecting **Offset**, spectrum emission mask measurements are made, and upon selecting **Region**, spurious emission measurements are made. According to this selection there are two types of offsets and limits menus; **Offset/Limits** and **Region/Limits**.

- **Offset/Limits** - Allows you to access the menus to change the following parameters for offset frequency settings and pass/fail tests, if **Spectrum Segment** is set to **Offset**. [Table 3-6 on page 96](#) and [Table 3-7 on page 96](#) show the default setting for BTS and MS measurements, respectively.

Offset - Allows you to access the memory selection menu from **A** to **E** to store up to 5 sets of values for **Start Freq**, **Stop Freq**, **Step Freq**, **Res BW**, **Limits** and so forth. Only one selection at a time is shown on this key label.

Start Freq - Allows you to specify the start frequency, and to toggle this function between **On** and **Off**, for each offset. The frequency range is 10.000 kHz to 100.000 MHz with 100 Hz resolution, however, the higher range is limited to the setting of **Stop Freq**.

Stop Freq - Allows you to specify the stop frequency ranging from 10.000 kHz to 100.000 MHz with 100 Hz resolution, for each offset. The lower range is limited to the setting of **Start Freq**.

Step Freq - Allows you to specify the step frequency ranging from $(\text{Stop Freq} - \text{Start Freq})/10000$ to $(\text{Stop Freq} - \text{Start Freq})$, and to toggle this function between **Auto** and **Man**, for each offset. If set to **Auto**, this is automatically set to a half of **Res BW**.

Res BW - Allows you to specify the resolution bandwidth ranging from 300.0 Hz to 7.50000 MHz with 100 Hz resolution, and to toggle this function between **Auto** and **Man**, for each offset. If set to **Auto**, this is automatically set to one 50th of $(\text{Stop Freq} - \text{Start Freq})$.

Limits - Allows you to access the following menu to set up absolute and relative level limits and fail conditions for each offset:

- **Abs Start** - Allows you to enter an absolute level limit at **Start Freq** ranging from -200.00 to +50.00 dBm with 0.01 dB resolution.
- **Abs Stop** - Allows you to enter an absolute level limit at **Stop Freq** ranging from -200.00 to +50.00 dBm with 0.01 dB resolution, and to toggle this function between **Couple** and **Man**. If set to **Couple**, this is coupled to **Abs Start** to make a flat limit line. If set to **Man**, **Abs Start** and **Abs Stop** can take different values to make a sloped limit line.
- **Rel Start** - Allows you to enter a relative level limit at **Start Freq** ranging from -150.00 to +50.00 dBc with 0.01 dB resolution.

- **Rel Stop** - Allows you to enter a relative level limit at **Stop Freq** ranging from -150.00 to $+50.00$ dBc with 0.01 dB resolution, and to toggle this function between **Couple** and **Man**. If set to **Couple**, this is coupled to **Rel Start** to make a flat limit line. If set to **Man**, **Rel Start** and **Rel Stop** can take different values to make a sloped limit line.
- **Fail** - Allows you to access the following menu to select one of the logic keys for fail conditions between the measurement results and the test limits:

AND - Fail is shown if one of the relative spectrum emission mask measurement results is larger than the limit for **Rel Start** and **Rel Stop** AND one of the absolute spectrum emission mask measurement results is larger than the limit for **Abs Start** and **Abs Stop**.

OR - Fail is shown if one of the relative spectrum emission mask measurement results is larger than the limit for **Rel Start** and **Rel Stop** OR one of the absolute spectrum emission mask measurement results is larger than the limit for **Abs Start** and **Abs Stop**.

Absolute - Fail is shown if one of the absolute spectrum emission mask measurement results is larger than the limit for **Abs Start** and/or **Abs Stop**. This is the default selection for each offset.

Relative - Fail is shown if one of the relative spectrum emission mask measurement results is larger than the limit for **Rel Start** and/or **Rel Stop**.

Offset Adv - Allows you to access the following advanced menu:

- **Relative Att** - Allows you to enter an attenuation value to adjust the relative level limits ranging from -40.00 to 40.00 dB with 0.01 dB resolution. The defaulted attenuation is same to one used by **Ref Channel**.
- **Offset Side** - Allows you to specify which offset side to be measured. Selections are **Neg** (negative offset), **Both**, and **Pos** (positive offset).

Table 3-6 Offsets & Limits Defaulted for BTS Measurements

Offset	Start Freq (MHz)	Stop Freq (MHz)	Step Freq (kHz)	Res BW (kHz)	Abs Start (dBm)	Abs Stop (dBm)	Rel Start (dBc)	Rel Stop (dBc)	Fail
A, On	2.515	2.715	15.00	30.00	-14.00	-14.00	-30.00	-30.00	Abs
B, On	2.715	3.515	15.00	30.00	-14.00	-26.00	-30.00	-30.00	Abs
C, On	3.515	4.000	15.00	30.00	-26.00	-26.00	-30.00	-30.00	Abs
D, On	4.000	7.500	500.00	1000.0	-13.00	-13.00	-30.00	-30.00	Abs
E, On	7.500	12.500	500.00	1000.0	-13.00	-13.00	-30.00	-30.00	Abs

Table 3-7 Offsets & Limits Defaulted for MS Measurements

Offset	Start Freq (MHz)	Stop Freq (MHz)	Step Freq (kHz)	Res BW (kHz)	Abs Start (dBm)	Abs Stop (dBm)	Rel Start (dBc)	Rel Stop (dBc)	Fail
A, On	2.515	3.485	15.00	30.00	-71.07	-71.07	-35.23	-49.78	AND
B, On	4.000	7.500	500.00	1000.0	-55.84	-55.84	-35.50	-39.00	AND
C, On	7.500	8.500	500.00	1000.0	-55.84	-55.84	-39.00	-49.00	AND
D, On	8.500	12.000	500.00	1000.0	-55.84	-55.84	-49.00	-49.00	AND
E, Off	12.500	15.000	500.00	1000.0	-55.84	-55.84	-49.00	-49.00	AND

- **Region/Limits** - Allows you to access the menus to change the following parameters for region frequency settings and pass/fail tests, if **Spectrum Segment** is set to **Region**. [Table 3-8 on page 99](#) and [Table 3-9 on page 99](#) show the default setting for BTS and MS measurements, respectively.

Region - Allows you to access the memory selection menu from **A** to **E** to store up to 5 sets of values for **Start Freq**, **Stop Freq**, **Step Freq**, **Res BW**, **Limits** and so forth. Only one selection at a time is shown on this key label. The default selection is **A**.

Start Freq - Allows you to specify the start frequency, and to toggle this function between **On** and **Off**, for each region. The frequency range is 329.000 MHz to 3.67800 GHz with 1 kHz resolution, however, the higher range is limited to the setting of **Stop Freq**.

Stop Freq - Allows you to specify the stop frequency ranging from 329.000 MHz to 3.67800 GHz with 1 kHz resolution, for each region. The lower range is limited to the setting of **Start Freq**.

Step Freq - Allows you to specify the step frequency ranging from $(\text{Stop Freq} - \text{Start Freq})/10000$ to $(\text{Stop Freq} - \text{Start Freq})$, and to toggle this function between **Auto** and **Man**, for each region. If set to **Auto**, this is automatically set to a half of **Res BW**.

Res BW - Allows you to specify the resolution bandwidth ranging from 1.000 kHz to 7.50000 MHz with 1 kHz resolution, and to toggle this function between **Auto** and **Man**, for each region. If set to **Auto**, this is automatically set to one 50th of $(\text{Stop Freq} - \text{Start Freq})$.

Limits - Allows you to access the following menu to set up absolute and relative level limits and fail conditions for each region:

- **Abs Start** - Allows you to enter an absolute level limit at **Start Freq** ranging from -200.00 to $+50.00$ dBm with 0.01 dB resolution.
- **Abs Stop** - Allows you to enter an absolute level limit at **Stop Freq** ranging from -200.00 to $+50.00$ dBm with 0.01 dB resolution, and to toggle this function between **Couple** and **Man**. If set to **Couple**, this is coupled to **Abs Start** to make a flat limit line. If set to **Man**, **Abs Start** and **Abs Stop** can take different values to make a sloped limit line.
- **Rel Start** - Allows you to enter a relative level limit ranging from -150.00 to $+50.00$ dBc with 0.01 dB resolution.
- **Rel Stop** - Allows you to enter a relative level limit at **Stop Freq** ranging from -150.00 to $+50.00$ dBc with 0.01 dB resolution, and to toggle this function between **Couple** and **Man**. If set to **Couple**, this is coupled to **Rel Start** to make a flat limit line. If set to **Man**, **Rel Start** and **Rel Stop** can take different values to make a sloped limit line.
- **Fail** - Allows you to access the following menu to select one of the logic keys for fail conditions between the measurement results and the test limits:

AND - Fail is shown if one of the relative spurious emission measurement results is larger than the limit for **Rel Start** and **Rel Stop** AND one of the absolute spurious emission mask measurement results is larger than the limit for **Abs Start** and **Abs Stop**.

OR - Fail is shown if one of the relative spurious emission measurement results is larger than the limit for **Rel Start** and **Rel Stop** OR one of the absolute spurious emission measurement results is larger than the limit for **Abs Start** and **Abs Stop**.

Absolute - Fail is shown if one of the absolute spectrum emission mask measurement results is larger than the limit for **Abs Start** and **Abs Stop**. This is the default selection for each region.

Relative - Fail is shown if one of the relative spurious emission measurement results is larger than the limit for **Rel Start** and **Rel Stop**.

Region Adv - Allows you to access the following advanced menu:

- **Relative Att** - Allows you to enter an attenuation value to adjust the relative level limits ranging from -40.00 to 40.00 dB with 0.01 dB resolution. The defaulted attenuation is same to one used by **Ref Channel**.

Table 3-8 Regions & Limits Defaulted for BTS Measurements

Region	Start Freq (GHz)	Stop Freq (GHz)	Step Freq (kHz)	Res BW (kHz)	Abs Start (dBm)	Abs Stop (dBm)	Rel Start (dBc)	Rel Stop (dBc)	Fail
A, On	1.9200	1.9800	600.0	1200.0	-50.00	-50.00	-30.00	-30.00	Abs
B, On	1.8935	1.9196	261.0	522.0	-50.00	-50.00	-30.00	-30.00	Abs
C, On	2.1000	2.1050	50.0	100.0	-50.00	-50.00	-30.00	-30.00	Abs
D, Off	2.1750	2.1800	50.0	100.0	-50.00	-50.00	-30.00	-30.00	Abs
E, Off	0.8000	1.0000	2000.0	4000.0	-50.00	-50.00	-30.00	-30.00	Abs

Table 3-9 Regions & Limits Defaulted for MS Measurements

Region	Start Freq (GHz)	Stop Freq (GHz)	Step Freq (kHz)	Res BW (kHz)	Abs Start (dBm)	Abs Stop (dBm)	Rel Start (dBc)	Rel Stop (dBc)	Fail
A, On	1.9200	1.9800	600.0	1200.0	-50.00	-50.00	-30.00	-30.00	Abs
B, On	1.8935	1.9196	261.0	522.0	-50.00	-50.00	-30.00	-30.00	Abs
C, On	2.1000	2.1050	50.0	100.0	-50.00	-50.00	-30.00	-30.00	Abs
D, Off	2.1750	2.1800	50.0	100.0	-50.00	-50.00	-30.00	-30.00	Abs
E, Off	0.8000	1.0000	2000.0	4000.0	-50.00	-50.00	-30.00	-30.00	Abs

- **Detector** - Allows you to toggle the power detection type between **Avg** (average) and **Peak**. If set to **Avg**, the power in a bin is computed as RMS averaged over the entire **Meas Interval**. If set to **Peak**, the peak power in the entire **Meas Interval** is converted to the RMS value assuming of continuous wave signal.
- **Meas Type** - Allows you to access the menu to select one of the measurement reference types.
 - Total Pwr Ref** - Sets the reference to the total carrier power and the measured data is shown in dBc and dBm.
 - PSD Ref** - Sets the reference to the mean power spectral density of the carrier and the measured data is shown in dB and dBm/Hz.
- **Trig Source** - Allows you to select one of the trigger sources from **Free Run (Immediate)**, **Ext Front**, **Ext Rear**, **Frame**, and **Line**. It is defaulted to **Free Run (Immediate)**.

Changing the View

The **View/Trace** key accesses the menu to select the desired view of the measurement result according to the selection of **Spectrum Segment**.

If **Spectrum Segment** is set to **Offset**, the next menu is shown:

- **All** - In the factory default condition, the spectrum emission mask measurement graph is displayed with all of the active offsets in the graph window as shown in [Figure 3-7 on page 91](#).
- **Offset A to Offset E** - Each of spectrum emission mask measurement results up to 5 sets of offsets is shown in the graph window. In the factory default condition, **Offset D** and **Offset E** are defaulted to **Off** resulting in gray labels.
- **Offset** - Allows you to toggle the display function of the offset sides between **Neg** (negative) and **Pos** (positive).

If **Spectrum Segment** is set to **Region**, the next menu is shown:

- **All** - The spurious emission measurement graph is displayed with all of the active regions in the graph window as shown below.

Figure 3-8 Spurious Emission Measurement - All Regions View

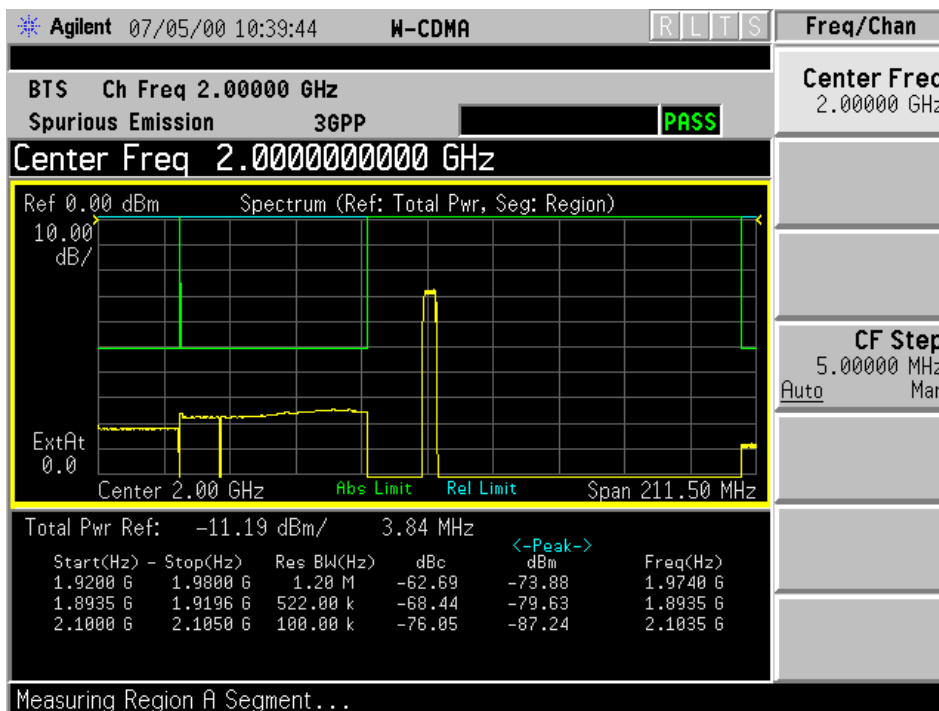

- **Region A to Region E** - Each of spurious emission measurement results up to 5 sets of regions is shown in the graph window. In the factory default condition, **Region D** and **Region E** are defaulted to **Off** resulting in gray labels.

Changing the Display

The **AMPLITUDE Y Scale** key accesses the menu to allow the following settings for desired graph displays:

- **Scale/Div** - Allows you to enter a numeric value to change the vertical display sensitivity. The range is 0.10 to 20.00 dB with 0.01 dB resolution. The default setting is 10.00 dB, however, since the **Scale Coupling** is defaulted to **On**, this value is automatically determined by the measurement result.
- **Ref Value** - Allows you to set the absolute power reference value ranging from -250.00 to 250.00 dBm with 0.01 dB resolution. The default setting is 10.00 dBm, however, since the **Scale Coupling** is defaulted to **On**, this value is automatically determined by the measurement result.
- **Ref Position** - Allows you to set the reference position to either **Top**, **Ctr** (center), or **Bot** (bottom). The default setting is **Top**.
- **Scale Coupling** - Allows you to toggle the scale coupling function between **On** and **Off**. The default setting is **On**. Upon pressing the **Restart** front-panel key or **Restart** softkey under the **Meas Control** menu, this function automatically determines the scale per division and reference values by the measurement results.

The **Display** key also accesses the menu to allow the following selections to control the screen display:

- **Limit Lines** - Allows you to toggle the limit lines display function for spectrum emission mask measurements between **On** and **Off**. If set to **On**, the absolute limit lines and the relative limit lines are shown on the spectrum emission mask measurement display.

One of the following three keys can be selected to control the power level units. These are disabled if **Spectrum Segment** is set to **Region**.

- **Abs Peak Pwr & Freq** - Allows you to read the absolute peak power levels in dBm and corresponding frequencies in the text window.
- **Rel Peak Pwr & Freq** - Allows you to read the relative peak power levels in dBc and corresponding frequencies in the text window.
- **Integrated Power** - Allows you to read the absolute and relative power levels integrated throughout the bandwidths between the start and stop frequencies in the text window.

Troubleshooting Hints

This spectrum emission mask measurement can reveal degraded or defective parts in the transmitter section of the UUT. The following examples are those areas to be checked further.

- Some faults in the DC power supply control of the transmitter power amplifier, RF power controller of the pre-power amplifier stage, or I/Q control of the baseband stage
- Some degradation in the gain and output power level of the amplifier due to the degraded gain control and/or increased distortion
- Some degradation of the amplifier linearity and other performance characteristics

Power amplifiers are one of the final stage elements of a base or mobile transmitter and are a critical part of meeting the important power and spectral efficiency specifications. Since spectrum emission mask measures the spectral response of the amplifier to a complex wideband signal, it is a key measurement linking amplifier linearity and other performance characteristics to the stringent system specifications.

Making the Occupied Bandwidth Measurement

Purpose

Occupied bandwidth measures the bandwidth containing 99.0% of the total power.

The spectrum shape of a W-CDMA (3GPP) signal can give useful qualitative insight into transmitter operation. Any distortion to the spectrum shape can indicate problems in transmitter performance.

Measurement Method

The transmitter tester uses digital signal processing (DSP) to sample the input signal and convert it to the frequency domain. With the instrument tuned to a fixed center frequency, samples are digitized at a high rate with DSP hardware, and then converted to the frequency domain with FFT software.

The total absolute power within the measurement frequency span is integrated for its 100% of power. Two frequencies containing 0.5% each of the total power are then calculated to get 99.0% bandwidth.

Making the Measurement

NOTE

The factory default settings provide a good starting point. For special requirements, you may need to change some of the settings. Press **Meas Setup, More (1 of 2), Restore Meas Defaults** at any time to return all parameters for the current measurement to their default settings.

Select the desired center frequency as described in [“Changing the Frequency Channel” on page 23](#).

Press **MEASURE, Occupied BW** to immediately make an occupied bandwidth measurement.

To change any of the measurement parameters from the factory default values, refer to [“Changing the Measurement Setup” on page 105](#).

Results

The next figure shows an example result of Occupied BW measurements. The occupied bandwidth graph is shown in the graph window. The occupied bandwidth for 99.00% of the total power and the total power level are shown in the text window.

Figure 3-9

Occupied Bandwidth Measurement

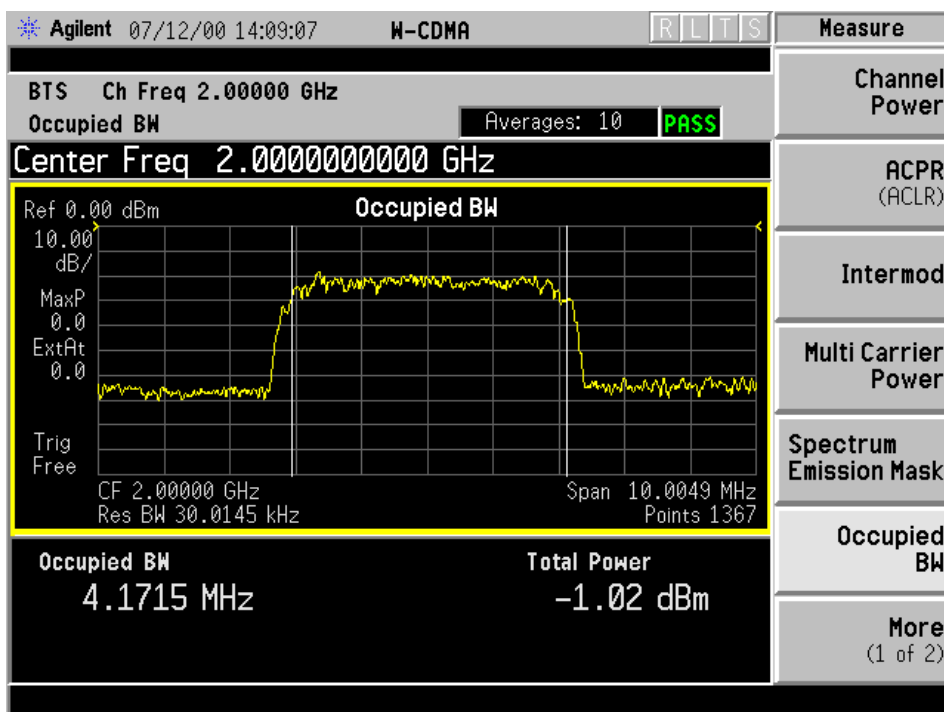

Changing the Measurement Setup

The next table shows the factory default settings for occupied bandwidth measurements.

Table 3-10 Occupied Bandwidth Measurement Defaults

Measurement Parameter	Factory Default Condition
Meas Setup:	
Avg Number	10, On
Avg Mode	Repeat
Span	10.0000 MHz
Res BW	30.000 kHz
Trig Source	Free Run (Immediate)
FFT Window	Gaussian (Alpha 3.5)
Limit Test	On
Limit	5.00000 MHz

Make sure the **Occupied BW** measurement is selected under the **MEASURE** menu. The **Meas Setup** key accesses the menu which allows you to modify the average number, average mode, and trigger source for this measurement as described in “[Measurement Setup](#)” on page 58.

In addition, the following parameters can be changed according to your measurement requirement:

- **Span** - Allows you to specify the frequency span in which the total power is measured. The range is 10.000 kHz to 10.0000 MHz with 1 Hz resolution.
- **Res BW** - Allows you to specify the resolution bandwidth value. The frequency range is 1.000 kHz to 1.00000 MHz. A narrower bandwidth will result in a longer data acquisition time but you will be able to examine the signal more closely.
- **Limit Test** - Allows you to toggle the limit test function for occupied bandwidth measurements between **On** and **Off**.
- **Limit** - Allows you to specify the limit frequency value with which the limit test is made. The range is 10.000 kHz to 10.0000 MHz with 100 Hz resolution.

- **Advanced** - Allows you to access the selection menu of FFT windows.

FFT Window - Allows you to access the following selection menu for FFT windows. If you are familiar with FFT windows, you can use other digital filters but the use of the flat top filter is recommended. Changes from the default setting may result in invalid data.

Flat Top - Select this filter for best amplitude accuracy by reducing scalloping error.

Uniform - Select this filter to have no active window.

Hanning - Press this key to activate the Hanning filter.

Hamming - Press this key to activate the Hamming filter.

Gaussian (Alpha 3.5) - Press this key to activate the Gaussian filter with an alpha of 3.5.

Blackman - Press this key to activate the Blackman filter.

Blackman-Harris - Press this key to activate the Blackman-Harris filter.

K-B 70dB/90dB/110dB (Kaiser-Bessel) - Allows you to select one of the Kaiser-Bessel filters with sidelobes at -70, -90, or -110 dB.

Changing the View

The **View/Trace** key is not available for this measurement function.

Changing the Display

The **Display** key is not available for this measurement function.

The **AMPLITUDE Y Scale** key accesses the menu to allow the following settings for desired graph displays:

- **Scale/Div** - Allows you to enter a numeric value to change the vertical display sensitivity. The range is 0.10 to 20.00 dB with 0.01 dB resolution. The default setting is 10.00 dB, however, since the **Scale Coupling** is defaulted to **On**, this value is automatically determined by the measurement result.
- **Ref Value** - Allows you to set the absolute power reference value ranging from -250.00 to 250.00 dBm with 0.01 dB resolution. The default setting is 10.00 dBm, however, since the **Scale Coupling** is defaulted to **On**, this value is automatically determined by the measurement result.
- **Ref Position** - Allows you to set the reference position to either **Top**, **Ctr** (center), or **Bot** (bottom). The default setting is **Top**.
- **Scale Coupling** - Allows you to toggle the scale coupling function between **On** and **Off**. The default setting is **On**. Upon pressing the **Restart** front-panel key or **Restart** softkey under the **Meas Control** menu, this function automatically determines the scale per division and reference values by the measurement results.

Using the Marker

The **Marker** key is not available for this measurement function.

Troubleshooting Hints

Any distortion such as harmonics or intermodulation, for example, produces undesirable power outside the specified bandwidth.

Shoulders on either side of the spectrum shape indicate spectral regrowth and intermodulation. Rounding or sloping of the top shape can indicate filter shape problems.

Making the Code Domain Measurement

Purpose

Since the code domain measurements despread and decode the W-CDMA (3GPP) signal into its physical channels, the number of active channels of various symbol rates (which are denoted by widths) can be observed. The width of the channel is inversely proportional to the Orthogonal Variable Spreading Factor (OVSF) code length in number of bits. In the code domain, there is a fixed amount of code space for a given chip rate. Therefore, by using the different OVSF codes, the system can dynamically allocate the code space for lower rate voice users versus high speed data users.

This code domain power composite view provides information about the in-channel characteristics of the W-CDMA (3GPP) signal. It directly informs the user of the active channels with their individual channel powers. The composite view also shows which data rates are active and the corresponding amount of code space used. The following are conditions under which a general unlock can occur: the CPICH or SCH signal is too low in power or no such signal is available for BTS measurements, the DPCH signal is too low in power or no such signal available for MS measurements, an incorrect long code is used for despreading, the frequency error is too large, or a frequency inversion is present.

When the level of the code domain noise floor is too high, relative to a reference or an expected level, one of the possible causes might be due to CW interference, like local oscillator feedthrough or spurs. I/Q modulation impairments can be another source of this uncorrelated noise. The I/Q demodulation measurements can reveal errors such as I/Q gain imbalance or I/Q quadrature error.

Measurement Method

This procedure measures the power levels of the spread channels in composite RF channels. If **Device** is set to **MS**, the demodulated I and Q signals are individually shown in the code domain power graph window. One uniqueness from other measurements is that **Measure** in the **Meas Control** menu is defaulted to **Single**.

The code domain measurement displays the power for each of the spread channels, relative to the total power within the 3.840 MHz channel bandwidth centered at the center frequency. Each spread channel level is displayed as an individual vertical bar with a different width determined by a spread rate. Because this is a relative measurement, the unit of measure is defaulted to dBc, however, **Meas Type** toggles the power unit between **Abs** (absolute) and **Rel** (relative).

The following displays are available for this measurement:

- Power Graph & Metrics - The transmitted energy associated with each of the symbol rates and codes is shown in the graph window. The following powers along with the total power are shown in the text window if **Device** is set to **BTS**:
 - Total active channel power
 - CPICH channel power
 - PSCH channel power
 - SSCH channel power
 - Maximum active channel power
 - Average active channel power
 - Maximum inactive channel power
 - Average inactive channel power
 - Number of active channels

The following powers along with the total power are shown in the text window if **Device** is set to **MS**:

- Total active channel power
- DPCCH channel power
- DPCCH Beta factor
- DPDCH Beta factors: C1 to C6 factors
- I average active channel power
- I maximum inactive channel power
- Q average inactive channel power
- Q maximum inactive channel power
- I/Q Error (Quad View) - The magnitude error, phase error, and EVM graphs are individually shown in the graph windows. The summary data for these parameters are also shown in the text window.
- Code Domain (Quad View) - The graphs of the code domain power, the symbol power for the selected spread channel, and the symbol EVM polar vector for the symbol power selected by the measurement interval and measurement offset, are shown in the graph windows. The symbol EVM summary data is also shown in the text window.
- Demod Bits - In addition to the graphs of the code domain power and symbol power for the selected spread channel, the demodulated bit stream data can be shown for the symbol power slots selected by the measurement interval and measurement offset in the text window.

Making the Measurement

NOTE

The factory default settings provide a good starting point. For special requirements, you may need to change some of the settings. Press **Meas Setup, More (1 of 2), Restore Meas Defaults** at any time to return all parameters for the current measurement to their default settings.

Select the desired center frequency as described in [“Changing the Frequency Channel” on page 23](#).

Press **MEASURE, Code Domain** to immediately make a code domain power measurement.

To change any of the measurement parameters from the factory default values, refer to [“Changing the Measurement Setup” on page 111](#).

Results

The next figure shows an example result of Code Domain Power measurements. In the graph window, the active channel symbol rates are shown with those widths of the bars and the measured channel powers are shown with those heights. In addition to the total power, the power levels for the total active channels, CPICH channel, PSCH channel, SSCH channel, maximum active channel, average active channels, maximum inactive channel, average inactive channel, and number of active channels, are shown in the text window.

Figure 3-10

Code Domain Measurement - Power Graph View

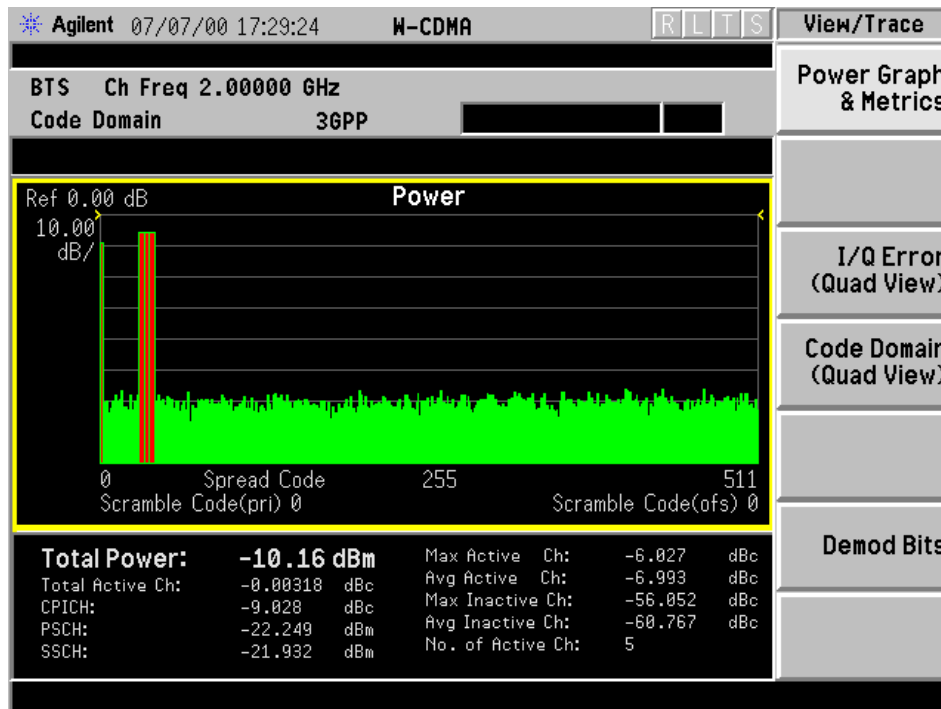

Changing the Measurement Setup

The next table shows the factory default settings for code domain power measurements.

Table 3-11 Code Domain Power Measurement Defaults

Measurement Parameter	Factory Default Condition
View/Trace	Power Graph & Metrics
Meas Setup:	
Meas Type	Rel (relative)
Symbol Rate	15.0 ksps
Code Number	0
I/Q Branch	Q (grayed out for BTS setting)
Meas Interval	1 slots
Meas Offset	0 slots
Sync Type	CPICH
P-Scramble Code	0
Scramble Code Type	Std (standard)
Scramble Code Offset	0
Capture Intvl	2 frames
Trig Source	Free Run (Immediate)
Spectrum	Normal
Meas Control: Measure	Single
Advanced	
Alpha	0.220
Chip Rate	3.840000 MHz

Make sure the **Code Domain** measurement is selected under the **MEASURE** menu. Press the **Meas Setup** key to access the menu which allows you to modify the average number, average mode, and trigger source for this measurement as described in [“Measurement Setup” on page 58](#). Also, press the **Meas Control** key to access the menu which allows you to change **Measure** from **Single** to **Cont** (continuous) as described in [“Measurement Control” on page 57](#).

In addition, the following parameters can be changed according to your measurement requirement:

- **Meas Type** - Allows you to toggle the power measurement type between **Abs** (absolute) and **Rel** (relative) to make the code domain power measurement. If set to **Rel**, the measurement is made in the relative power in dBc. If set to **Abs**, the measurement is made in the absolute power in dBm.
- **Symbol Rate** - Allows you to set the symbol rate ranging from 7.5 to 960 ksps. The parameter automatically sets the maximum value for **Code Number** when appropriate. If **Symbol Rate** is set to 15 ksps and **Code Number** is set to 0, the CPICH channel is automatically selected as the channel type.
- **Code Number** - Allows you to set the code number. The range is 0 to 511 depending on the **Symbol Rate** setting as follows:

Symbol Rate	Code Number	Description
7.5 ksps	0 to 511	Not available if Device is MS.
15 ksps	0 to 255	
30 ksps	0 to 127	
:	:	
480 ksps	0 to 7	
960 ksps	0 to 3	

- **I/Q Branch** - Allows you to toggle the selection of the branch signals between **I** and **Q**. The default selection is **Q**. This key is available if **Device** is set to **MS**.
- **Meas Interval** - Allows you to set the time interval in slots per frame over which the symbol power measurement is made. The range is 1 to 30 slots (15 slots/frame × **Capture Intvl** 2 frames) in conjunction with the **Meas Offset** value. The maximum value is 30 minus the **Meas Offset** value. The marker lines of which width proportionally varies with this number of slots are displayed in the symbol power graphs of the **Code Domain (Quad View)** and **Demod Bits** displays.
- **Meas Offset** - Allows you to set the number of offset slots to make the symbol power measurement. The range is 0 to 29 slots (15 slots/frame × **Capture Intvl** 2 frames – 1 slot) in conjunction with the **Meas Interval** value. The maximum value is 30 minus the **Meas Interval** value. The marker lines shift to right by this number of slots in the symbol power graphs of the **Code Domain (Quad View)** and **Demod Bits** displays.

- **Sync Type** - Allows you to access the following menu to select one channel to be synchronized with if **Device** is set to **BTS**:

CPICH - CPICH channel is set to synchronize with.

SCH - SCH channel is set to synchronize with.

If **Device** is set to **MS**, **DPCCH** is automatically set to the sync channel.

- **P-Scramble Code** - If **Device** is set to **BTS**, allows you to enter a numeric value for the primary scramble code. The range is 0 to 511.

If **Device** is set to **MS**, this label changes to **Scramble Code**, and allows you to enter a hexadecimal value for the scramble code. Pressing this key reveals the keys labeled **A** to **F** and **Done**. The range is 0000 to FFFFFFFF. Use these keys and the numeric keypad to enter a hexadecimal value by terminating with the **Done** key.

- **Scramble Code Type** - Allows you to set the scramble code type to either **Std** (standard), **Left**, or **Right** to make the code domain power measurement. This key is not available if **Device** is set to **MS**.
- **Scramble Code Offset** - Allows you to set the number of scramble code offsets (for selecting a secondary scramble code) to make the code domain power measurement. The range is 0 to 15. This key is not available if **Device** is set to **MS**.
- **Capture Intvl** - Allows you to set the number of frames to make the symbol power measurement. The range is 1 to 2 frames.
- **Spectrum** - Allows you to toggle the spectrum function between **Normal** and **Invert**. This key, when set to **Invert**, conjugates the spectrum, which equivalently negates the quadrature component in demodulation. The correct setting (**Normal** or **Invert**) depends on whether the signal being given to the transmitter tester has a high or low side mix.
- **Advanced** - Allows you to access the menu to set the following parameters.

Alpha - Allows you to specify the alpha value of the root-raised cosine filter. The range is 0.01 to 0.50.

Chip Rate - Allows you to change the chip rate. The range is 3.45600 to 4.22400 MHz.

Changing the View

The **View/Trace** key allows you to select the desired view of the measurement from the following. Each of these views contains multiple windows that can be selected by the **Next Window** key and made full size by the **Zoom** key.

- **Power Graph & Metrics** - Provides a combination view of the code domain power graph and the summary data as shown in [Figure 3-10 on page 110](#).
- **I/Q Error (Quad View)** - Provides a combination view of the magnitude error, phase error, EVM graphs, and the summary data such as the code number, rms EVM, peak EVM, magnitude error, phase error, total power, channel power, and tDPCH.

Figure 3-11 Code Domain Measurement - I/Q Error Quad View

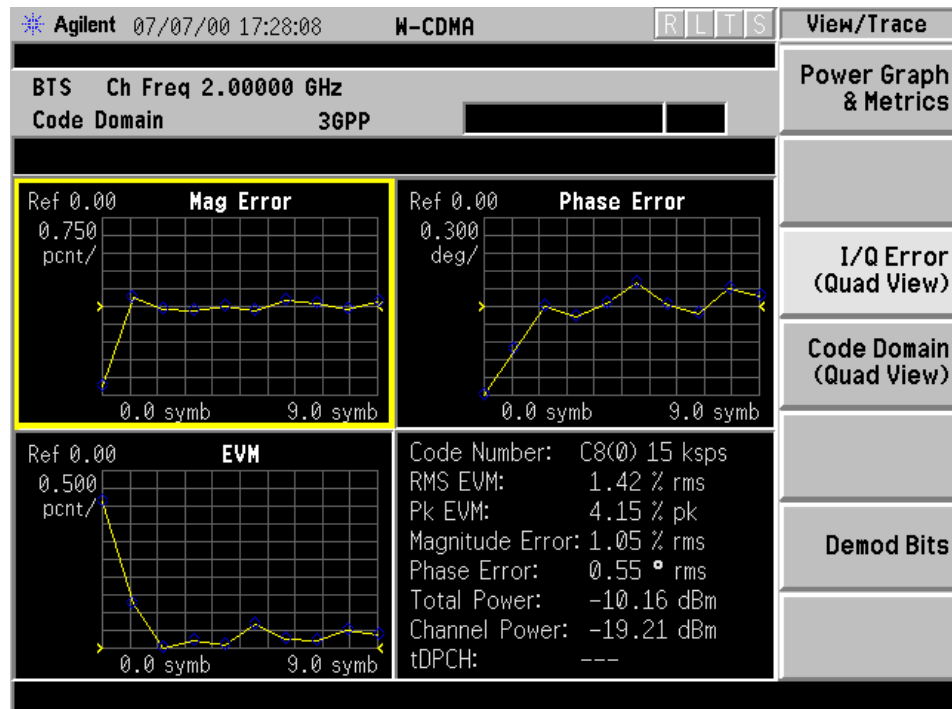

- **Code Domain (Quad View)** - Provides a combination view of the graphs for the code domain power, symbol power, I/Q symbol polar vector, and the summary data such as the code number, rms EVM, peak EVM, magnitude error, phase error, total power, channel power, and tDPCH.

Figure 3-12 Code Domain Measurement - Code Domain Quad View

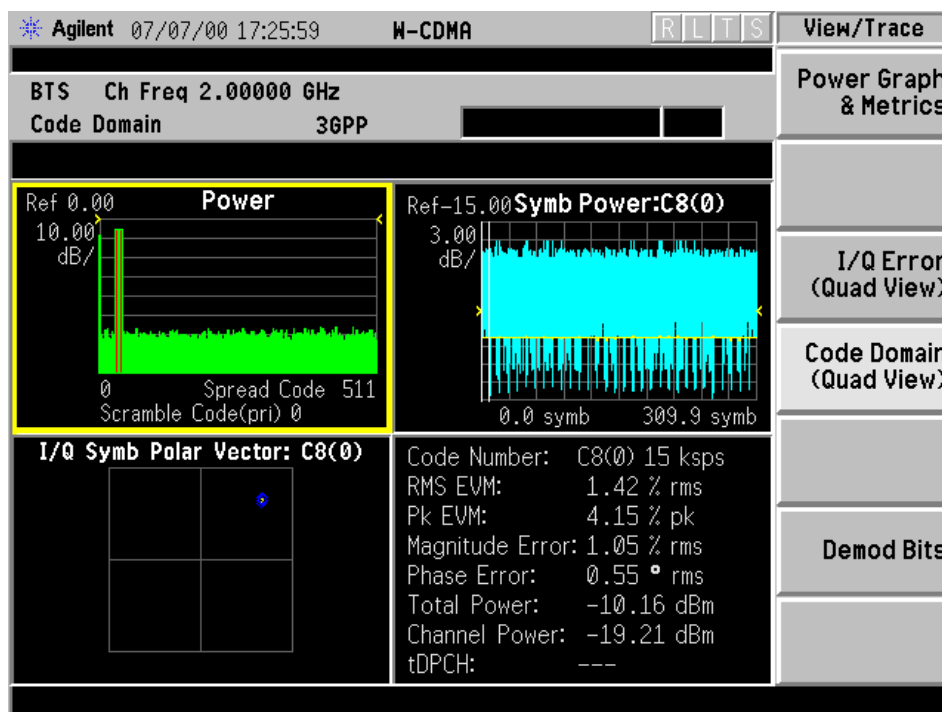

- **Demod Bits** - Provides a combination view of the graphs for the code domain power and symbol power in the graph window, and the I/Q demodulated bit stream data for the symbol power slots selected by the measurement interval and measurement offset in the text window.

Figure 3-13 Code Domain Measurement - Demod Bits View

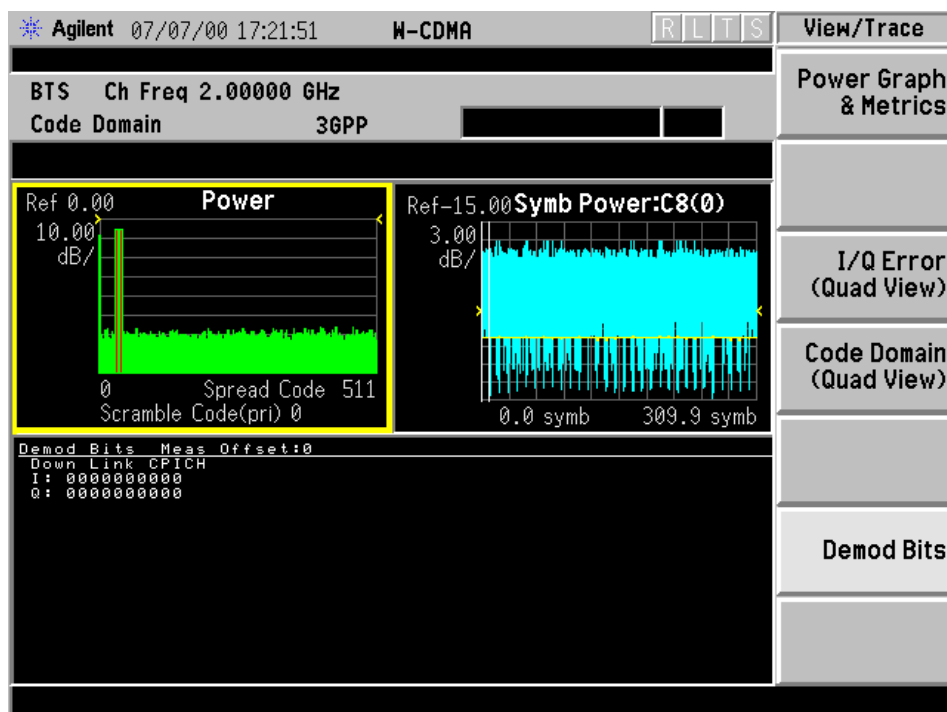

While the Code Domain Power graph is activated, press the **Marker** key to place a marker on any active spread channel. Then, press the **Mkr->Despread** key to observe the Symbol Power and the Symbol EVM Polar Vector graphs with the spread code number for that active channel in other graph windows. The symbol EVM polar vector graph and the demodulated bits are displayed for the symbol power specified by the measurement interval and measurement offset.

Changing the Display

The code domain measurement has no meaning in phase trajectories between constellation points for symbol EVM measurements. Therefore, the points per chip is always set to 1 and **Chip Dots** is set to **On**.

The **Display**, **SPAN X Scale**, and **AMPLITUDE Y Scale** keys are available according to the view/trace selected as follows.

- If the **Symb Power** window is active while **View/Trace** is set to **Code Domain (Quad View)** or **Demod Bits**, the **Display** key reveals the next key:
 - Composite Chip Power** - Allows you toggle the composite chip power display function between **On** and **Off**. The default setting is **On**.
- If the **Demod Bits** window is active when **View/Trace** is set to **Demod Bits**, the **Display** key accesses the menu to allow the following controls to read the bit stream measurement results:
 - Prev Page** - Returns one page back to the previous page of the measurement results.
 - Next Page** - Moves one page forward to the next page of the measurement results.
 - Scroll Up** - Moves one line upward from the current page of the measurement results by each pressing.
 - Scroll Down** - Moves one line downward from the current page of the measurement results by each pressing.
 - First Page** - Moves from the current page to the first page of the measurement results.
 - Last Page** - Moves from the current page to the last page of the measurement results.
- If **View/Trace** is set to **Demod Bits**, the **Print Setup** key accesses the additional menu to allow the following control to print the measurement results:
 - Print Demod** - Allows you to toggle the selection of the output types between **Screen** and **Report**. If set to **Screen**, the screen image is printed. If set to **Report**, all of the I/Q demodulated bit stream data with slot numbers is printed in text format.

- While the **Power Graph & Metrics** view is selected, the **SPAN X Scale** and **AMPLITUDE Y Scale** keys access the menus to allow the following settings:
 - The **SPAN X Scale** key accesses the following menu:
 - Scale/Div** - Allows you to set the horizontal scale by changing a spread code value. The range is 64.00 to 512.0 spread codes. The default setting is 512.0 spread codes.
 - Ref Value** - Allows you to set the spread code reference value. The range is 0.000 to 448.0 spread codes with the scale at least 64 spread codes. The default setting is 0.000 spread code.
 - Ref Position** - Allows you to set the reference position to either **Left**, **Ctr** (center) or **Right**. The default setting is **Left**.
 - Expand** - Allows you to toggle the expanding function of the code domain power graph between **On** and **Off**. If set to **On**, the CDP graph is expanded horizontally to show 64 spread codes centered at the scale or the marker position. Upon toggling back to **Off**, the spread code range returns to the previous setting.
 - The **AMPLITUDE Y Scale** key accesses the following menu:
 - Scale/Div** - Allows you to set the vertical scale by changing the value per division. The range is 0.10 to 20.0 dB per division. The default setting is 10.00 dB.
 - Ref Value** - Allows you to set the reference value ranging from -250.00 to 250.00 dB. The default setting is 0.00 dB.
- While the **I/Q Error (Quad View)** view is selected, the **SPAN X Scale** and **AMPLITUDE Y Scale** keys access the menus to allow the following settings depending on the active window.
 - If either **EVM**, **Phase Error**, or **Mag Error** window is active, the **SPAN X Scale** key accesses the following menu:
 - Scale/Div** - Allows you to set the horizontal scale by changing a symbol value per division. The range is 0.100 to 100.0 symbols per division. The default setting is 0.900 symbols, however, since **Scale Coupling** is defaulted to **On**, this value is automatically determined by the measurement result.
 - Ref Value** - Allows you to set the symbol reference value ranging from 0.00 to 1000.0 symbols. The default setting is 0.00 symbol, however, since **Scale Coupling** is defaulted to **On**, this value is automatically determined by the measurement results.

Ref Position - Allows you to set the reference position to either **Left**, **Ctr** (center) or **Right**. The default setting is **Left**.

Scale Coupling - Allows you to toggle the scale coupling function between **On** and **Off**. The default setting is **On**. Upon pressing the **Restart** front-panel key or **Restart** softkey under the **Meas Control** menu, this function automatically determines the scale per division and reference values by the measurement results.

- If either **EVM** or **Mag Error** window is active, the **AMPLITUDE Y Scale** key accesses the following menu:

Scale/Div - Allows you to set the vertical scale by changing the value per division. The range is 0.100 to 50.0% per division. The default setting is 5.00%, however, since **Scale Coupling** is defaulted to **On**, this value is automatically determined by the measurement result.

Ref Value - Allows you to set the reference value ranging from -500.00 to 500.0%. The default setting is 0.00%, however, since **Scale Coupling** is defaulted to **On**, this value is automatically determined by the measurement results.

Ref Position - Allows you to set the reference position to either **Top**, **Ctr** (center) or **Bot** (bottom). For the **EVM** graph, the default setting is **Bot**. For the **Mag Error** graph, the default setting is **Ctr**.

Scale Coupling - Allows you to toggle the scale coupling function between **On** and **Off**. The default setting is **On**. Upon pressing the **Restart** front-panel key or **Restart** softkey under the **Meas Control** menu, this function automatically determines the scale per division and reference values by the measurement results.

- If the **Phase Error** window is active, the **AMPLITUDE Y Scale** key accesses the following menu:

Scale/Div - Allows you to set the vertical scale by changing the value per division. The range is 0.0100 to 3600.0 degrees. The default setting is 5.00 degrees, however, since **Scale Coupling** is defaulted to **On**, this value is automatically determined by the measurement result.

Ref Value - Allows you to set the reference value ranging from -36000.0 to 36000.0 degrees. The default setting is 0.00 degrees, however, since **Scale Coupling** is defaulted to **On**, this value is automatically determined by the measurement results.

Ref Position - Allows you to set the reference position to either **Top**, **Ctr** (center) or **Bot** (bottom). The default setting is **Ctr**.

Scale Coupling - Allows you to toggle the scale coupling function between **On** and **Off**. The default setting is **On**. Upon pressing the **Restart** front-panel key or **Restart** softkey under the **Meas Control** menu, this function automatically determines the scale per division and reference values by the measurement results.

- While the **Code Domain (Quad View)** or **Demod Bits** view is selected, the **SPAN X Scale** and **AMPLITUDE Y Scale** keys access the menus to allow the following settings depending on the active window.

— If the **Code Domain Power** window is active, the **SPAN X Scale** key accesses the following menu:

Scale/Div - Allows you to set the horizontal scale by changing a spread code value. The range is 64.00 to 512.0 spread codes. The default setting is 512.0 spread codes.

Ref Value - Allows you to set the spread code reference value. The range is 0.000 to 448.0 spread codes with the scale at least 64 spread codes. The default setting is 0.000 spread code.

Ref Position - Allows you to set the reference position to either **Left**, **Ctr** (center) or **Right**. The default setting is **Left**.

Expand - Allows you to toggle the expanding function of the code domain power graph between **On** and **Off**. If set to **On**, the CDP graph is expanded horizontally to show 64 spread codes centered at the scale or the marker position. Upon toggling back to **Off**, the spread code range returns to the previous setting.

— If **Symbol Power** window is active, the **SPAN X Scale** key accesses the following menu:

Scale/Div - Allows you to set the horizontal scale by changing a symbol value per division. The range is 1.000 to 100.0 symbols per division with 0.01 symbol resolution. The default setting is 30.99 symbols, however, since **Scale Coupling** is defaulted to **On**, this value is automatically determined by the measurement result.

Ref Value - Allows you to set the symbol reference value ranging from 0.000 to 1000.0 symbols. The default setting is 0.000 symbol, however, since **Scale Coupling** is defaulted to **On**, this value is automatically determined by the measurement results.

Ref Position - Allows you to set the reference position to either **Left**, **Ctr** (center) or **Right**. The default setting is **Left**.

Scale Coupling - Allows you to toggle the scale coupling function between **On** and **Off**. The default setting is **On**. Upon pressing the **Restart** front-panel key or **Restart** softkey under the **Meas Control** menu, this function automatically determines the scale per division and reference values by the measurement results.

- If Code Domain Power window is active, the **AMPLITUDE Y Scale** key accesses the following menu:

Scale/Div - Allows you to set the vertical scale by changing the value per division. The range is 0.10 to 20.0 dB per division. The default setting is 10.00 dB.

Ref Value - Allows you to set the reference value ranging from -250.00 to 250.00 dB. The default setting is 0.00 dB.

- If the Symbol Power window is active, the **AMPLITUDE Y Scale** key accesses the following menu:

Scale/Div - Allows you to set the vertical scale by changing the value per division. The range is 0.10 to 20.00 dB. The default setting is 5.00 dB, however, since **Scale Coupling** is defaulted to **On**, this value is automatically determined by the measurement result.

Ref Value - Allows you to set the reference value ranging from -250.00 to 250.00 dB. The default setting is 0.00 dB, however, since **Scale Coupling** is defaulted to **On**, this value is automatically determined by the measurement results.

Ref Position - Allows you to set the reference position to either **Top**, **Ctr** (center) or **Bot** (bottom). The default setting is **Ctr**.

Scale Coupling - Allows you to toggle the scale coupling function between **On** and **Off**. The default setting is **On**. Upon pressing the **Restart** front-panel key or **Restart** softkey under the **Meas Control** menu, this function automatically determines the scale per division and reference values by the measurement results.

Using the Markers

The **Marker** front-panel key accesses the menu to configure the markers depending on the display selected.

- **Select** - Allows you to activate up to four markers with the corresponding numbers, respectively. The selected number is underlined and its function is defined by pressing the **Function** key. The default setting is 1.
- **Normal** - Allows you to activate the selected marker to read the power level and symbol code with the code layer of the marker position, for example, which is controlled by the RPG knob.
- **Delta** - Allows you to read the differences in the power levels and symbols codes between the selected marker and the next.
- **Function** - Allows you to set the selected marker function to **Band Power**, **Noise**, or **Off**. The default setting is **Off**. The **Band Power** and **Noise** functions are not available for this measurement.
- **Trace** - Allows you to place the selected marker on the **Code Domain Power**, **Symbol Power**, **Chip Power**, **EVM**, **Phase Error**, or **Mag Error** trace. The default setting is **Code Domain Power**.
- **Off** - Allows you to turn off the selected marker.
- **Shape** - Allows you to access the menu to set the selected marker shape to **Diamond**, **Line**, **Square**, or **Cross**. The default setting is **Diamond**.
- **Marker All Off** - Allows you to turn off all of the markers.
- **Mkr→Despread** - While a marker is set on any active spread channel of the code domain power graph in **Code Domain (Quad View)**, allows you to observe the **Symbol Power** and the **Symbol EVM Polar Vector** graphs with the spread code number for that active channel in other graph windows. The symbol EVM polar vector graph is displayed for the symbol power specified by the measurement interval and measurement offset.

Using the Print Function

In addition to the normal menu of the **Print Setup** front-panel key, one selection key is added to configure the print function if **View/Trace** is set to **Demod Bits**.

- **Print Demod** - Allows you to toggle the print function between **Screen** and **Report**. The default setting is **Screen**.

Troubleshooting Hints

Uncorrelated interference may cause CW interference like local oscillator feedthrough or spurs. Another uncorrelated noise may be due to I/Q modulation impairments. Correlated impairments can be due to the phase noise on the local oscillator in the upconverter or I/Q modulator of the UUT. These will be analyzed by the code domain measurements along with the QPSK EVM measurements and others.

A poor phase error indicates a problem at the I/Q baseband generator, filters, and/or modulator in the transmitter circuitry of the UUT. The output amplifier in the transmitter can also create distortion that causes unacceptably high phase error. In a real system, a poor phase error will reduce the ability of a receiver to correctly demodulate the received signal, especially in marginal signal conditions.

Making the Modulation Accuracy (Composite EVM) Measurement

Purpose

In addition to the QPSK EVM and symbol EVM measurements, the composite EVM measurement is made to qualify a transmitter. The QPSK EVM does not take into account the coding states and the symbol EVM is for measuring the symbol power against the despread symbol. The composite EVM measurement is a modulation accuracy against the multi coded reference symbol power through the spreading and scrambling circuits. Rho is one of the key modulation quality metrics, along with EVM and code domain power. Rho is the ratio of the correlated power in a multi coded channel to the total signal power. This measurement takes into account all possible error mechanisms in the entire transmission chain including baseband filtering, I/Q modulation anomalies, filter amplitude and phase non-linearities, and power amplifier distortions. This provides an overall indication of the performance level of the transmitter of the UUT.

Measurement Method

This procedure is to measure the performance of the transmitter's modulation circuitry. In a digitally modulated signal, it is possible to predict, based on the transmitted data sequence, what the ideal magnitude and phase of the carrier should be at any time.

The modulation accuracy is a measure of the difference, which is called the error vector, between the measured signal and the theoretical modulated signal. For MS measurements, the measured signal is the input signal to the HPSK de-scrambling circuit. The theoretical modulated signal is the reference signal which is the demodulated symbol power reconstructed through the spreading and scrambling circuits. The difference between these two vectors is sampled and processed using DSP.

This modulation accuracy measurement is made to get results for a composite error vector magnitude, rho, and code domain error from this difference. The code domain error is computed by projecting the error vector power onto the code domain at the maximum spreading factor. The error vector for each power code is defined as the ratio to the mean power of the reference waveform expressed in dB. Rho values are in the range of 0 to 1. A value of 1 indicates perfect correlation to the reference (high modulation quality).

If the error code 503 “Can not correlate to input signal” is shown, it means that your measurement has failed to find any active channels due to the uncorrelation with the input signal. The input signal level and/or scramble code, for example, need to be checked with to have a better correlation.

With the Rho measurement, the following data is provided:

- Rho - modulation quality representing the ratio of the correlated power in a multi coded channel to the total signal power
- EVM - peak and rms error vector magnitude
- Peak CDE - peak code domain error with a code number
- Peak Active CDE - peak active code domain error with a code number
- Magnitude Error - rms magnitude error
- Phase Error - rms phase error
- Freq Error - the frequency difference between the transmitter's actual center frequency and the frequency (or channel) that you entered
- I/Q Origin Offset - the origin offset for I/Q signals
- Active Channels - the number of active channels

Making the Measurement

NOTE

The factory default settings provide a good starting point. For special requirements, you may need to change some of the settings. Press **Meas Setup, More (1 of 2), Restore Meas Defaults** at any time to return all parameters for the current measurement to their default settings.

Select the desired center frequency as described in [“Changing the Frequency Channel” on page 23](#).

Press **MEASURE, Mod Accuracy (Composite EVM)** to immediately make a modulation accuracy measurement.

To change any of the measurement parameters from the factory default values, refer to [“Changing the Measurement Setup” on page 127](#).

Results

The next figure shows an example result of I/Q Measured Polar Vector for the modulation accuracy measurements in the graph window. The measured values for EVM, Rho, peak code domain error, magnitude error, phase error, and other parameters are shown in the text window.

Figure 3-14

Modulation Accuracy Measurement - Polar Vector View

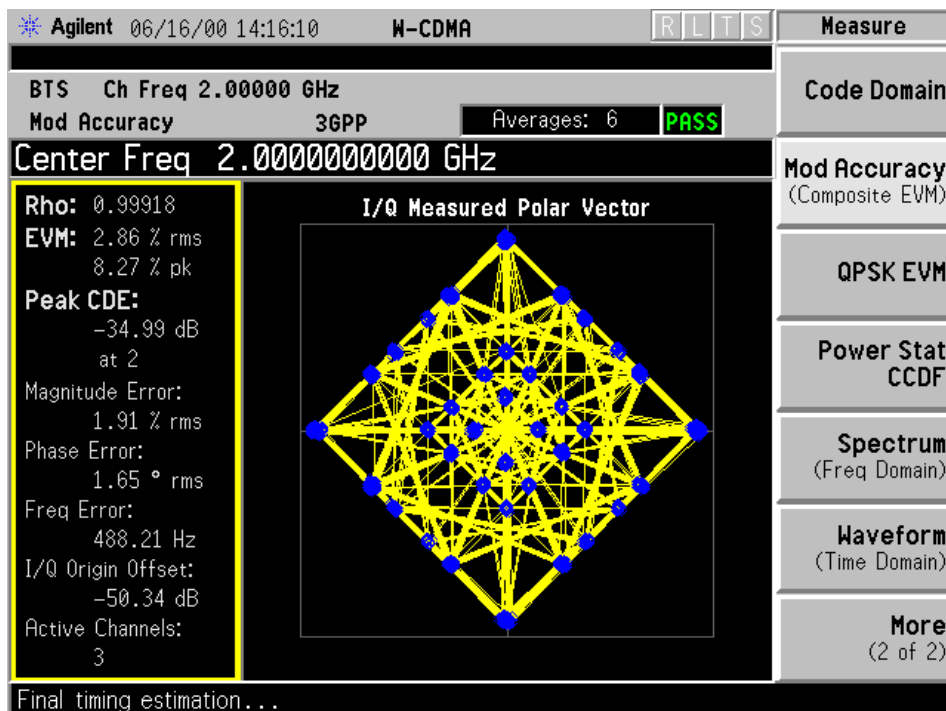

Changing the Measurement Setup

The next table shows the factory default settings for modulation accuracy (composite EVM) measurements.

Table 3-12 Modulation Accuracy (Composite EVM) Measurement Defaults

Measurement Parameter	Factory Default Condition
View/Trace	I/Q Measured Polar Vector
Meas Setup:	
Avg Number	10, On
Avg Mode	Repeat
Limits	RMS EVM (Composite) 50.00%
Trig Source	Free Run (Immediate)
Sync Type	CPICH.
P-Scramble Code	0
Scramble Code Type	Std (standard)
Scramble Code Offset	0
Spectrum	Normal
Advanced	
Alpha	0.220
Chip Rate	3.84000 MHz
Multi Channel Estimator	Off

Make sure the **Mod Accuracy (Composite EVM)** measurement is selected under the **MEASURE** menu. Press the **Meas Setup** key to access the menus which allow you to modify the average number, average mode, and trigger source as described in [“Measurement Setup” on page 58](#). Since the rho is always calculated from the whole Perch slot with 2304 chips excepting the search code symbol, there is no need to set the measurement interval in this measurement.

In addition, the following parameters can be changed according to your measurement requirement:

- **Limits** - Allows you to access the menu to activate one of the following limits to enter a new limit value:
 - RMS EVM (Composite)** - Allows you to set the limit for composite RMS EVM measurement result. The range is 0.10 to 50.00%.

Peak EVM (Composite) - Allows you to set the limit for composite peak EVM measurement result. The range is 0.10 to 100.00%. The default is 100.0%.

Rho (Composite) - Allows you to set the limit for composite Rho measurement result. The range is 0.00100 to 1.00000.

Peak Code Domain Error - Allows you to set the limit for composite peak code domain error measurement result. The range is -100.0 to 0.0 dB.

- **Sync Type** - Allows you to access the following menu to select one channel to be synchronized with if **Device** is set to **BTS**:

CPICH - CPICH channel is set to synchronize with.

SCH - SCH channel is set to synchronize with.

If **Device** is set to **MS**, **DPCCH** is automatically set.

- **P-Scramble Code** - If **Device** is set to **BTS**, allows you to enter a numeric value for the primary scramble code. The range is 0 to 511.

If **Device** is set to **MS**, this label changes to **Scramble Code**, and allows you to enter a hexadecimal value for the scramble code. Pressing this key reveals the keys labeled **A** to **F** and **Done**. The range is 0000 to FFFFFFFF. Use the numeric keypad and these keys to enter a hexadecimal value by terminating with the **Done** key.

- **Scramble Code Type** - Allows you to set the scramble code type to either **Std** (standard), **Left**, or **Right** to make the modulation accuracy measurement. This key is not available if **Device** is set to **MS**.
- **Scramble Code Offset** - Allows you to set the number of scramble code offsets to make the modulation accuracy measurement. The range is 0 to 15. This key is not available if **Device** is set to **MS**.
- **Spectrum** - Allows you to toggle the spectrum function between **Normal** and **Invert**. This key, when set to **Invert**, conjugates the spectrum, which equivalently negates the quadrature component in demodulation. The correct setting (**Normal** or **Invert**) depends on whether the signal being given to the transmitter tester has a high or low side mix.
- **Advanced** - Allows you to access the menu to change the following parameters:

Alpha - Allows you to change the alpha value of the root-raised cosine filter. The range is 0.01 to 0.50.

Chip Rate - Allows you to change the chip rate ranging from 3.45600 to 4.22400 MHz.

Multi Channel Estimator - Allows you to toggle the multi channel estimator function between **On** and **Off**. If set to **On**, the multi channel estimator makes a computation to improve the phase error whether each code phase is aligned or not, but takes a longer time. If set to **Off**, each code phase needs to be aligned and the phase information is computed from one coded signal only.

Changing the View

The **View/Trace** key will allow you to select the desired measurement view from the following selections:

- **I/Q Measured Polar Vector** - Provides a combination view of an I/Q measured polar vector graph and the summary data as shown in [Figure 3-14 on page 126](#).
- **I/Q Measured Polar Constln** - Provides a combination view of an I/Q measured polar constellation graph in the graph window and the measured values for Rho, EVM, magnitude error, phase error, and other parameters in the text window as shown below:

Figure 3-15 Modulation Accuracy Measurement - Polar Constellation View

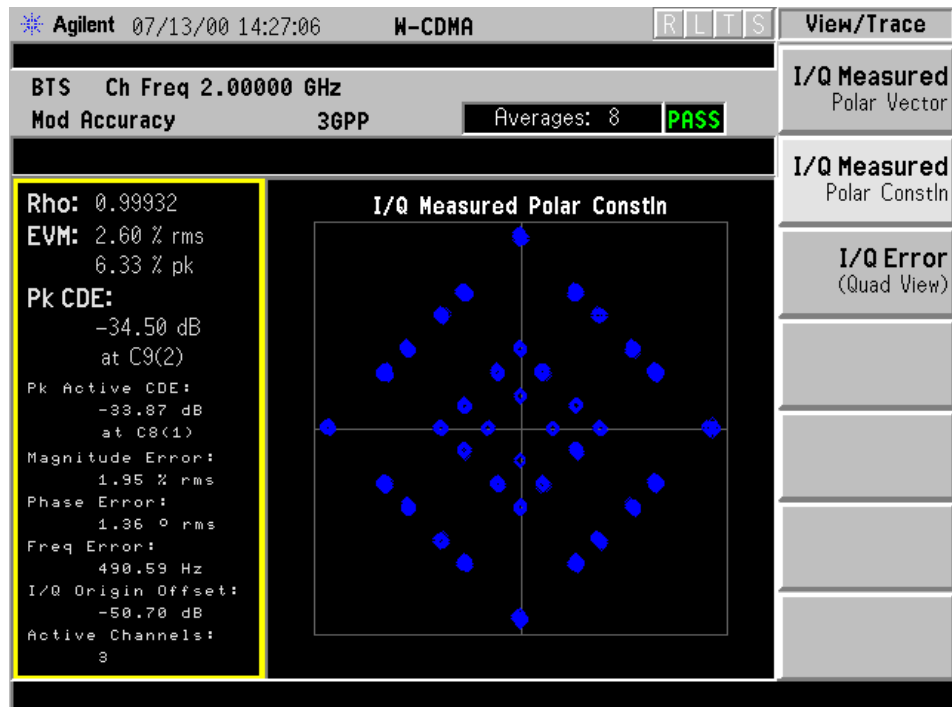

- **I/Q Error (Quad View)** - Provides a combination view of a magnitude error, phase error, EVM graphs, and the modulation accuracy summary data such as rms rho, peak and rms EVM, magnitude error, phase error, and so forth in the text window as shown below:

Figure 3-16 Modulation Accuracy Measurement - I/Q Error Quad View

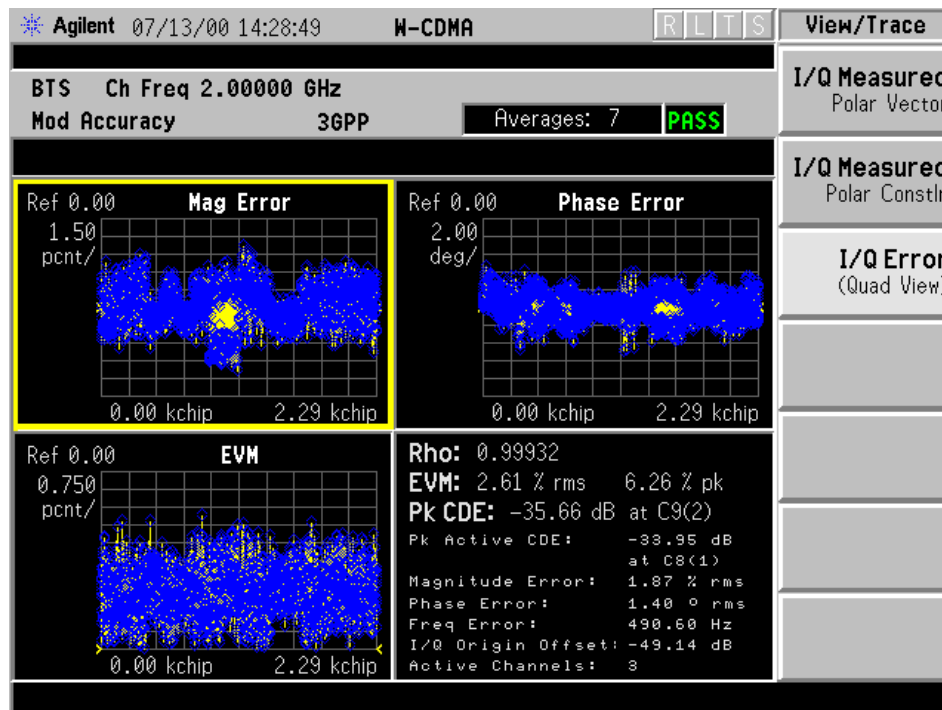

Any one of these windows can be selected by the **Next Window** key and made full size by the **Zoom** key.

Changing the Display

The **Display** key accesses the menu to allow the following selections for changing the graph displays of I/Q Measured Polar Vector, I/Q Measured Polar Constellation, and I/Q Error (Quad View):

- **I/Q Points** - Allows you to specify the number of displayed points for the I/Q waveforms. The range is 1 to 2304 (2560 × 0.9) points with the points per chip fixed to 1. The default setting is 2304 points.
- **Chip Dots** - Allows you to toggle the chip dot display between **On** and **Off**. The default setting is **On**.
- **+45 deg Rot** - Allows you to toggle the display rotation function between **On** and **Off**. If this is set to **On**, the I/Q polar vector or I/Q polar constellation graph is rotated by +45 degrees to see a rectangular display. The default setting is **Off**.

When either **EVM**, **Phase Error**, or **Mag Error** window is active in the **I/Q Error (Quad View)** display, the **SPAN X Scale** key accesses the menu to allow the following settings:

- **Scale/Div** - Allows you to set the horizontal scale by changing a chip value per division. The range is 1.000 to 256.00 chips per division with 0.001 chip resolution. The default setting is 230.30 chips per division, however, since **Scale Coupling** is defaulted to **On**, this value is automatically determined by the measurement results.
- **Ref Value** - Allows you to set the chip reference value ranging from 0.000 to 2560.0 chips. The default setting is 0.000 chip, however, since **Scale Coupling** is defaulted to **On**, this value is automatically determined by the measurement results.
- **Ref Position** - Allows you to set the reference position to either **Left**, **Ctr** (center) or **Right**. The default setting is **Left**.
- **Scale Coupling** - Allows you to toggle the scale coupling function between **On** and **Off**. The default setting is **On**. Upon pressing the **Restart** front-panel key or **Restart** softkey under the **Meas Control** menu, this function automatically determines the scale per division and reference values by the measurement results.

When either **EVM** or **Mag Error** window is active in the **I/Q Error (Quad View)** display, the **AMPLITUDE Y Scale** key accesses the menu to allow the following settings:

- **Scale/Div** - Allows you to set the vertical scale by changing the value per division. The range is 0.100 to 50.0% per division. The default setting is 5.00%, however, since **Scale Coupling** is defaulted to **On**, this value is automatically determined by the measurement result.
- **Ref Value** - Allows you to set the reference value ranging from 0.00 to 500.0%. The default setting is 0.00%, however, since **Scale Coupling** is defaulted to **On**, this value is automatically determined by the measurement results.
- **Ref Position** - Allows you to set the reference position to either **Top**, **Ctr** (center) or **Bot** (bottom). For the **EVM** graph, the default setting is **Bot**. For the **Mag Error** graph, the default setting is **Ctr**.
- **Scale Coupling** - Allows you to toggle the scale coupling function between **On** and **Off**. The default setting is **On**. Upon pressing the **Restart** front-panel key or **Restart** softkey under the **Meas Control** menu, this function automatically determines the scale per division and reference values by the measurement results.

When the `Phase Error` window is active in the `I/Q Error (Quad View)` display, the `AMPLITUDE Y Scale` key accesses the menu to allow the following settings:

- **Scale/Div** - Allows you to set the vertical scale by changing the value per division. The range is 0.01 to 3600 degrees. The default setting is 5.00 degrees per division, however, since **Scale Coupling** is defaulted to **On**, this value is automatically determined by the measurement results.
- **Ref Value** - Allows you to set the reference value ranging from -36000 to 36000 degrees. The default setting is 0.00 degrees, however, since **Scale Coupling** is defaulted to **On**, this value is automatically determined by the measurement results.
- **Ref Position** - Allows you to set the reference position to either **Top**, **Ctr** (center) or **Bot** (bottom). The default setting is **Ctr**.
- **Scale Coupling** - Allows you to toggle the scale coupling function between **On** and **Off**. The default setting is **On**. Upon pressing the **Restart** front-panel key or **Restart** softkey under the **Meas Control** menu, this function automatically determines the scale per division and reference values by the measurement results.

Using the Markers

The **Marker** front-panel key accesses the menu to configure the markers depending on the display selected.

- **Select** - Allows you to activate up to four markers with the corresponding numbers, respectively. The selected number is underlined and its function is defined by pressing the **Function** key. The default setting is 1.
- **Normal** - Allows you to activate the selected marker to read the magnitude or phase error and the number of chips of the marker position on the selected trace, for example, which is controlled by the **RPG** knob.
- **Delta** - Allows you to read the differences in the magnitude or phase errors and the number of chips between the selected marker and the next.
- **Function** - Allows you to set the selected marker function to **Band Power**, **Noise**, or **Off**. The default setting is **Off**. The **Band Power** and **Noise** functions are not available for this measurement.
- **Trace** - Allows you to place the selected marker on the **EVM**, **Phase Error**, or **Mag Error** trace. The default setting is **EVM**.
- **Off** - Allows you to turn off the selected marker.
- **Shape** - Allows you to access the menu to set the selected marker shape to **Diamond**, **Line**, **Square**, or **Cross**. The default setting is **Diamond**.
- **Marker All Off** - Allows you to turn off all of the markers.

Troubleshooting Hints

A poor phase error often indicates a problem at the I/Q baseband generator, filters, and/or modulator in the transmitter circuitry of the UUT. The output amplifier in the transmitter can also create distortion that causes unacceptably high phase error. In a real system, a poor phase error will reduce the ability of a receiver to correctly demodulate the received signal, especially in marginal signal conditions.

Making the QPSK EVM Measurement

Purpose

Phase and frequency errors of the single coded signal are measures of modulation quality for the W-CDMA (3GPP) system. This modulation quality is quantified through QPSK Error Vector Magnitude (EVM) measurements. Since the W-CDMA (3GPP) system uses the Quadrature Phase Shift Keying (QPSK) modulation technique, the phase and frequency accuracies of the transmitter are critical to the communications system performance and ultimately affect range.

W-CDMA (3GPP) receivers rely on the phase and frequency quality of the QPSK modulation signal in order to achieve the expected carrier to noise ratio. A transmitter with high phase and frequency errors will often still be able to support phone calls during a functional test. However, it will tend to provide difficulty for mobiles trying to maintain service at the edge of the cell with low signal levels or under difficult fading and Doppler conditions.

Measurement Method

The phase error of the unit under test is measured by computing the difference between the phase of the transmitted signal and the phase of a theoretically perfect signal.

The instrument samples the transmitter output in order to capture the actual phase trajectory. This is then demodulated and the ideal phase trajectory is mathematically derived using detected bits and root-raised cosine channel filtering. Subtracting one from the other results in a phase error signal.

This measurement allows you to display these errors numerically and graphically on the instrument display. There are graphs for I/Q Measured Polar Vector, I/Q Measured Polar Constellation, EVM, Phase Error and Mag Error in the graph windows. In the text window, there are both maximum and average data for Evm: in % rms, in % peak, RMS Mag Error: in %, Phase Error: in degrees, Freq Error: in Hz, and IQ Origin Offset: in dB.

Making the Measurement

NOTE The factory default settings provide a good starting point. For special requirements, you may need to change some of the settings. Press **Meas Setup, More (1 of 2), Restore Meas Defaults** at any time to return all parameters for the current measurement to their default settings.

Select the desired center frequency as described in [“Changing the Frequency Channel” on page 23](#).

Press **MEASURE, QPSK EVM** to immediately make a QPSK error vector magnitude (EVM) measurement.

To change any of the measurement parameters from the factory default values, refer to [“Changing the Measurement Setup” on page 136](#).

Results

The next figure shows an example result of I/Q Measured Polar Vector for the QPSK EVM measurements in the graph window. The measured values for EVM and other parameters are shown in the text window.

Figure 3-17 QPSK EVM Measurement - Polar Vector View

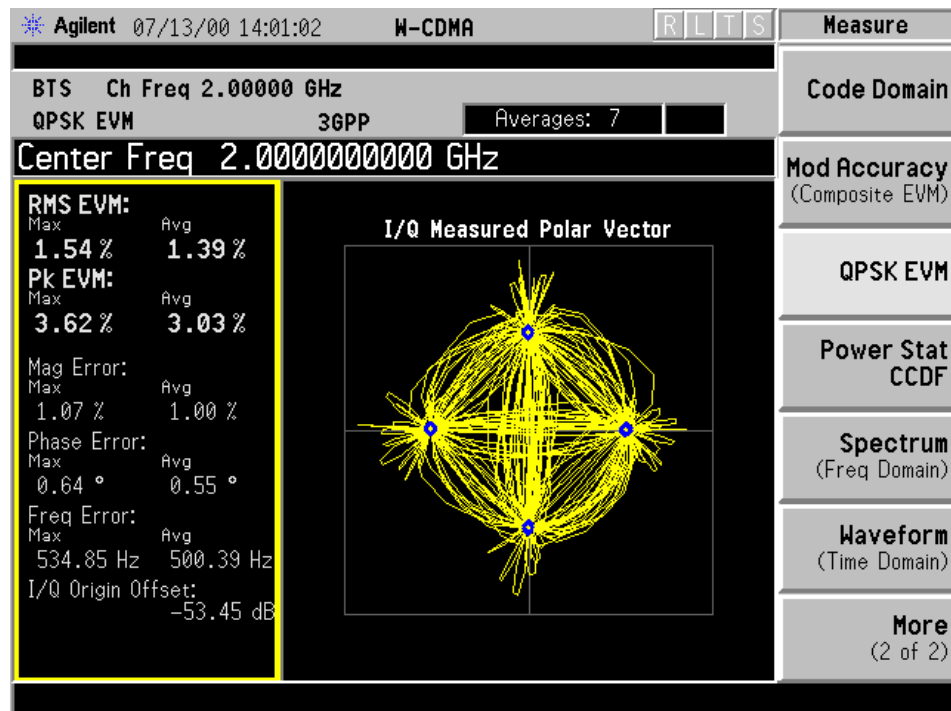

Changing the Measurement Setup

The next table shows the factory default settings for QPSK EVM measurements.

Table 3-13 QPSK EVM Measurement Defaults

Measurement Parameter	Factory Default Condition
View/Trace	I/Q Measured Polar Vector
Meas Setup:	
Avg Number	10, On
Avg Mode	Repeat
Meas Interval	256 chips
Trig Source	Free Run (Immediate)
Advanced	
Alpha	0.220
Chip Rate	3.84000 MHz

Make sure the **QPSK EVM** measurement is selected under the **MEASURE** menu. Press the **Meas Setup** key to access the menu which allows you to modify the average number, average mode, and trigger source as described in “[Measurement Setup](#)” on page 58.

In addition, the following parameters can be changed according to your measurement requirement:

- **Meas Interval** - Allows you to set the time interval over which the measurement is made. The range is 128 to 512 chips.
- **Advanced** - Allows you to access the menu to change the following parameters:
 - Alpha** - Allows you to change the alpha value of the root-raised cosine filter. The range is 0.01 to 0.50.
 - Chip Rate** - Allows you to change the chip rate. The range is 3.45600 to 4.22400 MHz.

Changing the View

The **View/Trace** key will allow you to select the desired view of the measurement from the following:

- **I/Q Measured Polar Vector** - Provides a combination view of an I/Q measured polar vector graph and the maximum and average summary data as shown in [Figure 3-17 on page 135](#).
- **I/Q Measured Polar Constln** - Provides a combination view of an I/Q measured polar constellation graph and the maximum and average summary data as shown below.

Figure 3-18 QPSK EVM Measurement - Polar Constellation View

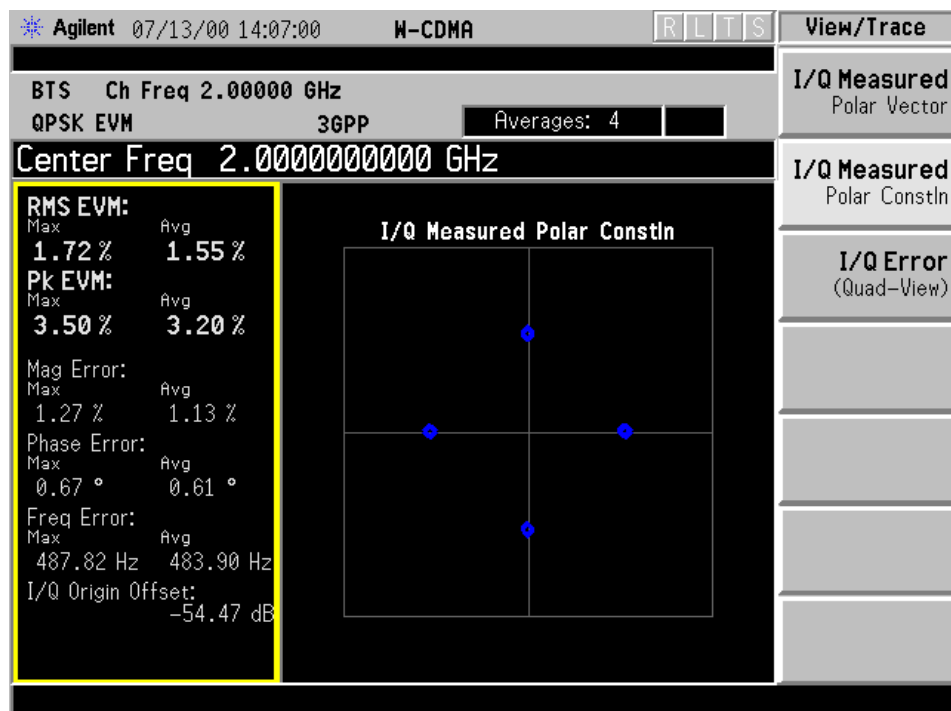

- **I/Q Error (Quad View)** - Four display windows show Mag Error, Phase Error and EVM graphs and the maximum and average EVM summary data in the text window as shown below.

Figure 3-19 QPSK EVM Measurement - I/Q Error Quad View

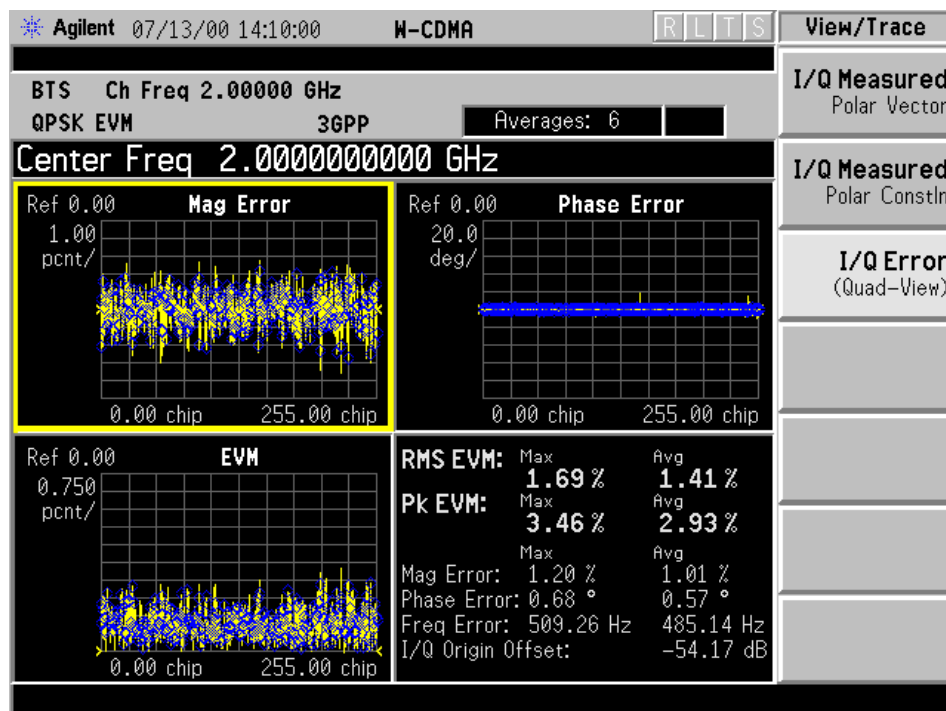

Any of these windows can be selected using the **Next Window** key and made full size using the **Zoom** key.

Changing the Display

The **Display** key accesses the menu to allow the following selections for changing the graph displays of I/Q Measured Polar Vector, I/Q Measured Polar Constellation and I/Q Error (Quad View):

- **I/Q Points** - Allows you to specify the number of displayed chips for the I/Q waveforms. The range is 1 to 640 points with the points per chip fixed to 5, depending on the **Meas Interval** setting. The default setting is 640 points.
- **Chip Dots** - Allows you to toggle the chip dot display between **On** and **Off**. The default setting is **On**.
- **+45 deg Rot** - Allows you to toggle the display rotation function between **On** and **Off**. If this is set to **On**, the I/Q polar vector or I/Q polar constellation graph is rotated by +45 degrees to see a rectangular display. The default setting is **Off**.

When either **EVM**, **Phase Error**, or **Mag Error** window is active in the **I/Q Error (Quad View)** display, the **SPAN X Scale** key accesses the menu to allow the following settings:

- **Scale/Div** - Allows you to set the horizontal scale by changing a chip value per division. The range is 1.00 to 512.00 chips per division with 0.01 chip resolution. The default setting is 25.50 chips per division, however, since **Scale Coupling** is defaulted to **On**, this value is automatically determined by the measurement result.
- **Ref Value** - Allows you to set the chip reference value ranging from 0.000 to 1000.0 chips. The default setting is 0.000 chip, however, since **Scale Coupling** is defaulted to **On**, this value is automatically determined by the measurement results.
- **Ref Position** - Allows you to set the reference position to either **Left**, **Ctr** (center) or **Right**. The default setting is **Left**.
- **Scale Coupling** - Allows you to toggle the scale coupling function between **On** and **Off**. The default setting is **On**. Upon pressing the **Restart** front-panel key or **Restart** softkey under the **Meas Control** menu, this function automatically determines the scale per division and reference values by the measurement results.

When either **EVM** or **Mag Error** window is active in the **I/Q Error (Quad View)** display, the **AMPLITUDE Y Scale** key accesses the menu to allow the following settings:

- **Scale/Div** - Allows you to set the vertical scale by changing the value per division. The range is 0.100 to 50.0% per division. The default setting is 5.00%, however, since **Scale Coupling** is defaulted to **On**, this value is automatically determined by the measurement result.
- **Ref Value** - Allows you to set the reference value ranging from -500.0 to 500.0%. The default setting is 0.00%, however, since **Scale Coupling** is defaulted to **On**, this value is automatically determined by the measurement results.
- **Ref Position** - Allows you to set the reference position to either **Top**, **Ctr** (center) or **Bot** (bottom). For the **EVM** graph, the default setting is **Bot**. For the **Mag Error** graph, the default setting is **Ctr**.
- **Scale Coupling** - Allows you to toggle the scale coupling function between **On** and **Off**. The default setting is **On**. Upon pressing the **Restart** front-panel key or **Restart** softkey under the **Meas Control** menu, this function automatically determines the scale per division and reference values by the measurement results.

When the **Phase Error** window is active in the **I/Q Error (Quad View)** display, the **AMPLITUDE Y Scale** key accesses the menu to allow the following settings:

- **Scale/Div** - Allows you to set the vertical scale by changing the value per division. The range is 0.01 to 3600 degrees. The default setting is 5.00 degrees per division, however, since **Scale Coupling** is defaulted to **On**, this value is automatically determined by the measurement result.
- **Ref Value** - Allows you to set the reference value ranging from -36000 to 36000 degrees. The default setting is 0.00 degrees, however, since **Scale Coupling** is defaulted to **On**, this value is automatically determined by the measurement results.
- **Ref Position** - Allows you to set the reference position to either **Top**, **Ctr** (center) or **Bot** (bottom). The default setting is **Ctr**.
- **Scale Coupling** - Allows you to toggle the scale coupling function between **On** and **Off**. The default setting is **On**. Upon pressing the **Restart** front-panel key or **Restart** softkey under the **Meas Control** menu, this function automatically determines the scale per division and reference values by the measurement results.

Using the Markers

The **Marker** front-panel key accesses the menu to configure the markers depending on the display selected.

- **Select** - Allows you to activate up to four markers with the corresponding numbers, respectively. The selected number is underlined and its function is defined by pressing the **Function** key. The default setting is 1.
- **Normal** - Allows you to activate the selected marker to read the magnitude or phase error and the number of chips of the marker position on the selected trace, for example, which is controlled by the **RPG** knob.
- **Delta** - Allows you to read the differences in the magnitude or phase errors and the number of chips between the selected marker and the next.
- **Function** - Allows you to set the selected marker function to **Band Power**, **Noise**, or **Off**. The default setting is **Off**. The **Band Power** and **Noise** functions are not available for this measurement.
- **Trace** - Allows you to place the selected marker on the **EVM**, **Phase Error**, or **Mag Error** trace. The default setting is **EVM**.
- **Off** - Allows you to turn off the selected marker.

- **Shape** - Allows you to access the menu to set the selected marker shape to **Diamond**, **Line**, **Square**, or **Cross**. The default setting is **Diamond**.
- **Marker All Off** - Allows you to turn off all of the markers.

Troubleshooting Hints

A poor phase error indicates a problem at the I/Q baseband generator, filters, and/or modulator in the transmitter circuitry of the UUT. The output amplifier in the transmitter can also create distortion that causes unacceptably high phase error. In a real system, a poor phase error will reduce the ability of a receiver to correctly demodulate the received signal, especially in marginal signal conditions.

Making the Power Stat CCDF Measurement

Purpose

Many of the digitally modulated signals now look noise-like in the time and frequency domain. This means that statistical measurements of the signals can be a useful characterization. Power Complementary Cumulative Distribution Function (CCDF) curves characterize the higher level power statistics of a digitally modulated signal. The curves can be useful in determining design parameters for digital communications systems.

The power statistics CCDF measurement can be affected by many factors. For example, modulation filtering, modulation format, combining the multiple signals at different frequencies, number of active codes, and correlation between symbols on different codes with spread spectrum systems will all affect measurement results. These factors are all related to modulation and signal parameters. External factors such as signal compression and expansion by nonlinear components, group delay distortion from filtering, and power control within the observation interval also affect the measurement.

Measurement Method

The power measured in power statistics CCDF curves is actually instantaneous envelope power defined by the equation:

$$P = (I^2 + Q^2) / Z_0$$

(where I and Q are the quadrature voltage components of the waveform and Z_0 is the characteristic impedance).

A CCDF curve is defined by how much time the waveform spends at or above a given power level. The percent of time the signal spends at or above the level defines the probability for that particular power level. For capturing a lower probability down to 0.0001%, this measurement is made in the single mode by setting **Measure** under **Meas Control** to **Single**. To make the power statistics CCDF measurement, the transmitter tester uses digital signal processing (DSP) to sample the input signal in the channel bandwidth.

The Gaussian distribution line as the band-limited gaussian noise CCDF reference line, the user-definable reference trace, and the currently measured trace can be displayed on a semi-log graph. If the currently measured trace is above the user reference trace, it means that the higher peak power levels against the average power are included in the input signal.

Making the Measurement

NOTE

The factory default settings provide a good starting point. For special requirements, you may need to change some of the settings. Press **Meas Setup, More (1 of 2), Restore Meas Defaults** at any time to return all parameters for the current measurement to their default settings.

Select the desired center frequency as described in [“Changing the Frequency Channel” on page 23](#).

Press **MEASURE, Power Stat CCDF** to immediately make a power statistics CCDF measurement.

To change any of the measurement parameters from the factory default values, refer to [“Changing the Measurement Setup” on page 144](#).

Results

The next figure shows an example result of Power Stat CCDF measurements in the graph window. The average power and its probability are shown in the text window.

Figure 3-20

Power Statistics CCDF Measurement



Changing the Measurement Setup

The next table shows the factory default settings for power statistics CCDF measurements.

Table 3-14 Power Statistics CCDF Measurement Defaults

Measurement Parameter	Factory Default Condition
Meas Setup:	
Meas BW	5.00000 MHz
Counts	10.0000 Mpt
Meas Interval	1.000 ms
Trig Source	Free Run (Immediate)
Meas Control:	
Measure	Single
Display:	
Ref Trace	Off
Gaussian Line	On

Make sure the **Power Stat CCDF** measurement is selected under the **MEASURE** menu. Press the **Meas Setup** key to access the menu which allows you to modify the trigger source for this measurement as described in [“Measurement Setup” on page 58](#). Also, press the **Meas Control** key to access the menu which allows you to change **Measure** from **Single** to **Cont** (continuous) as described in [“Measurement Control” on page 57](#).

In addition, the following parameters can be changed according to your measurement requirement:

- **Meas BW** - Allows you to set the measurement bandwidth according to the channel bandwidth. The range is 10.000 kHz to 6.70000 MHz with 0.1 kHz resolution.
- **Counts** - Allows you to set the accumulated number of sampling points for data acquisition. The range is 1.000 kpt (k point) to 2.00000 Gpt (G point) with 1 kpt resolution. While this key is activated, enter a value from the numeric keypad by terminating with one of the unit keys shown.
- **Meas Interval** - Allows you to specify the time interval over which the measurement is made. The range is 100.0 μ s to 10.00 ms with 1 μ s resolution.

Changing the View

The **View/Trace** key is not available for this measurement.

Changing the Display

The **Display** key allows you to control the desired trace and line displays of the power statistics CCDF curves. The currently measured curve is always shown.

- **Store Ref Trace** - Allows you to copy the currently measured curve as the user-definable reference trace. The captured data will remain until the other mode is chosen. Pressing this key refreshes the reference trace.
- **Ref Trace** - Allows you to toggle the reference trace display function between **On** and **Off**.
- **Gaussian Line** - Allows you to toggle the Gaussian line display function between **On** and **Off**.

The **SPAN X Scale** key accesses the menu to set the desired horizontal scale.

- **Scale/Div** - Allows you to enter a numeric value to change the horizontal display sensitivity. The range is 0.10 to 20.00 dB with 0.01 dB resolution. The default setting is 2.00 dB.

Using the Markers

The **Marker** front-panel key accesses the menu to configure the markers.

- **Select** - Allows you to activate up to four markers with the corresponding numbers, respectively. The selected number is underlined and its function is defined by pressing the **Function** key. The default selection is 1.
- **Normal** - Allows you to activate the selected marker to read the power level and probability of the marker position on the selected curve, for example, which is controlled by the RPG knob.
- **Delta** - Allows you to read the differences in the power levels and probabilities between the selected marker and the next.
- **Function** - Allows you to set the selected marker function to **Band Power**, **Noise**, or **Off**. The default setting is **Off**. The **Band Power** and **Noise** functions are not available for this measurement.
- **Trace** - Allows you to place the selected marker on the **Measured**, **Gaussian**, or **Reference** curve. The default setting is **Measured**.
- **Off** - Allows you to turn off the selected marker.
- **Shape** - Allows you to access the menu to set the selected marker shape to **Diamond**, **Line**, **Square**, or **Cross**. The default setting is **Diamond**.
- **Marker All Off** - Allows you to turn off all of the markers.

Troubleshooting Hints

The power statistics CCDF measurement can contribute in setting the signal power specifications for design criteria for systems, amplifiers, and other components. For example, it can help determine the optimum operating point to adjust each code timing for appropriate peak/average power ratio throughout the wide channel bandwidth of the transmitter for a W-CDMA (3GPP) system.

As this measurement is a new method, there will be some correlations between CCDF curve degradation and digital radio system measurement parameters such as BER, FER, code domain power, and ACPR. Some studies will help set standards for radio design by specifying the maximum allowed CCDF curve degradation for specific systems.

Making the Spectrum (Frequency Domain) Measurement

Purpose

The spectrum measurement provides spectrum analysis capability for the instrument. The control of the measurement was designed to be familiar to those who are accustomed to using swept spectrum analyzers.

This measurement is FFT (Fast Fourier Transform) based. The FFT-specific parameters are located in the **Advanced** menu. Also available under basic mode spectrum measurements is an I/Q window, which shows the I and Q signals in parameters of voltage versus time. The advantage of having an I/Q view available while in the spectrum measurement is that it allows you to view complex components of the same signal without changing settings or measurements.

Measurement Method

The transmitter tester uses digital signal processing to sample the input signal and convert it to the frequency domain. With the instrument tuned to a fixed center frequency, samples are digitized at a high rate, converted to I and Q components with DSP hardware, and then converted to the frequency domain with FFT software.

Making the Measurement

NOTE

The factory default parameters provide a good starting point. You will likely want to change some of the settings. Press **Meas Setup, More (1 of 2), Restore Meas Defaults** at any time to return all parameters for the current measurement to their default settings.

Press **Measure, Spectrum (Freq Domain)** to immediately make Spectrum (Frequency Domain) the active measurement.

To change any of the measurement parameters from the factory default values, refer to the “Changing the Measurement Setup” section for this measurement.

Results

A display with both a spectrum window and an I/Q Waveform window will appear when you activate a spectrum measurement. Use the **Next Window** key to select a window, and the **Zoom** key to enlarge a window.

Figure 3-21 Spectrum Measurement - Spectrum and I/Q Waveform View

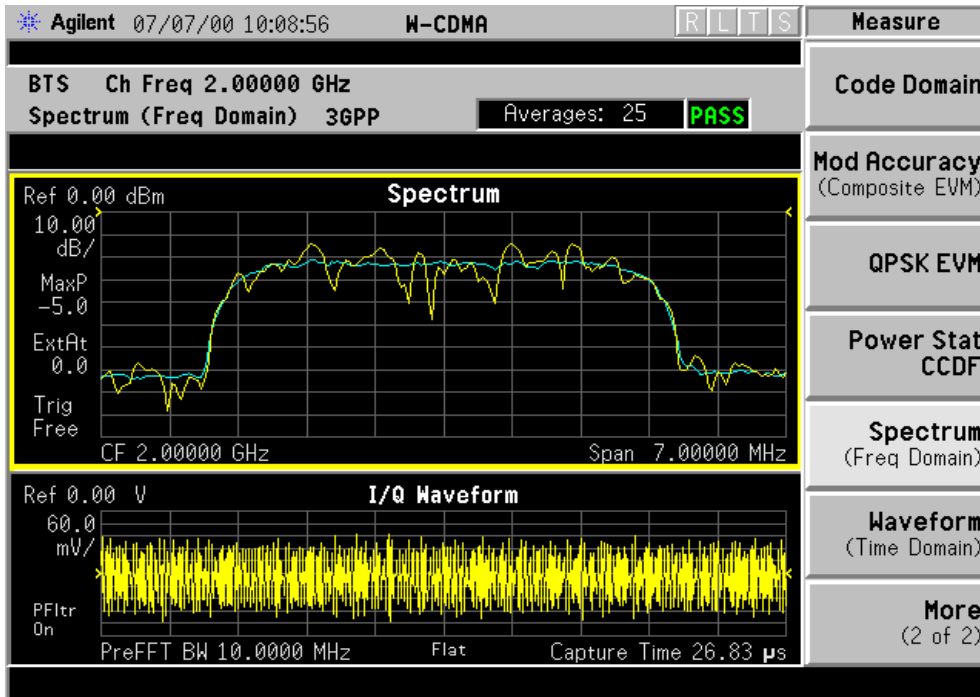
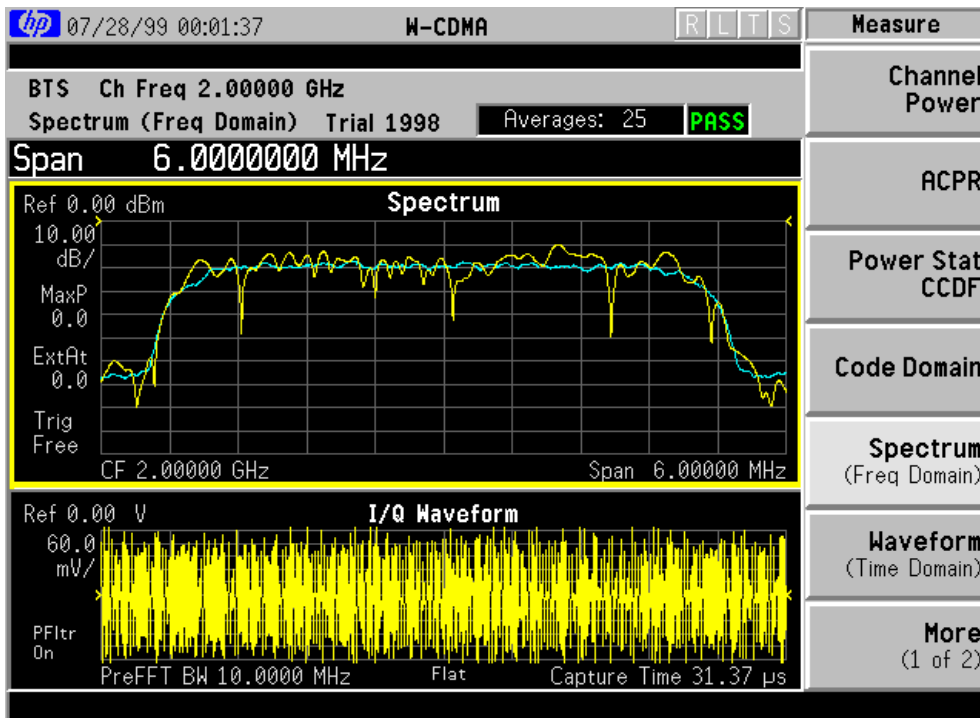

Figure 3-22 Spectrum Measurement - Spectrum and I/Q Waveform View



Changing the Measurement Setup

Table 1 **Spectrum (Frequency Domain) Measurement Defaults**

Measurement Parameter	Factory Default Condition
Res BW	20.0000 kHz (Auto)
Averaging:	
Avg Number	25 On
Avg Mode	Exp
Avg Type	Log-Pwr Avg (Video)
Trigger Source	Free Run (Immediate)
Measurement Time (Service mode only)	1.0 ms (Auto)
Spectrum Window:	
Span	1.00000 MHz
Scale/Div - Amplitude Y Scale	10.00 dB
I/Q Waveform Window:	
Capture Time	188.00 μ s
Scale/Div - Amplitude Y Scale	60 mV
Advanced	
Pre-ADC BPF	On
Pre-FFT Filter	Flat
Pre-FFT BW	1.55000 MHz (Auto)
FFT Window	Flat Top (High AmptdAcc)
FFT Size:	
Length Control	Auto
Min Points/RBW	1.300000
Window Length	706
FFT Length	4096
ADC Range	Auto Peak
Data Packing	Auto
ADC Dither	Auto
Decimation	0 (Auto)
IF Flatness	On

NOTE

Parameters under the **Advanced** key seldom need to be changed. Any changes from the default advanced values may result in invalid measurement data.

Make sure the **Spectrum (Freq Domain)** measurement is selected under the **Measure** menu. Press the **Meas Setup** key to access a menu which allows you to modify the averaging, and trigger source for this measurement (as described in the “Measurement Setup” section). In addition, the following parameters can be modified:

- **Span** - This key allows you to modify the frequency span. Changing the span causes the bandwidth to change automatically, and will affect data acquisition time.
- **Res BW** - This feature sets the resolution bandwidth for the FFT, and allows manual or automatic settings. A narrower bandwidth will result in a longer data acquisition time. In Auto mode the resolution bandwidth is set to Span/50 (2% of the span).
- **Advanced** - The following FFT advanced features should be used only if you are familiar with their operation. Changes from the default values may result in invalid data.

Pre-ADC BPF - This key allows you to toggle the pre-ADC bandpass filter to On or Off states. The pre-ADC bandpass filter is useful for rejecting nearby signals, so that sensitivity within the span range can be improved by increasing the ADC range gain.

Pre-FFT Fltr - Allows you to toggle between **Flat** (flat top) and **Gaussian**. The pre-FFT filter defaults to a flat top filter which has better amplitude accuracy. The Gaussian filter has better pulse response.

Pre-FFT BW - The Pre-FFT bandwidth allows you to select between a manual or an automatic setting. The pre FFT-bandwidth filter can be set between 1 Hz and 10 MHz. In Auto mode this bandwidth is nominally 50% wider than the span. This bandwidth determines the ADC sampling rate.

FFT Window - Allows you to access the following selection menu. Unless you are familiar with FFT windows, use the flat top filter (the default filter).

- **Flat Top** - Selects a filter for best amplitude accuracy, by reducing scalloping error.
- **Uniform** - You can select to have no window active by using the uniform setting.
- **Hanning**
- **Hamming**
- **Gaussian** - Selects a gaussian filter with an alpha of 3.5.

- **Blackman**
- **Blackman Harris**
- **K-B 70dB / 90dB/ 110dB (Kaiser-Bessel)** - Allows selection of Kaiser-Bessel filters with sidelobes of -70 , -90 , or -110 dBc.

FFT Size - This menu contains the following features:

- **Length Ctrl** - This feature allows you to set the FFT and window lengths either automatically or manually.
- **Min Pts in RBW** - This feature allows you to set the minimum number of data points that will be used inside the resolution bandwidth. This adjustment is only available if the **Length Ctrl** key is set to Auto.
- **Window Length** - This feature allows you to enter the FFT window length ranging from 8 to 1048576. This length represents the actual quantity of I/Q samples that are captured for processing by the FFT. This value can only be entered if length control is set to Manual.
- **FFT Length** - This feature allows you to enter the FFT length in the number of captured samples, ranging from 4096 to 1048576. The FFT length setting is automatically limited so that it is equal or greater than the FFT window length setting. Any amount greater than the window length is implemented by zero-padding. This value can be entered only if length control is set to Man (manual).

ADC Range - Allows you to access the following selection menu to define one of the following ADC ranging functions:

- **Auto** - Select this to set the ADC range automatically. For most FFT spectrum measurements, the auto feature should not be selected. An exception is when measuring a signal which is “bursty”, in which case auto can maximize the time domain dynamic range, if FFT results are less important to you than time domain results.
- **Auto Peak** - Select this to set the ADC range automatically to the peak signal level. Auto peak is a compromise that works well for both CW and burst signals.
- **AutoPeakLock** - Select this to hold the ADC range automatically at the peak signal level. Auto peak lock is more stable than auto peak for CW signals, but should not be used for “bursty” signals.
- **Manual** - Allows you to access the selection menu: -6 dB, 0 dB, $+6$ dB, $+12$ dB, $+18$ dB, $+24$ dB, to set the ADC range level. Also note that manual ranging is best for CW signals.

Data Packing - Allows you to access the following selection menu to define one of the following data packing methods:

- **Auto** - Data is automatically packed. This is the default setting and most recommended.
- **Short (16 bit)** - Data is packed by every 16 bits.
- **Medium (24 bit)** - Data is packed by every 24 bits.
- **Long (32 bit)** - Data is packed by every 32 bits.

ADC Dither - Allows you to toggle the ADC dither function between **Auto**, **On**, and **Off**. When set to **auto** (the default), ADC dither will be activated when a narrow bandwidth is being measured, and deactivated when a wide bandwidth is being measured. “ADC dither” refers to the introduction of noise to the digitized steps of the analog-to-digital converter; the result is an improvement in amplitude accuracy. Use of the ADC dither, however, reduces dynamic range by approximately 3 dB.

Decimation - Allows you to toggle the decimation function between **Auto** and **Man**, and to set the decimation value. **Auto** is the preferred setting, and the only setting that guarantees alias-free FFT spectrum measurements. If you are familiar with the decimation feature, you can change the decimation value by setting to **Man**, but be aware that aliasing can result in higher values.

IF Flatness - Allows you to toggle between **On** and **Off**. When toggled to **On** (the default), the IF flatness feature causes background amplitude corrections to be performed on the FFT spectrum. The **Off** setting is used for adjustment and troubleshooting the transmitter tester.

Changing the View

View/Trace menu keys are used to activate a view of a measurement with preset X and Y scale parameters, called a “window”. Using the X and Y Scale keys you can then modify these parameter settings. You can also activate specific traces, using the **Trace Display** menu key.

Windows Available for Spectrum Measurements

The spectrum and the I/Q windows can be viewed at the same time, or individually. You can use the **Next Window** and **Zoom** keys to move between these different views.

Spectrum window Select this window if you want to view frequency and power. Changes to frequency span or power will sometimes affect data acquisition.

I/Q Waveform window. Select this window to view the I and Q signal characteristics of the current measurement in parameters of voltage and time.

NOTE

For the widest spans the I/Q window becomes just “ADC time domain samples”, because the I/Q down-conversion is no longer in effect.

Using the Markers

The **Marker** front-panel key accesses the menu to configure the markers. If you want to use the marker function in the I/Q window, press **View/Trace, I/Q Waveform, Marker, Trace, IQ Waveform**.

- **Select 1 2 3 4** - Allows you to activate up to four markers with the corresponding numbers, respectively. The selected number is underlined and its function is defined by pressing the **Function** key. The default is 1.
- **Normal** - Allows you to activate the selected marker to read the frequency and amplitude of the marker position on the spectrum trace, for example, which is controlled by the **RPG** knob.
- **Delta** - Allows you to read the differences in frequencies and amplitudes between the selected marker and the next.
- **Function Off** - Allows you to define the selected marker function to be **Band Power, Noise, or Off**. The default is **Off**. If set to **Band Power**, you need to select **Delta**.
- **Trace Spectrum** - Allows you to place the selected marker on the **Spectrum, Spectrum Avg, or I/Q Waveform** trace. The default is **Spectrum**.
- **Off** - Allows you to turn off the selected marker.
- **Shape Diamond** - Allows you to access the menu to define the selected marker shape to be a **Diamond, Line, Square, or Cross**. The default is a **Diamond**.
- **Marker All Off** - Allows you to turn off all of the markers.

The front panel **Search** key performs a peak search when pressed. A marker will automatically be activated at the highest peak.

Band Power

A band power measurement using the markers calculates the average power between two adjustable markers. To make a band power measurement:

Press the **Marker** key.

Press **Trace, Spectrum** to activate a marker on the instantaneous spectrum signal. Press the **Spectrum Avg** key to activate a marker on the average spectrum trace.

Press **Function, Band Power**.

Two marker lines are activated at the extreme left side of the horizontal scale. Press **Normal** and move marker 1 to the desired place by rotating the **RPG** knob.

Press **Delta** to bring marker 2 to the same place as marker 1.

Move marker 1 to the other desired position by rotating the **RPG** knob. Band power measures the average power between the two markers. When the band power markers are active, the results are shown in the results window as Mean Pwr (Between Mks). When the band power function is off the results window reads Mean Pwr (Entire Trace).

Troubleshooting Hints

Changes made by the user to advanced spectrum settings, particularly to ADC range settings, can inadvertently result in spectrum measurements that are invalid and cause error messages to appear. Care needs to be taken when using advanced features.

Making the Waveform (Time Domain) Measurement

Purpose

The waveform measurement is a generic measurement for viewing waveforms in the time domain. This measurement is how the instrument performs the zero span functionality found in traditional spectrum analyzers. Also available under basic mode waveform measurements is an I/Q window, which shows the I and Q signal in parameters of voltage and time. The advantage of having an I/Q view available while in the waveform measurement is that it allows you to view complex components of the same signal without changing settings or measurements.

The waveform measurement can be used to perform general purpose power measurements to a high degree of accuracy.

Measurement Method

The transmitter tester makes repeated power measurements at a set frequency, similar to the way a swept-tuned spectrum analyzer makes zero span measurements. The input analog signal is converted to a digital signal, which then is processed into a representation of a waveform measurement. The transmitter tester relies on a high rates of sampling to create an accurate representation of a time domain signal.

Making the Measurement

NOTE

The factory default parameters provide a good starting point. You will likely want to change some of the settings. Press **Meas Setup, More (1 of 2), Restore Meas Defaults** at any time to return all parameters for the current measurement to their default settings.

Press **Measure, Waveform (Time Domain)** to immediately make Waveform (Time Domain) the active measurement.

To change any of the measurement parameters from the factory default values, refer to the “Changing the Measurement Setup” section for this measurement.

Results

Figure 3-23 Waveform (Time Domain) Measurement - RF Envelope View

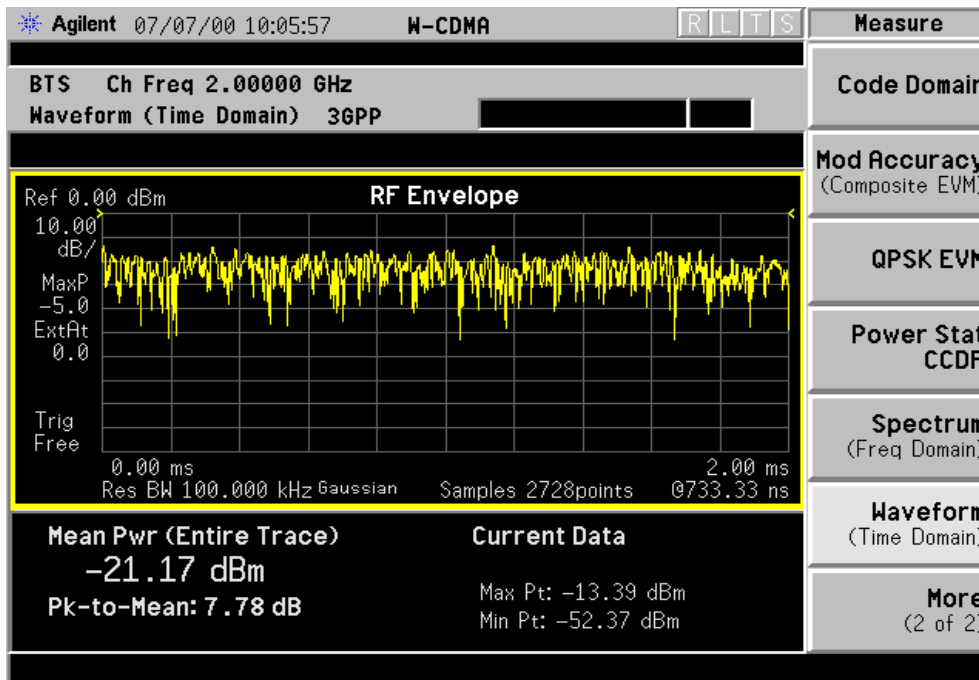
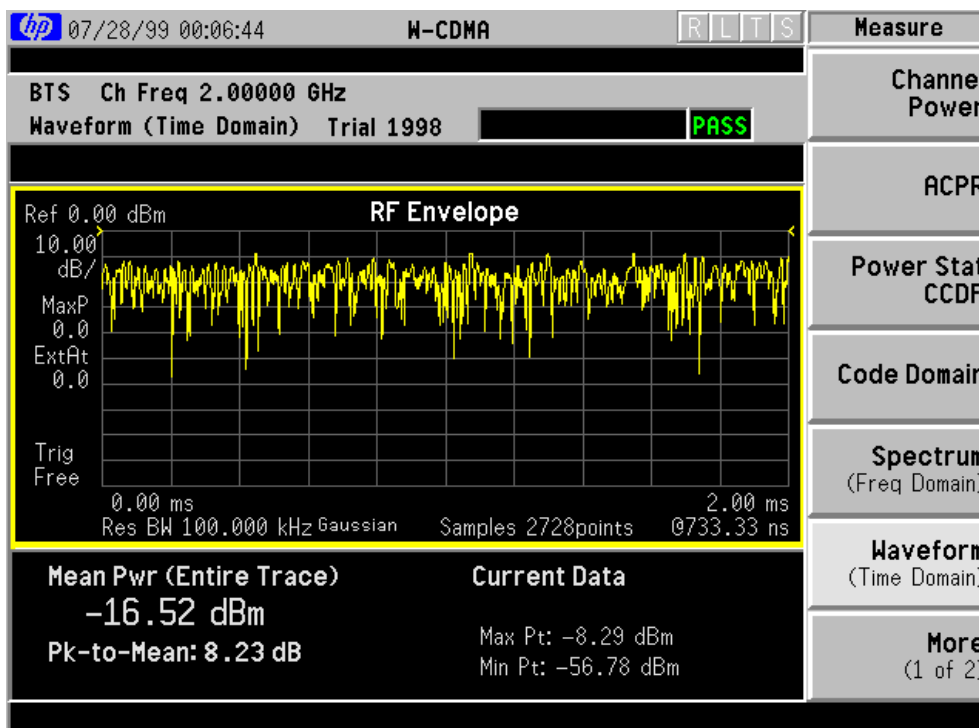

Figure 3-24 Waveform (Time Domain) Measurement - RF Envelope View



Changing the Measurement Setup

Table 2 Waveform (Time Domain) Measurement Defaults

Measurement Parameter	Factory Default Condition
View/Trace	RF Envelope
Sweep Time	2.000 ms
Res BW	100.000 kHz
Averaging:	
Avg Number	10 Off
Avg Mode	Exp
Avg Type	Pwr Avg (RMS)
Trigger Source	Free Run (Immediate)
RF Envelope Window:	
Amplitude Y Scale	
Scale/Div	10.00 dB
Reference	0.00 dBm (Top)
I/Q Waveform Window:	
Amplitude Y Scale	
Scale/Div	100.0 mv
Reference	0.00 V (Ctr)
Advanced	
Pre-ADC BPF	Off
RBW Filter	Gaussian
ADC Range	Auto
Data Packing	Auto
ADC Dither	Off
Decimation	Off

NOTE Parameters that are under the **Advanced** key seldom need to be changed. Any changes from the default values may result in invalid measurement data.

Make sure the **Waveform (Time Domain)** measurement is selected under the **Measure** menu. Press the **Meas Setup** key to access a menu which allows you to modify the averaging, and trigger source for this measurement (as described in the “Measurement Setup” section). In addition, the following parameters can be modified:

- **Sweep Time** - This key allows you to select the measurement acquisition time. It is used to specify the length of the time capture record. Values between 10 μ s and 50 s can be entered, depending upon the resolution bandwidth setting.
- **Res BW** - This key sets the measurement bandwidth. A larger bandwidth results in a larger number of acquisition points and reduces the maximum allowed for sweep time. You can enter values between 10 Hz. and 7.5 MHz.
- **Advanced menu key**. This key accesses the features listed below.

Pre-ADC BPF - This key allows you to toggle the pre-ADC bandpass filter to On or Off states. The pre-ADC bandpass filter is useful for rejecting nearby signals, so that sensitivity within the span range can be improved by increasing the ADC range gain

RBW Filter - This key toggles to select a flat top or a Gaussian resolution bandwidth filter. A Gaussian filter provides more even time domain response, particularly for bursts. A flat top filter provides a flatter bandwidth but is less accurate for pulse responses. A flat top filter also requires less memory and allows longer data acquisition times. For most waveform applications, the Gaussian filter is recommended, and it is the default filter for waveform measurements.

ADC Range -.Allows you to access the following selection menu to define one of the following ADC ranging functions:

- **Auto** - This key causes the instrument to automatically adjust the signal range for optimal measurement results.
- **AutoPeak** - This key causes the instrument to continuously seek the highest peak signal.
- **AutoPeakLock** - This key causes the instrument to adjust the range for the highest peak signal it identifies, and retains the range settings determined by that peak signal, even when the peak signal is no longer present.
- **Manual** - Allows you to access the selection menu: **-6 dB, 0 dB, +6 dB, +12 dB, +18 dB, +24 dB**, to set the ADC range level. Also note that manual ranging is best for CW signals.

Data Packing - Allows you to access the following selection menu to define one of the following data packing methods:

- **Auto** - Data is automatically packed. This is the default setting and most recommended.

- **Short (16 bit)** - Data is packed by every 16 bits.
- **Medium (24 bit)** - Data is packed by every 24 bits.
- **Long (32 bit)** - Data is packed by every 32 bits.

ADC Dither - Allows you to toggle the ADC dither function between **On** and **Off**. Activation of the ADC dither results in better amplitude linearity and resolution in low level signals. However, it also results in reduced dynamic range. ADC dither is set to **Off** by default.

Decimation - Allows you to toggle the decimation function between **On** and **Off** and to set the decimation value. Decimation allows longer acquisition times for a given bandwidth by eliminating data points. Long time captures can be limited by the transmitter tester data acquisition memory. Decimation numbers 1 to 4 describe the factor by which the number of points are reduced. A decimation figure of 1, which results in no data point reduction, is the default.

Changing the View

The **View/Trace** menu keys are used to activate a view of a measurement with preset X and Y scale parameters; this view is called a “window.” Using the X and Y scale keys, you can then modify these parameters. You can also activate traces, using the **Traces Display** menu key.

Windows Available for Waveform Measurements

RF Envelope window. Select this window if you want to view power (in dBm) vs. time. Remember that data acquisition will be affected when you change the sweep time.

I/Q Waveform window. Select this window to view the I and Q signal characteristics of the current measurement in parameters of voltage and time.

Using the Markers

The **Marker** front-panel key accesses the menu to configure the markers. If you want to use the marker function in the I/Q window, press **View/Trace, I/Q Waveform, Marker, Trace, IQ Waveform**.

- **Select 1 2 3 4** - Allows you to activate up to four markers with the corresponding numbers, respectively. The selected number is underlined and its function is defined by pressing the **Function** key. The default is 1.
- **Normal** - Allows you to activate the selected marker to read the frequency and amplitude of the marker position on the spectrum trace, for example, which is controlled by the **RPG** knob.
- **Delta** - Allows you to read the differences in frequencies and amplitudes between the selected marker and the next.
- **Function Off** - Allows you to define the selected marker function to be **Band Power, Noise, or Off**. The default is **Off**. If set to **Band Power**, you need to select **Delta**.
- **Trace Spectrum** - Allows you to place the selected marker on the **Spectrum, Spectrum Avg, or I/Q Waveform** trace. The default is **Spectrum**.
- **Off** - Allows you to turn off the selected marker.
- **Shape Diamond** - Allows you to access the menu to define the selected marker shape to be a **Diamond, Line, Square, or Cross**. The default is a **Diamond**.
- **Marker All Off** - Allows you to turn off all of the markers.

The front panel **Search** key performs a peak search when pressed. A marker will automatically be activated at the highest peak.

NOTE

In the Waveform measurement, the Mean Pwr (Entire Trace) value plus the Pk-to-Mean value will sum to equal the current Max Pt. value as shown in the data window below the RF Envelope display. If you do a marker peak search (**Search**) with averaging turned off, the marker will find the same maximum point. However, if you turn averaging on, the Pk-to-Mean value will use the highest peak found for any acquisition during averaging, while the marker peak will look for the peak of the display, which is the result of n-averages. This will usually result in differing values for the maximum point.

Band Power

A band power measurement using the markers calculates the average power between two adjustable markers. To make a band power measurement:

Press the **Marker** key.

Press **Function, Band Power**.

Two marker lines are activated at the extreme left side of the horizontal scale. Press **Normal** and move marker 1 to the desired place by rotating the **RPG** knob.

Press **Delta** to bring marker 2 to the same place as marker 1.

Move marker 1 to the other desired position by rotating the **RPG** knob. Band power measures the average power between the two markers. When the band power markers are active, the results are shown in the results window as Mean Pwr (Between Mks). When the band power function is off the results window reads Mean Pwr (Entire Trace).

Troubleshooting Hints

Changes made by the user to advanced waveform settings can inadvertently result in measurements that are invalid and cause error messages to appear. Care needs to be taken when using advanced features.

4

Setting Up the W-CDMA (Trial & Arib) Mode

W-CDMA (Trial & Arib) Mode

You may want to install a new personality, reinstall a personality that you have previously uninstalled, or uninstall a personality. Instructions for installing and uninstalling personality options are under [“Installing Optional Measurement Personalities” on page 188](#).

At initial power up, the transmitter tester will come up in the Basic mode, with the Spectrum (frequency domain) measurement selected and the **Measure** menu displayed.

To access the W-CDMA (Trial & Arib) measurement personality, press the **Mode** key and select the **W-CDMA (Trial & Arib)** key.

If you want to set the W-CDMA (Trial & Arib) mode to a known, factory default state, press **Preset**. This will preset the mode setup and all of the measurements to the factory default parameters.

NOTE

Pressing the **Preset** key does not switch instrument modes.

How to Make a Measurement

Follow the three-step procedure shown in the table below:

Step	Primary Key	Setup Key	Related Key
1. Select & setup a mode.	Mode	Mode Setup, Input, Frequency Channel	System
2. Select & setup a measurement.	Measure	Meas Setup	Meas Control, Restart
3. Select & setup a view.	View/Trace	Span X Scale, Amplitude Y Scale, Display, Next Window, Zoom	File, Save, Print, Print Setup, Marker, Search

Step 1. Select & setup a mode as follows, for example:

- Press the **Mode** key and select **W-CDMA (Trial & Arib)**.
- Press the **Frequency Channel** key and enter the channel frequency to be measured.
- Press the **Mode Setup** key and change the **Radio, Input, and Trigger** conditions from those default settings.

Refer to [“Changing the Mode Setup” on page 166](#) and [“Changing the Frequency Channel” on page 170](#) for further explanation.

Refer to “[Mode Setup / Frequency Channel Key Flow](#)” on page 172 for the key flow diagrams.

Step 2. Select & setup a measurement as follows, for example:

- Press the **Measure** key to select either **Channel Power**, **ACPR**, **Power Stat CCDF**, **Code Domain**, **Spectrum (Freq Domain)**, **Waveform (Time Domain)**, **QPSK EVM**, or **Mod Accuracy (Perch Only)** to make its measurement.
- Press the **Meas Setup** key to change any of the measurement parameters from the default settings. These parameters such as **Span**, **Resolution Bandwidth**, **Trigger Source**, **Average**, **Limit Test** and **Limits**, are decided according to the measurement selected.

Refer to “[Channel Power Measurement Key Flow](#)” on page 173 and to “[Waveform \(Time Domain\) Measurement Key Flow \(1 of 2\)](#)” on page 186 for the key flow diagrams.

Step 3. Select & setup a view as follows, for example:

- Press the **View/Trace** key to select the desired view for the current measurement.
- Press the **Next Window** key to select a window, then press the **Zoom** key to expand the window to the full display area.
- Press the **Span X Scale**, **Amplitude Y Scale**, **Display**, and/or **Marker** keys for your desired display. These keys are not always available for each view.

Refer to “[Channel Power Measurement Key Flow](#)” on page 173 and to “[Waveform \(Time Domain\) Measurement Key Flow \(1 of 2\)](#)” on page 186 for the key flow diagrams.

Entering a Numeric Value

Three methods are available to enter a numeric value for an active softkey, however, its resolution can be different depending on the method selected and the range, if any. The highest resolutions are described throughout this guide.

- **Numeric keys** - Allows you to enter a value with the highest resolution by pressing the numeric keys. The entry is terminated by pressing the **Enter** key or one of the unit softkeys shown.
- **RPG knob** - Allows you to continuously change the value shown on the softkey with the medium or highest resolution defined to the parameter by rotating this knob.
- **Step (Up/Down arrow) keys** - Allows you to change the value shown on the softkey with the fixed-step resolution defined to the parameter activated. While the ↑ (up arrow) key is pressed down, for example, the value increases in multiple steps defined to the parameter.

Changing the Mode Setup

Numerous settings can be changed at the mode level by pressing the **Mode Setup** key. This will access the menu with the selections listed below. The factory default settings are shown in tables. These settings affect only the measurements in the W-CDMA mode.

Configuring the Radio Setting

The **Radio** key accesses the menu as follows:

- **Device** - Allows you to toggle the test device between **BTS** (Base Transmission Station) and **MS** (Mobile Station).
- **MS-BTS Offset** - Allows you to specify the frequency space between MS and BTS. The range is -500.000 MHz to 500.000 MHz with 1 kHz resolution.
- **Standard** - Allows you to access the menu to select one of the standards as follows:
 - ARIB 1.0-1.2** - Allows you to make measurements compliant to the ARIB 1.0-1.2 document submitted to 3GPP.
 - 3GPP** - Allows you to make measurements compliant to the evolving third generation partnership project document.
 - Trial 1998** - Allows you to make measurements compliant to the W-CDMA trial system that originated in Japan.

Radio Default Settings	
Device	BTS
MS-BTS Offset	190.000 MHz
Standard	Trial 1998

Configuring the Input Setting

The **Input** key accesses the menu as follows: (You can also access this menu from the **Input** front-panel key.)

- **RF Input Range** - Allows you to toggle the RF input range control between **Auto** and **Man** (manual). If **Auto** is chosen, the instrument automatically sets the attenuator based on the carrier power level, where it is tuned. Once you change the **Max Total Pwr** or **Input Atten** value with the RPG knob, for example, the **RF Input Range** key is automatically set to **Man**. If there are multiple carriers present, the total power might overdrive the front end. In this case you need to set the **RF Input Range** to **Man** and enter the expected maximum total power by activating the **Max Total Pwr** key. **Man** is also useful to hold the input attenuation constant for the best relative power accuracy. For single carriers it is generally recommended to set this to **Auto**.

- **Max Total Pwr** - Allows you to set the maximum total power level from the UUT (Unit Under Test). The range is -200.00 to 100.00 dBm with 0.01 dB resolution. This is the expected maximum value of the mean carrier power referenced to the output of the UUT; it may include multiple carriers. The **Max Total Pwr** setting is coupled together with the **Input Atten** and **Ext Atten** settings. Once you change the **Max Total Pwr** value with the RPG knob, for example, the **RF Input Range** key is automatically set to **Man**.
- **Input Atten** - Allows you to control the internal input attenuator setting. The range is 0 to 40 dB with 1 dB resolution. The **Input Atten** key reads out the actual hardware value that is used for the current measurement. If more than one input attenuator value is used in a single measurement, the value used at the carrier frequency will be displayed. The **Input Atten** setting is coupled to the **Max Total Pwr** setting. Once you change the **Input Atten** setting with the RPG knob, for example, the **RF Input Range** key is automatically set to **Man**.
- **Ext Atten** - Allows you to access the following menu to enter the external attenuation values. Either of the **Ext Atten** settings is coupled together with the **RF Input Range** setting, however, pressing **Ext Atten** does not switch the **RF Input Range** key to **Man**. This will allow the instrument to display the measurement results referenced to the output of the UUT.

MS - Allows you to set an external attenuation value for MS tests. The range is -50.00 to $+50.00$ dB with 0.01 dB resolution.

BTS - Allows you to set an external attenuation value for BTS tests. The range is -50.00 to $+50.00$ dB with 0.01 dB resolution.

Input Default Settings	
RF Input Range	Auto ^a
Max Total Pwr	-15.00 dBm ^b
Input Atten	0.00 dB ^b
Ext Atten:	
MS	0.00 dB
BTS	0.00 dB

- Auto is not used for Spectrum measurements.
- This may differ if the maximum input power is more than -15.00 dBm, or depending on the previous measurements.

NOTE

The **Max Total Pwr** and the **Input Atten** settings are coupled together. When you switch to a different measurement, the **Max Total Pwr** setting is kept constant, but the **Input Atten** setting may change if the two measurements have different mixer margins. Thus, you can directly set the transmitter tester input attenuator, or you can set it indirectly by specifying the expected maximum power at the UUT (Max Total Pwr setting).

Configuring the Trigger Condition

The **Trigger** key allows you: (1) to access the trigger selection menu to specify each triggering condition, (2) to modify the default trigger holdoff time using the **Trig Holdoff** key, (3) to modify the auto trigger time and to activate or deactivate the auto trigger feature using the **Auto Trig** key, and (4) to modify the period of the frame timer using the **Frame Timer** key.

NOTE

The actual trigger source is selected separately for each measurement under the **Meas Setup** key.

- **RF Burst, Video (IF Envlp), Ext Front and Ext Rear** - Pressing one of these trigger keys will access each triggering condition setup menu. This menu is used to specify the **Delay**, **Level** and **Slope** settings for each trigger source as follows:

Delay - Allows you to enter a numerical value to modify the trigger delay time. The range is -100.0 to $+500.0$ ms with $1 \mu\text{s}$ resolution. For trigger delay use a positive value, and for pre-trigger use a negative value.

Level - Allows you to enter a numerical value to adjust the trigger level depending on the trigger source selected.

For **RF Burst** selection, the key label reads as **Peak Level**. The RF level range is -25.00 to 0.00 dB with 0.01 dB resolution, relative to the peak RF signal level. The realistic range can be down to -20 dB.

For **Video (IF Envlp)** selection, the video level range is -200.00 to $+50.00$ dBm with 0.01 dB resolution at the RF input. The realistic range can be down to around -50 dBm depending on the noise floor level of the input signal.

For **Ext Front** or **Ext Rear** selection, the level range is -5.00 to $+5.00$ V with 1 or 10 mV resolution.

Slope - Allows you to toggle the trigger slope between **Pos** at the positive-going edge and **Neg** at the negative-going edge of the burst signal.

There are other keys under the **Trigger** key as follows:

- **Trig Holdoff** - Allows you to set the period of time before the next trigger can occur. The range is 0.000 μ s to 500.0 ms with 1 μ s resolution.
- **Auto Trig** - Allows you to specify a time for a trigger timeout and toggle the auto trigger function between **On** and **Off**. The range is 1.000 ms to 1.000 ks with 1 μ s resolution. If no trigger occurs by the specified time, a trigger is automatically generated.
- **Frame Timer** - Allows you to access the menu to manually control the frame timer:
 - Period** - Allows you to set the period of the frame clock. The range is 0.000 ns to 559.0000 ms with 1 ps resolution.
 - Offset** - Allows you to set the offset of the frame clock. The range is 0.000 to 10.00 s with 100 ns resolution over 1.000 μ s range.
 - Reset Offset Display** - Allows you to display without any offset of the frame clock.
 - Sync Source** - Allows you to access the menu to select one of the sources to be synchronized with.
 - Off** - Allows you to turn the synchronizing source off for asynchronous tests.
 - RF Burst (Wideband)** - Allows you to select the RF burst signal as the synchronizing source.
 - Ext Front** - Allows you to select the external input signal from the front-panel input port as the synchronizing source.
 - Ext Rear** - Allows you to select the external input signal from the rear panel input port as the synchronizing source.

Trigger Default Settings	
RF Burst:	
Delay	0.000 μ s
Peak Level	-6.00 dB
Slope	Pos
Video (IF Envlp):	
Delay	0.000 μ s
Level	-6.00 dBm
Slope	Pos
Ext Front:	
Delay	0.000 μ s
Level	2.00 V
Slope	Pos
Ext Rear:	
Delay	0.000 μ s
Level	2.00 V
Slope	Pos
Trig Holdoff	0.000 ms
Auto Trig	100.0 ms, On
Frame Timer:	
Period	10.00000 ms
Offset	0.000 ms
Sync Source	Off

Changing the Frequency Channel

After selecting the desired mode setup, you will need to select the desired center frequency and the center frequency step. The selections made here will apply to all measurements in the mode. Press the **Frequency Channel** key to access the following menu:

- **Center Freq** - Allows you to enter a frequency that corresponds to the desired RF channel to be measured. This is the current instrument center frequency. The range is 1.000 kHz to 4.32140 GHz with 1 Hz resolution.
- **CF Step** - Allows you to enter a center frequency step to shift the measurement segment, and to toggle the step function between **Auto** and **Man**. If set to **Auto**, the **CF Step** value automatically changes according to the selection of the standard. The range is 1.000 kHz to 1.00000 GHz with 1 Hz resolution.

Frequency Channel Default Settings	
Frequency Channel:	
Center Freq	1.00000 GHz
CF Step	5.00000 MHz, Auto

W-CDMA Measurement Key Flow

The key flow diagrams, shown in a hierarchical manner on the following pages, will help grasp the overall functional relationships for the front-panel keys and the softkeys displayed at the extreme right side of the screen. The diagrams are:

- “Mode Setup / Frequency Channel Key Flow” on page 172,
- “Channel Power Measurement Key Flow” on page 173,
- “ACPR Measurement Key Flow” on page 174,
- “Power Stat CCDF Measurement Key Flow” on page 175
- “Code Domain Measurement Key Flow (1 of 3)” on page 176
- “QPSK EVM Measurement Key Flow (1 of 2)” on page 179
- “Modulation Accuracy Measurement Key Flow (1 of 2)” on page 181
- “Spectrum (Freq Domain) Measurement Key Flow (1 of 3)” on page 183
- “Waveform (Time Domain) Measurement Key Flow (1 of 2)” on page 186

Use these flow diagrams as follows:

- There are some basic conventions:

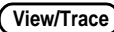
 View/Trace

An oval represents one of the front-panel keys.

 QPSK EVM

This box represents one of the softkeys displayed.

 <for EVM>

This represents an explanatory description on its specific key.

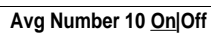
 Avg Number 10 On|Off

This box shows how the softkey default condition is displayed. Default parameters or values are underlined wherever possible.

- Start from the extreme upper left corner of each measurement diagram to the right direction, and go from the top to the bottom.
- When defining a key from auto with underline to manual, for example, just press that key one time.
- When entering a numeric value of **Frequency**, for example, use the numeric keypad by terminating with the appropriate unit selection from the softkeys displayed.
- When entering a numeric value of **Avg Number**, for example, use the numeric keypad by terminating with the **Enter** front-panel key.
- Instead of using the numeric keypad to enter a value, it may be easier to use the RPG knob or **Up/Down** keys depending on the input field of a parameter.

Figure 4-1 Mode Setup / Frequency Channel Key Flow

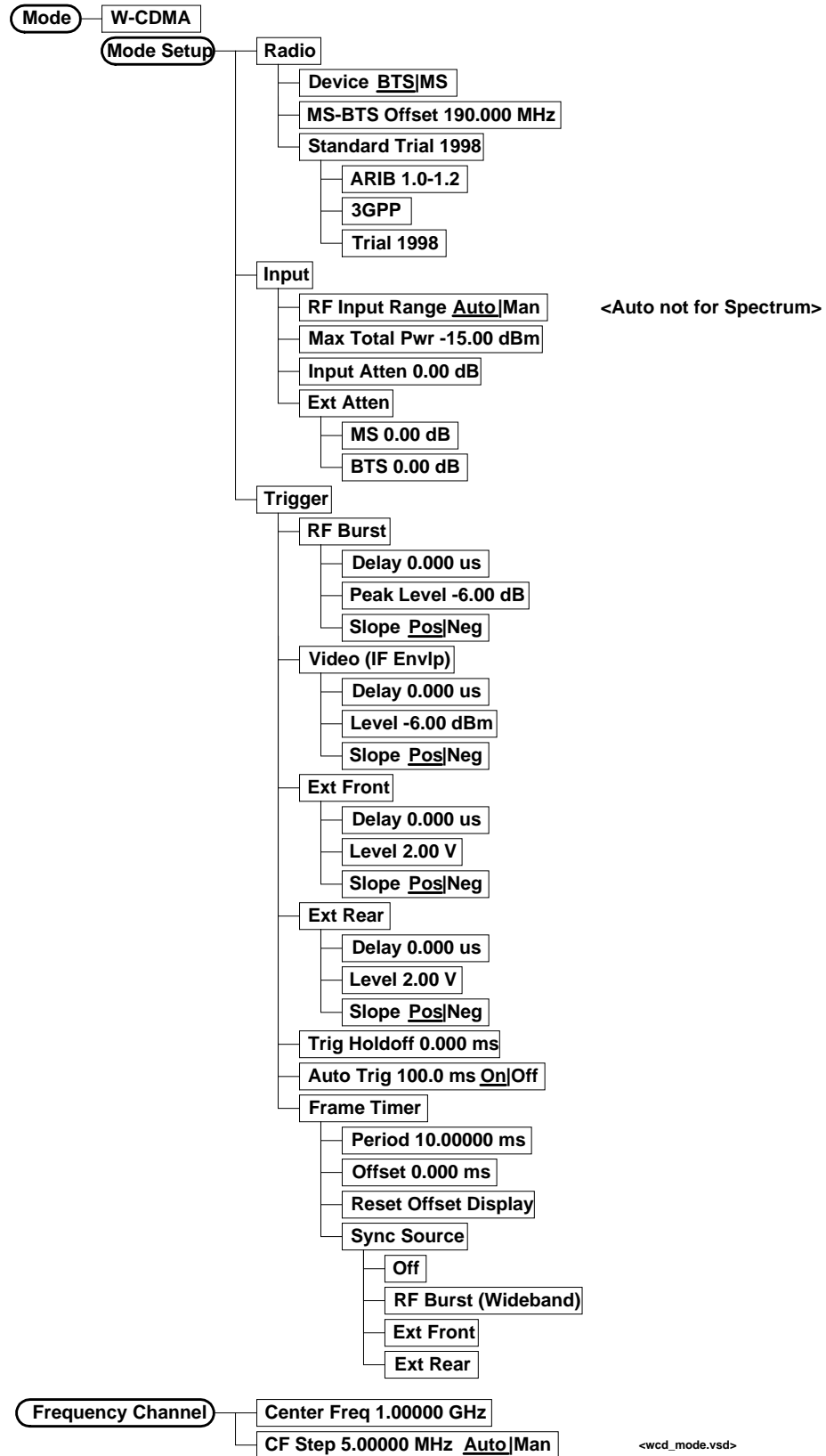

Figure 4-2 Channel Power Measurement Key Flow

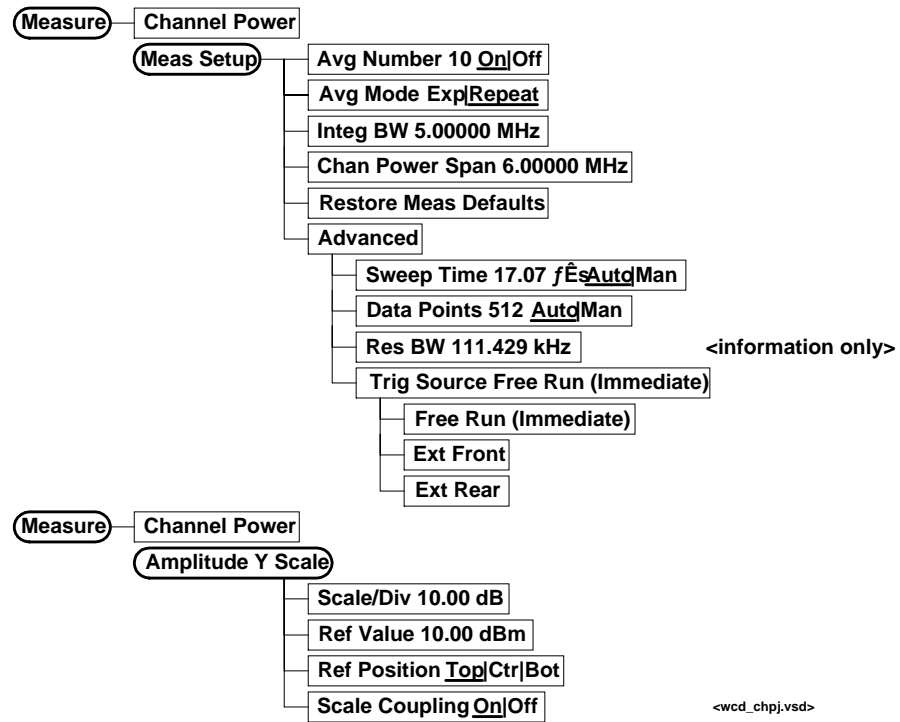

Figure 4-3 ACPR Measurement Key Flow

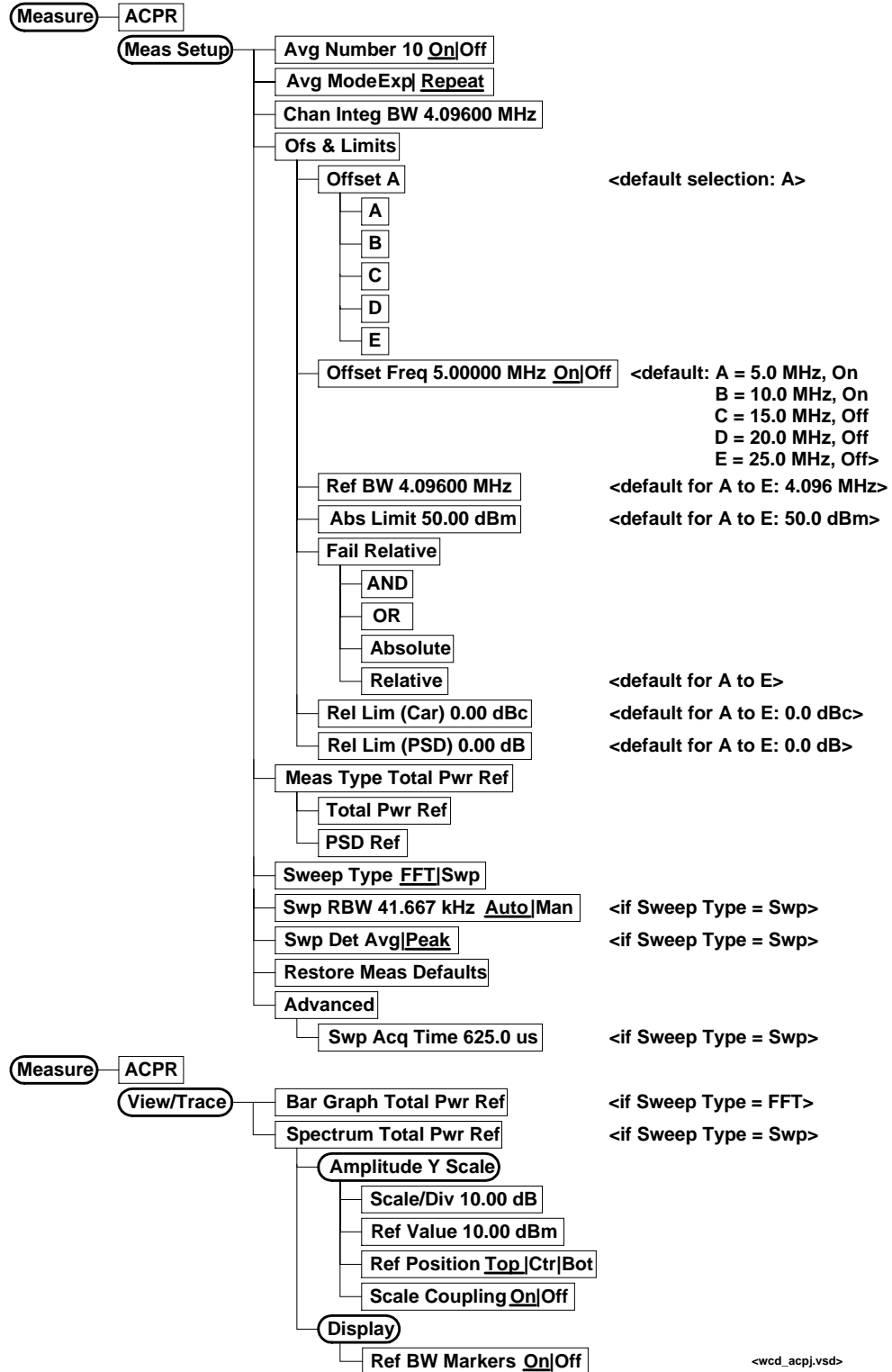
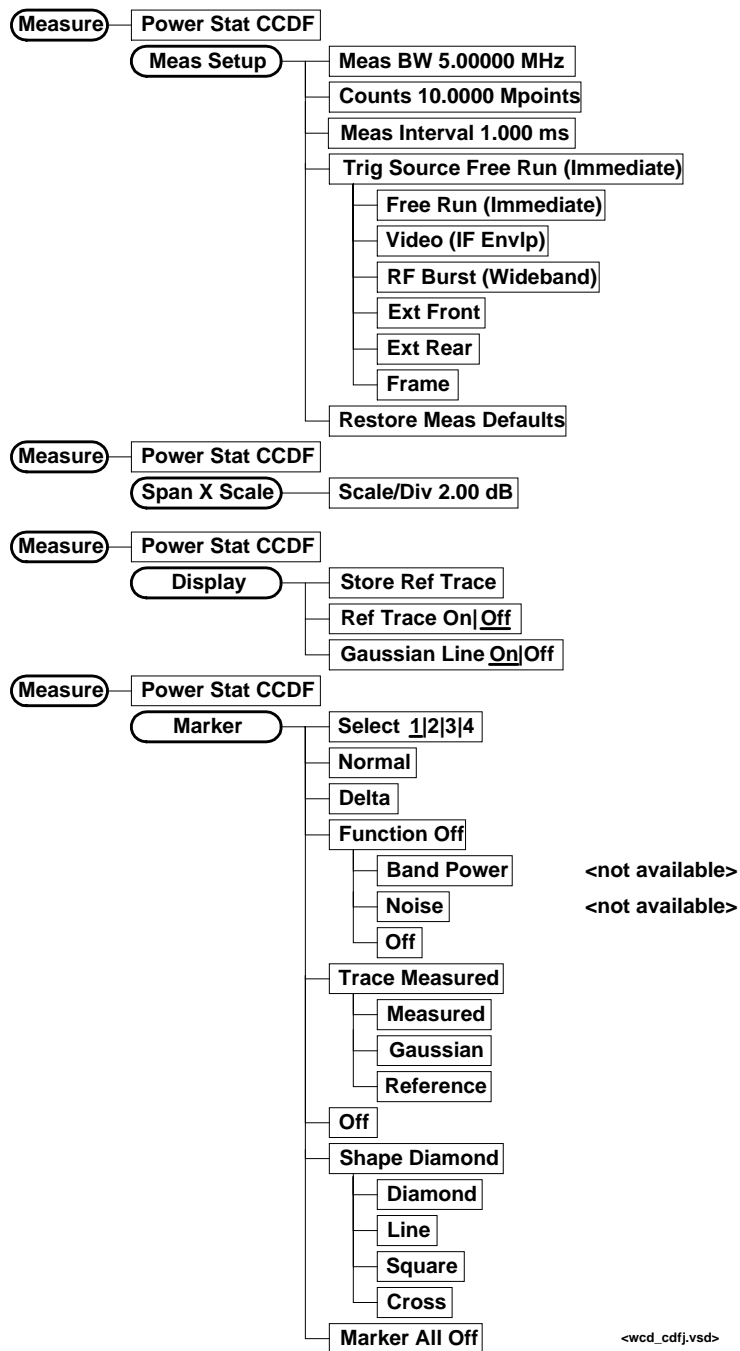

Figure 4-4 Power Stat CCDF Measurement Key Flow



<wcd_cdfj.vsd>

Figure 4-5 Code Domain Measurement Key Flow (1 of 3)

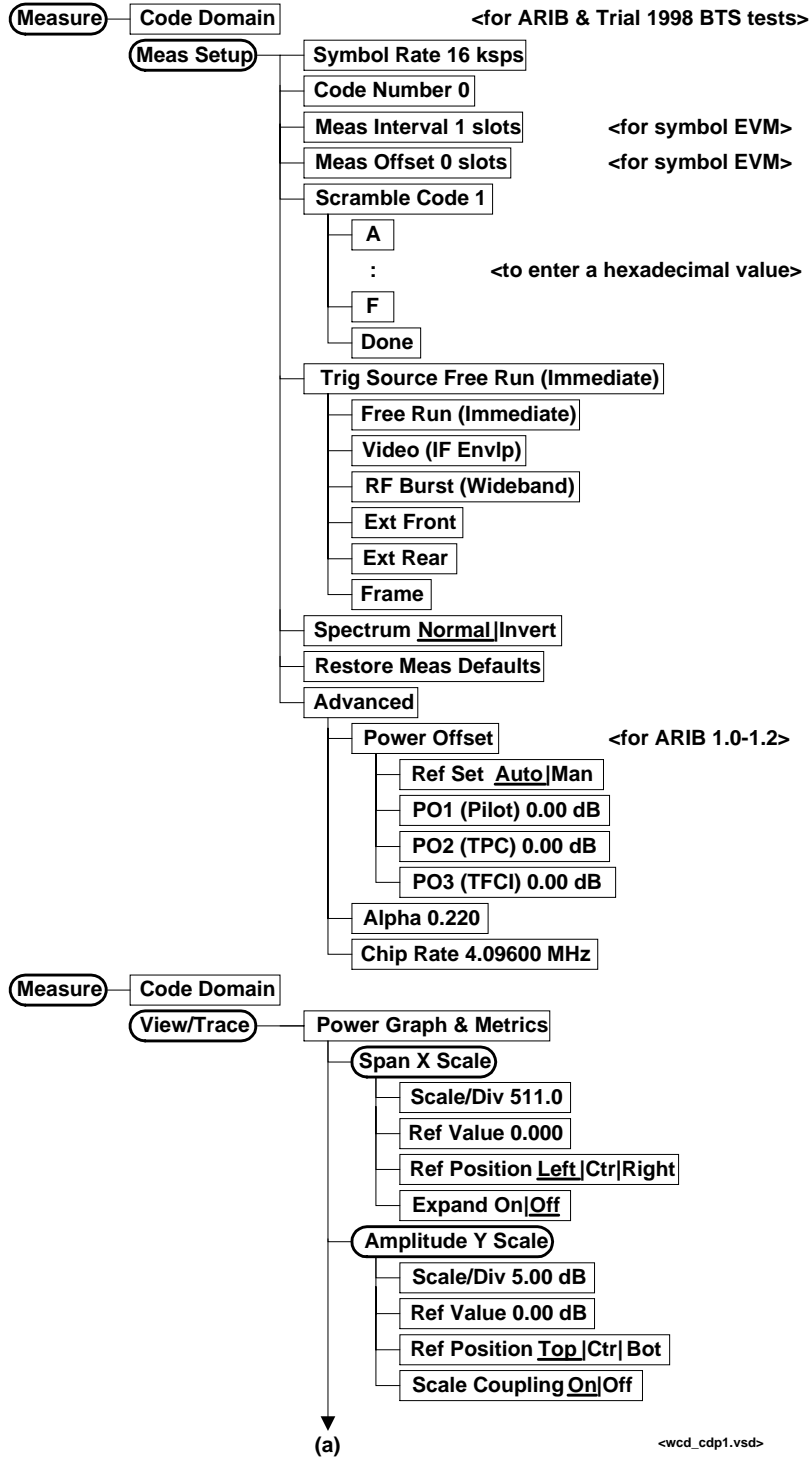

Figure 4-6 Code Domain Measurement Key Flow (2 of 3)

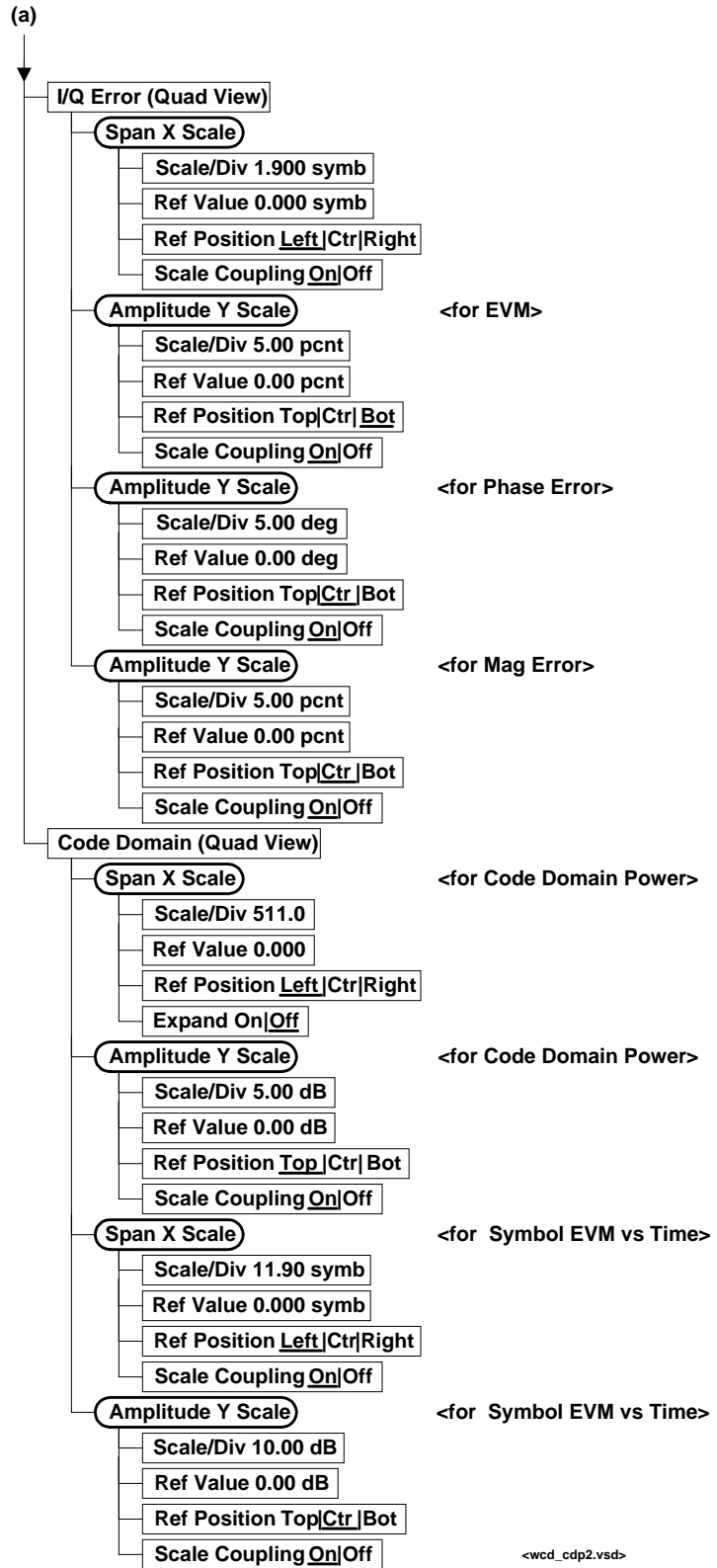

Figure 4-7

Code Domain Measurement Key Flow (3 of 3)

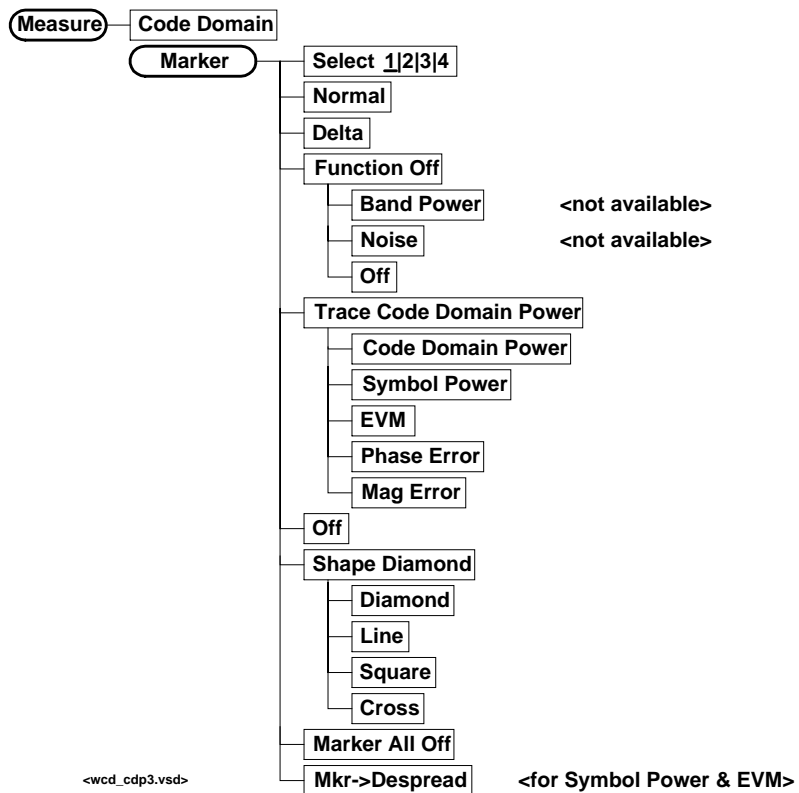

Figure 4-8 QPSK EVM Measurement Key Flow (1 of 2)

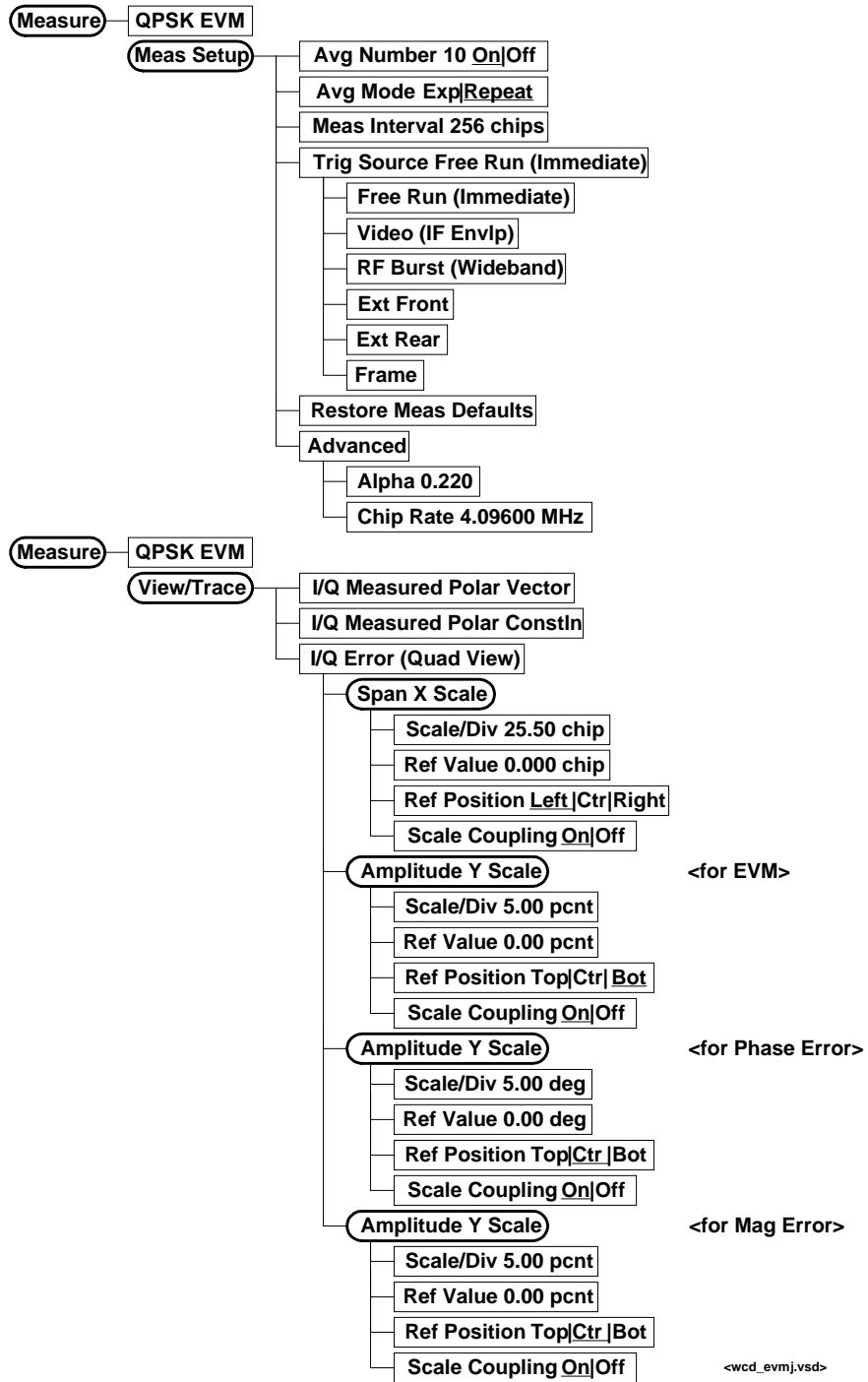

Figure 4-9 QPSK EVM Measurement Key Flow (2 of 2)

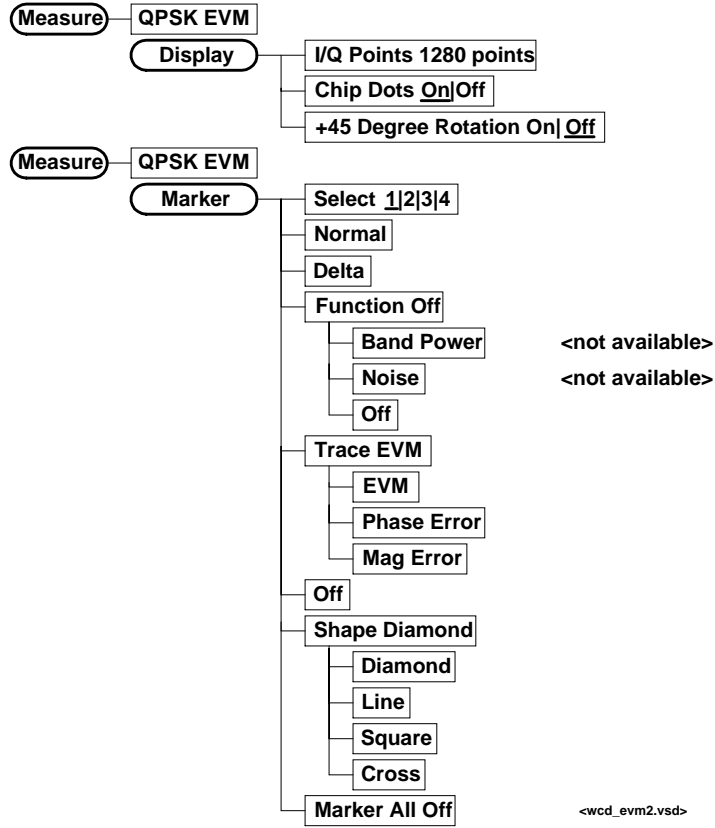
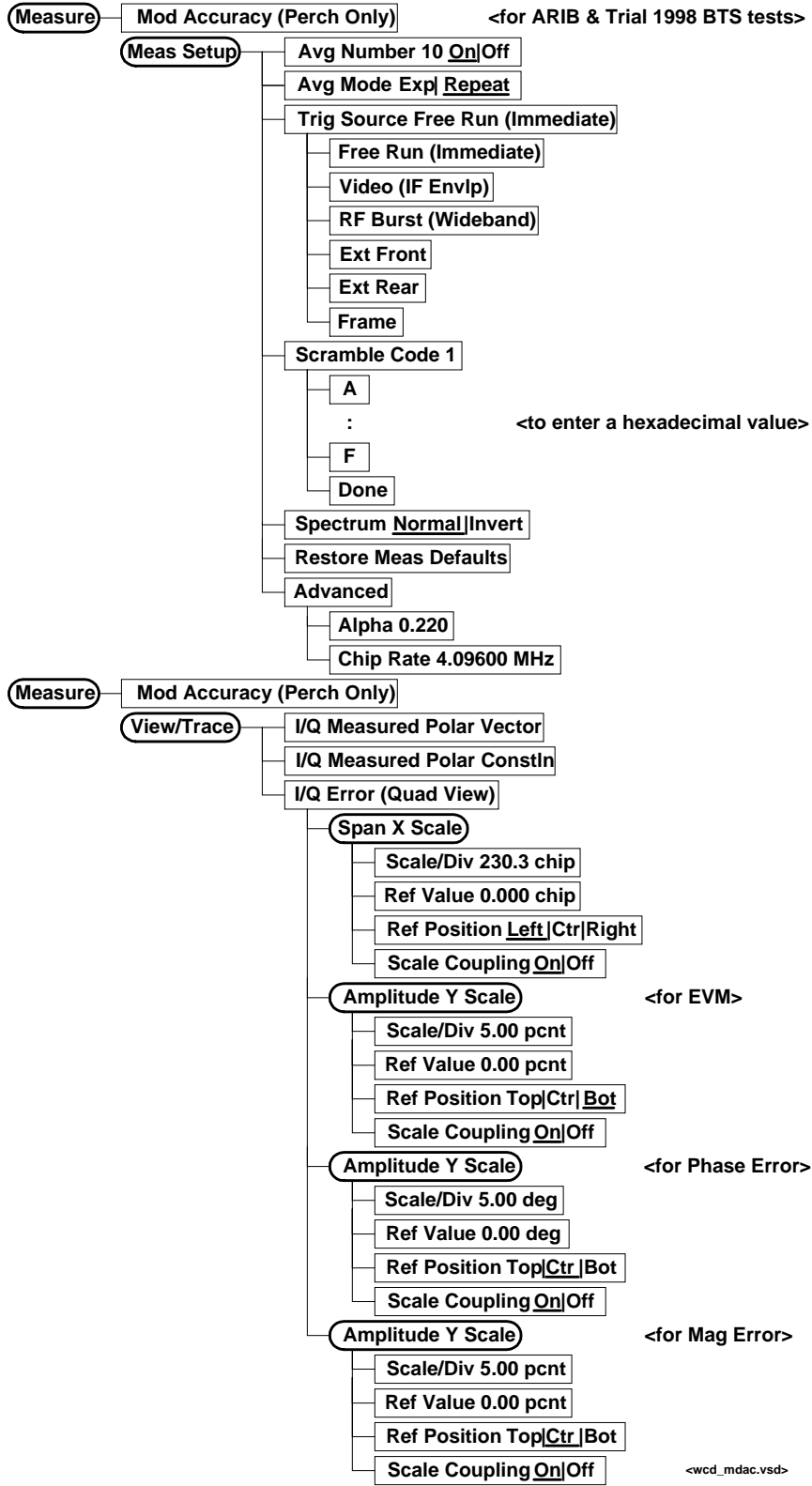

Figure 4-10 Modulation Accuracy Measurement Key Flow (1 of 2)



<wcd_mdac.vsd>

Figure 4-11 Modulation Accuracy Measurement Key Flow (2 of 2)

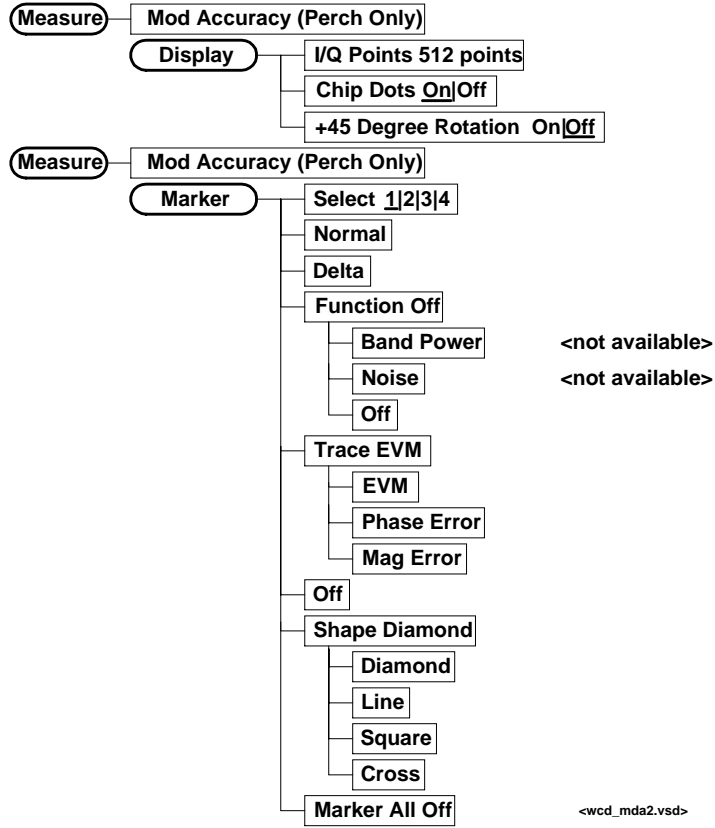

Figure 4-12 Spectrum (Freq Domain) Measurement Key Flow (1 of 3)

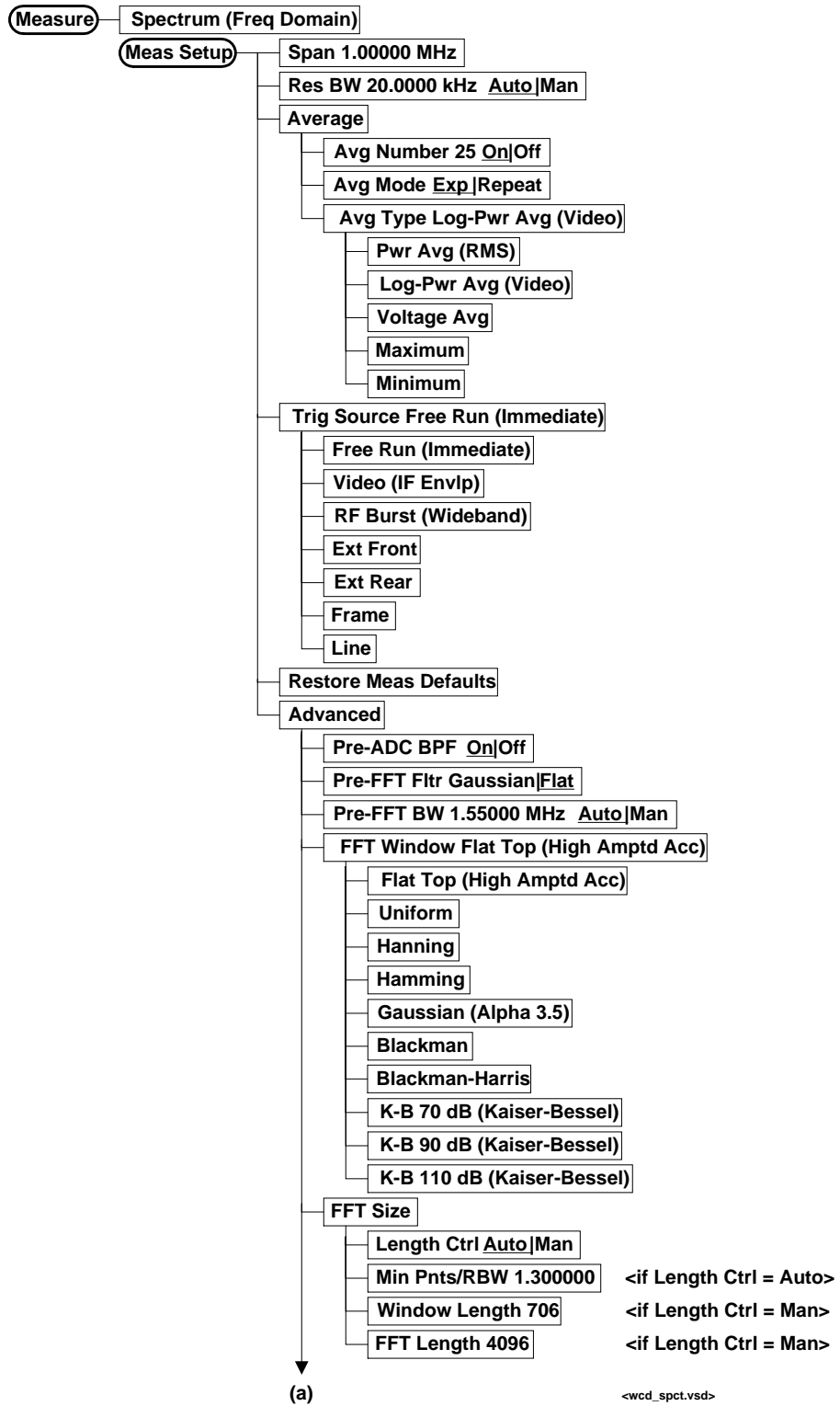
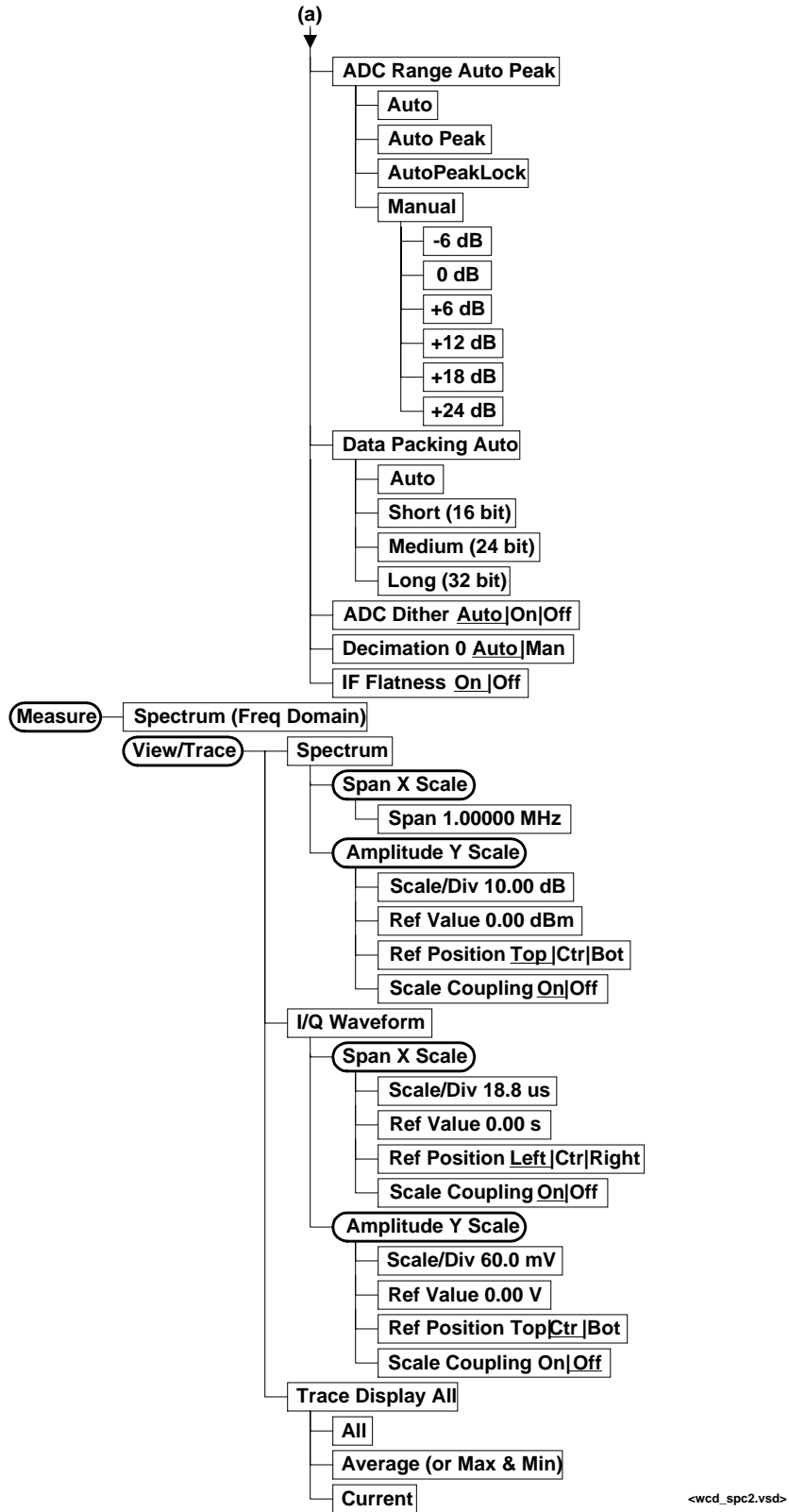

Figure 4-13 Spectrum (Freq Domain) Measurement Key Flow (2 of 3)



<wcd_spc2.vsd>

Figure 4-14 Spectrum (Freq Domain) Measurement Key Flow (3 of 3)

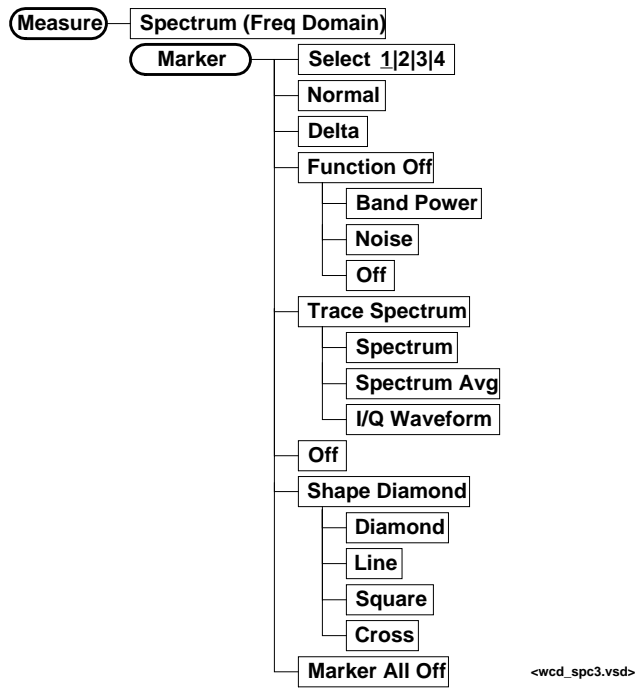

Figure 4-15 Waveform (Time Domain) Measurement Key Flow (1 of 2)

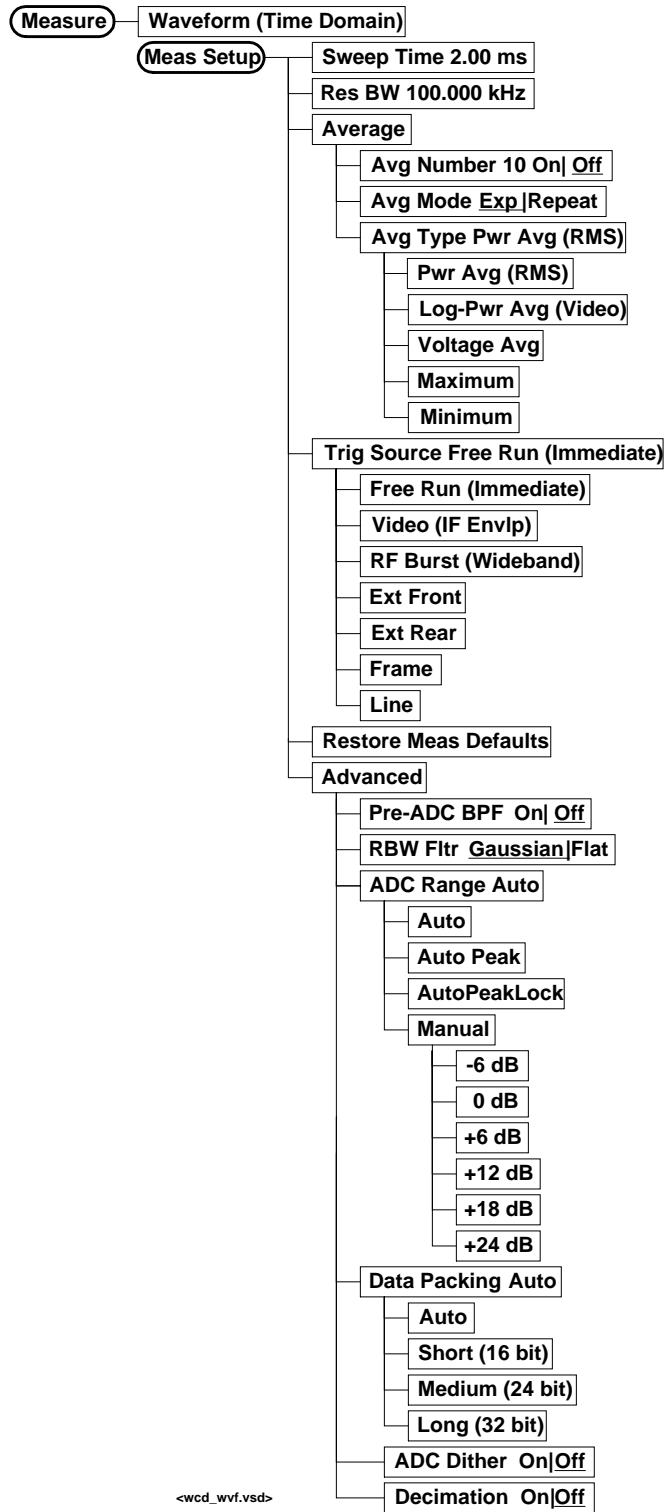
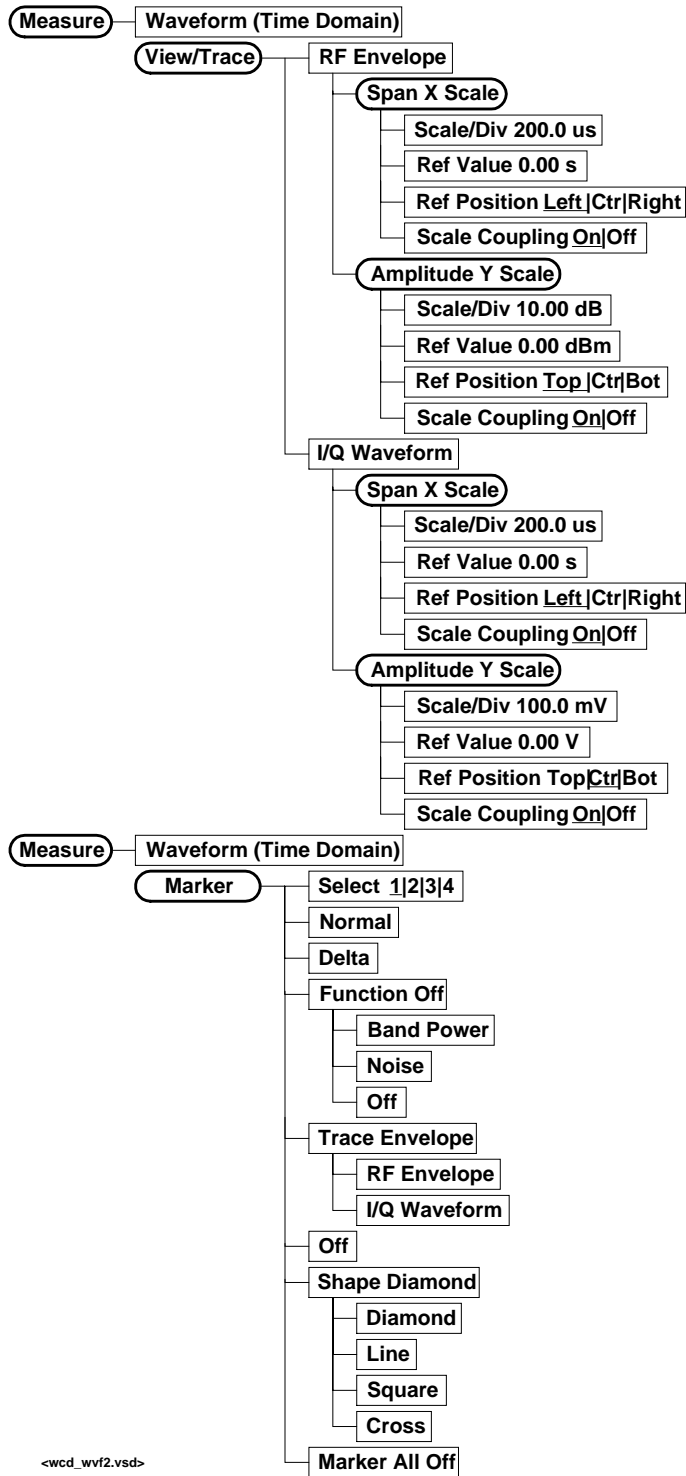

Figure 4-16 Waveform (Time Domain) Measurement Key Flow (2 of 2)



Installing Optional Measurement Personalities

When you install a measurement personality, you follow a two step process.

1. Install the measurement personality firmware into the instrument. (See the supplied installation instructions.)
2. Enter a license key number to enable the measurement personality. (Refer to the “License Key Numbers” section below.)

Adding additional measurement personalities requires purchasing a retrofit kit for the desired option. The retrofit kit contains the measurement personality firmware. A license key certificate is also included in the kit. It documents the license key number that is for your specific option and instrument serial number. Installation instructions are included with the retrofit kit.

The installation instructions require you to know three pieces of information about your instrument: the amount of memory installed, the Host ID, and the instrument serial number.

Required information:	Key Path:
Instrument Memory: _____	System, File System (the amount of memory in your instrument will be the sum of the <i>Used</i> memory and the <i>Free</i> memory)
Host ID: _____	System, Show System, Host ID
Instrument Serial Number: _____	System, Show System, Serial Number

The **Exit Main Firmware** key is used during the firmware installation process. This key is only for use when you want to update firmware using a LAN connection. The **Exit Main Firmware** key halts the operation of the instrument firmware so you can install an updated version of firmware using a LAN connection. Instructions for loading future firmware updates are available at the following URL:
www.agilent.com/find/vsa/

Available Personality Options

The option designation consists of three characters, as shown in the Option column of the table below.

Available Personality Options ^a	Option
GSM measurement personality	BAH
EDGE (with GSM) measurement personality ^b	202
cdmaOne measurement personality	BAC
NADC, PDC measurement personalities	BAE
iDEN measurement personality	HN1
W-CDMA measurement personality	BAF
cdma2000 measurement personality	B78

- a. Available as of the print date of this guide.
- b. For instruments that already have Option BAH licensed, order E4406AU Option 252 to add EDGE (with GSM).

License Key Numbers

Measurement personalities purchased with your instrument have been installed and enabled at the factory. You will receive a unique License Key number with every measurement personality purchased. The license key number is a hexadecimal number that is for your specific measurement personality and instrument serial number. It enables you to install, or reactivate that particular personality.

Follow these steps to display the unique license key number for the measurement personality that is installed in your instrument:

1. Press **System, Install, Choose Option**. The **Choose Option** key accesses the alpha editor. Use the alpha editor to enter letters (upper-case) and the front-panel numeric keys to enter digits for a personality option that is already installed in the instrument.
2. Press the **Done** key on the alpha editor menu. The unique license key number for your instrument will now appear on the **License Key** softkey.

You will want to keep a copy of your license key number in a secure location. Please enter your license key numbers below for future reference. If you should lose your license key number, call your nearest Agilent Technologies service or sales office for assistance.

License Key Numbers for Instrument with Serial # _____
For Option _____ the license key number is _____
For Option _____ the license key number is _____
For Option _____ the license key number is _____
For Option _____ the license key number is _____
For Option _____ the license key number is _____
For Option _____ the license key number is _____

If you purchase an option later, you will receive a certificate that indicates the unique license key number that you will need to install that option on your particular serial number instrument.

NOTE

You will need to enter a license key number only if you purchase an additional measurement personality at a later date, or if you want to reactivate a measurement personality that has been deactivated.

Installing a License Key Number

NOTE

Follow this procedure to reinstall a license key number which has been deleted during the uninstall process, or lost due to a memory failure.

To install a license key number for the selected option, use the following procedure:

1. Press **System, Install, Choose Option**. The **Choose Option** key accesses the alpha editor menu. Use the alpha editor to enter letters (upper-case) and the front-panel numeric keys to enter numbers for the option designation. Then press the **Done** key. As you enter the option, you will see your entry in the active function area of the display.

Note: that you must already have entered the license key for the GSM option BAH before you can enter the license key for the EDGE retrofit option 252.

2. Press **License Key**. Use the alpha editor to enter letters and the front-panel numeric keys to enter digits. You will see your entry in the active function area of the display. When you have completed entering the license key number, press the **Done** key.

3. Press the **Install Now** key after you have entered the personality option number and the license key number. On some instruments, a message may appear in the function area of the display which reads, "Insert disk and power cycle the instrument". Disregard this message. If you want to proceed with the installation, press the **Yes** key and cycle the instrument power off and then on. Press the **No** key if you wish to cancel the installation process.

Using the Uninstall Key

The following procedure removes the license key number for the selected option. This will make the option unavailable for use, and the message "Application Not Licensed" will appear in the Status/Info bar at the bottom of the display. Please write down the 12-digit license key number for the option before proceeding. If that measurement personality is to be used at a later date you will need the license key number to reactivate the personality firmware.

NOTE

Using the Uninstall key does not remove the personality from the instrument memory, and does not free memory to be available to install another option. If you need to free memory to install another option, refer to the instructions for loading firmware updates located at the URL: www.agilent.com/find/vsa/

1. Press **System, More(1 of 3), More(2 of 3), Uninstall, Choose Option**. Pressing the **Choose Option** key will activate the alpha editor menu. Use the alpha editor to enter the letters (upper-case) and the front-panel numeric keyboard to enter the digits (if required) for the option, then press the **Done** key. As you enter the option, you will see your entry in the active function area of the display.
2. Press the **Uninstall Now** key after you have entered the personality option. Press the **Yes** key if you want to continue the uninstall process. Press the **No** key to cancel the uninstall process.
3. Cycle the instrument power off and then on to complete the uninstall process.

Setting Up the W-CDMA (Trial & Arib) Mode
Installing Optional Measurement Personalities

5

**Making W-CDMA (Trial & Arib)
Measurements**

W-CDMA (Trial & Arib) Measurements

Once in the W-CDMA (Trial & Arib) mode, the following measurements are available by pressing the **Measure** key:

- “Making the Channel Power Measurement” on page 200
- “Making the Adjacent Channel Power Ratio (ACPR) Measurement” on page 205
- “Making a Power Statistics CCDF Measurement” on page 213
- “Making the Code Domain Measurement” on page 218
- “Making the QPSK EVM Measurement” on page 232
- “Making the Modulation Accuracy (Rho) Measurement” on page 240
- “Making the Spectrum (Frequency Domain) Measurement” on page 248
- “Making the Waveform (Time Domain) Measurement” on page 256

These are referred to as one-button measurements. When you press the key to select one measurement it will become the active measurement, using settings and a display unique to that measurement. Data acquisitions will automatically begin when trigger requirements, if any, are met.

Preparing for Measurements

If you want to set the W-CDMA (Trial & Arib) mode to a known, factory default state, press **Preset**. This will preset the mode setup and all of the measurements to the factory default parameters. You should often be able to make a measurement using these defaults.

NOTE

Pressing the **Preset** key does not switch instrument modes.

To preset only the parameter settings that are specific to the selected measurement, press **Meas Setup, More (1 of 2), Restore Meas Defaults**. This will reset the measurement setup parameters, for the currently selected measurement only, to the factory defaults.

Initial Setup

Before making a measurement, make sure the mode setup and frequency channel parameters are set to the desired settings. Refer to the sections [“Changing the Mode Setup” on page 18](#) and [“Changing the Frequency Channel” on page 23](#).

Measurement Selection

The **Measure** front-panel key accesses the menu to select one of the following measurements:

- **Channel Power** - Press this key to make channel power measurements. This is the in-channel power measurement. The channel power graph is displayed in the graph window and both the absolute channel power and mean power spectral density are shown in the text window.
- **ACPR** - Press this key to make adjacent channel power ratio (ACPR) measurements. This is the out-of-channel measurement. The following displays are available:
 - Bar graph display to show a histogram of powers within the integration bandwidth
 - Spectrum display to show a power distribution curve, like a swept-frequency spectrum analyzer, relative to the center frequency power of the carrier signal
- **Power Stat CCDF** - Press this key to make power statistics, Complementary Cumulative Distribution Function (CCDF) measurements. This is helpful to observe the time domain characteristics of a spread spectrum signal that can significantly affect the ACPR measurement results for a given UUT.

- **Code Domain** - Press this key to make code domain power (CDP) measurements when **Standard** is set to either **Trial 1998** or **ARIB 1.0-1.2**, and also when **Device** is set to **BTS**. The amount of power in each code channel is displayed. The following displays are available:
 - Power graph and metrics to show the code domain power and the summary data
 - Quad view for the I/Q errors in graphs for the spread rate selected, and the summary data
 - Quad view for the code domain power, the selected symbol power vs. symbol rate, and the selected symbol EVM polar vector graphs, and the summary data
- **QPSK EVM** - Press this key to make QPSK error vector magnitude (EVM) measurements. The following displays are available:
 - Polar vector graph of the I/Q demodulated signal and the summary data
 - Polar constellation graph of the I/Q demodulated signal and the summary data
 - Quad view for the I/Q errors in graphs and the summary data
- **Mod Accuracy (Perch Only)** - Press this key to make modulation accuracy (rho) measurements when **Standard** is set to either **Trial 1998** or **ARIB 1.0-1.2**, and also when **Device** is set to **BTS**. The input signal should contain only the Perch channel. This is essentially a code domain power measurement with one active channel. The following displays are available:
 - Polar vector graph of the I/Q demodulated signal and the summary data
 - Polar constellation graph of the I/Q demodulated signal and the summary data
 - Quad view for the I/Q errors in graphs and the summary data
- **Spectrum (Freq Domain)** - Press this key to make frequency domain spectrum measurements. Spectrum and I/Q waveform displays are available.
- **Waveform (Time Domain)** - Press this key to make time domain waveform measurements. RF envelope and I/Q waveform displays are available.

Measurement Control

The **Meas Control** front-panel key accesses the menu to control processes that affect the running of the current measurement.

- **Restart** - Press this key to repeat the current measurement from the beginning, while retaining the current measurement settings. This is equivalent to the **Restart** front-panel key.
- **Measure** - Press this key (not to be confused with the **Measure** front-panel key which has a different function) to toggle the measurement state between **Single** and **Cont** (continuous). When set to **Single**, the measurement will continue until it has reached the specified number of averages set by the average counter. When set to **Cont**, the measurement will run continuously and execute averaging according to the current average mode, either repeat or exponential. The default setting is **Cont** excepting the code domain measurement which is defaulted to **Single**.
- **Pause** - Press this key to pause the current measurement until you reactivate the measurement. Once toggled, the label of the **Pause** key changes to read **Resume**. The **Resume** key, once pressed, continues the active measurement from the point at which it was paused.

Measurement Setup

The **Meas Setup** key accesses the features that enable you to adjust parameters of the current measurement, such as span and resolution bandwidth, according to the measurement function. You will also use the **Meas Setup** menu to access the **Average**, **Limit Test**, **Advanced** and other feature menus.

The following measure setup features can be used with many or all measurements:

- **Restore Meas Defaults** - Allows you to preset only the settings that are specific to the selected measurement by pressing **Meas Setup**, **More (1 of 2)**, **Restore Meas Defaults**. This will set the measure setup parameters, for the currently selected measurement only, to the factory defaults.

Averaging

Selecting one of the averaging keys in the **Meas Setup** menu will allow you to modify the average number and averaging mode you use for the currently selected measurement. For spectrum (frequency domain) and waveform (time domain) measurements the **Average** key activates the following menu:

- **Avg Number** - Allows you to change the number of N averages to be made.

- **Avg Mode** - Allows you to toggle the averaging mode between **Exp** (exponential) and **Repeat**. This selection only effects on the averaging result after the number of N averages is reached. The N is set using the **Avg Number** key.

Normal averaging: Normal (linear) averaging is always used until the specified number of N averages is reached. When the **Measure** key under **Meas Control** is set to **Single**, data acquisition is stopped when the number of N averages is reached, thus **Avg Mode** has no effect in the single measurement mode.

Exponential averaging: When **Measure** is set to **Cont**, data acquisition will continue indefinitely. Exponential averaging is used with a weighting factor of N (the displayed count of averages stops at N). Exponential averaging weights new data more heavily than old data, which allows tracking of slow-changing signals. The weighting factor N is set using the **Avg Number** key.

Repeat averaging: When **Measure** is set to **Cont**, data acquisition will continue indefinitely. After the number of N averages is reached, all previous result data is cleared and the average count displayed is set back to 1. This is equivalent to being in **Measure Single** and pressing the **Restart** key each time the single measurement finishes.

- **Avg Type** - Allows you to access the menu of the following average types only for making spectrum (frequency domain) and waveform (time domain) measurements:

Pwr Avg (RMS) - Executes the true power averaging which is equivalent to taking the rms of the voltage. This is the most accurate type.

Log-Pwr Avg (Video) - Simulates the traditional spectrum analyzer type of averaging by calculating the log of the power.

Voltage Avg - Executes the voltage averaging.

Maximum - Executes the maximum voltage averaging by capturing peak data.

Minimum - Executes the minimum voltage averaging.

Selecting a Trigger Source

Changing the selection in the **Trig Source** menu alters the trigger source for the selected measurement only. Not all of the selections are always available for all measurements. Also, some W-CDMA (Trial & Arib) measurements do not require a trigger. Choose one of the following trigger sources:

NOTE

The **RF Burst**, **Video (IF Envlp)**, **Ext Front** and **Ext Rear** keys found under the **Trigger** menu enable you to change the default settings of the delay, level and slope for each of these trigger sources.

- **Free Run (Immediate)** - A trigger occurs at the time the data is requested, completely asynchronous with the RF or IF signal.
- **Video (IF Envlp)** - An internal IF envelope trigger that occurs at the absolute threshold level of the IF signal level.
- **RF Burst (Wideband)** - An internal wideband RF burst trigger that has the automatic level control for burst signals. It triggers at the level that is set relative to the peak RF signal (12 MHz bandwidth) input level.
- **Ext Front** - Activates the front-panel external trigger input (**EXT TRIGGER INPUT**) port. The external signal must be between -5.00 and $+5.00$ V with 1 or 10 mV resolution.
- **Ext Rear** - Activates the rear-panel external trigger input (**TRIGGER IN**) port. The external signal must be between -5.00 and $+5.00$ V with 1 or 10 mV resolution.
- **Frame** - Uses the internal frame clock to generate a trigger signal. The clock parameters are controlled under the **Mode Setup** key or the measurement firmware, but not both. See the specific measurement for details.
- **Line** - Sets the trigger to the internal line mode. Sweep triggers occur at intervals synchronous to the line frequency. This trigger source is available for spectrum (frequency domain) and waveform (time domain) measurements.

Using the Trigger Outputs

The rear panel **TRIGGER 1 OUT** and **TRIGGER 2 OUT** connectors are coupled to the selected trigger source. These trigger outputs are always on at the rising edge with a pulse width of at least 1 μ s.

Making the Channel Power Measurement

Purpose

Channel power measurement is a common test used in the wireless industry to measure the total transmitted power of a radio within a defined frequency channel. This procedure measures the total power within the defined channel for W-CDMA. This measurement can be used to design, characterize, evaluate, and verify transmitters and components or devices for base stations and mobile stations.

Measurement Method

The channel power measurement reports the total power within the channel bandwidth, 4.096 MHz for the ARIB 1.0-1.2 and Trial 1998 modes or 3.840 MHz for the 3GPP mode. The transmitter tester acquires a number of points representing the input signal in the time domain. It transforms this information into the frequency domain using FFT and then calculates the channel power. The effective resolution bandwidth of the frequency domain trace is proportional to the number of points acquired for FFT. The fastest FFT process is achieved using a number of acquired points that is a power of 2 (for example: 64, 128, 512).

Since the measurement is optimized for speed and accuracy, you are permitted to change only the number of acquired data points in powers of 2, not the actual resolution bandwidth. However, if absolute sweep time is required, sweep time can be changed to the user's specified time at the expense of reduced speed. At no time will both sweep time and data points be set to manual because of conflicting parameter settings. This flexibility is available through the **Advanced** menu of the channel power measurement.

To improve repeatability, you can increase either the number of averages or the number of data points with longer time record length. The channel power graph is shown in the graph window and the absolute channel power in dBm and the mean power spectral density in dBm/Hz are shown in the text window.

Making the Measurement

NOTE

The factory default settings provide a good starting point. For special requirements, you may need to change some of the settings. Press **Meas Setup, More (1 of 2), Restore Meas Defaults** at any time to return all parameters for the current measurement to their default settings.

Select the desired center frequency as described in [“Changing the Frequency Channel” on page 23](#).

Press **Measure, Channel Power** to immediately make a channel power measurement.

To change any of the measurement parameters from the factory default values, refer to [“Changing the Measurement Setup” on page 202](#) for this measurement.

Results

The next figure shows an example result of Channel Power measurements. The channel power graph is shown in the graph window. The absolute channel power and its mean power spectral density are shown in the text window.

Figure 5-1

Channel Power Measurement

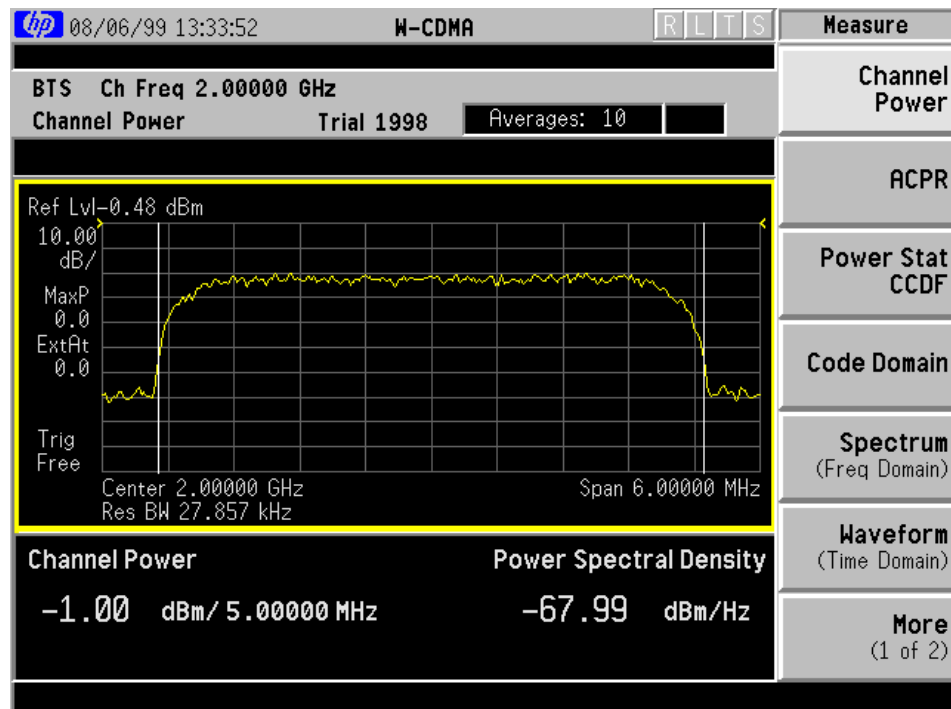

Changing the Measurement Setup

The next table shows the factory default settings for channel power measurements.

Table 5-1 Channel Power Measurement Defaults

Measurement Parameter	Factory Default Condition
Meas Setup:	
Avg Number	10, On
Avg Mode	Repeat
Integ BW ^a	5.00000 MHz
Chan Power Span ^a	6.00000 MHz
Advanced	
Sweep Time	17.07 μ s, Auto ^b
Data Points	512, Auto ^b
Trig Source	Free Run (Immediate)

- a. The Integ BW setting proportionally changes the Chan Pwr Span setting up to 10 MHz.
- b. These are mutually interlinked to be set to either Man/Auto or Auto/Man.

NOTE Parameters under the **Advanced** key seldom need to be changed. Any changes from the factory default values may result in invalid measurement data.

Make sure the **Channel Power** measurement is selected under the **Measure** menu. The **Meas Setup** key accesses the menu which allows you to modify the average number and average mode for this measurement as described in [“Measurement Setup” on page 197](#).

The following parameters can be changed according to your measurement requirement:

- **Integ BW** - Allows you to specify the integration bandwidth in which the power is measured. The range is 1.000 kHz to 10.0000 MHz with 1 or 10 Hz resolution. Since **Integ BW** is coupled to **Chan Pwr Span** in the factory default condition, if you change the integration bandwidth setting, the channel power span setting changes by a proportional amount until a limit value is reached.
- **Chan Power Span** - Allows you to set the frequency span for the channel power measurement. The range is 1.000 kHz to 10.0000 MHz with 1 or 10 Hz resolution. This span is used for the current integration bandwidth setting. Since **Chan Power Span** is coupled to **Integ BW** in the factory default condition, if you change the integration bandwidth setting, the channel power span setting changes by a proportional amount, 1.2 times the integration bandwidth, until a limit value is reached. However, the channel power span can be individually set.

In addition, the following parameters for channel power measurements can be modified by pressing the **Advanced** key:

- **Sweep Time** - Allows you to toggle the sweep time control between **Auto** and **Man** (manual), and also to manually change the sweep time if set to **Man**. The range is 1.000 μ s to 50.00 ms with 1 or 10 μ s resolution. If set to **Auto**, the sweep time derived from the data points setting is shown on this key label regardless of the manual entry range.
- **Data Points** - Allows you to toggle the data point control between **Auto** and **Man** (manual), and also to manually change the data points if set to **Man**. The range is 64 to 65536 with the acceptable entry in powers of 2 (for example: 64, 128, 512). If set to **Auto**, the data point derived from the sweep time setting is shown on this key label regardless of the manual entry range.
- **Res BW** - Shows information on the resolution bandwidth derived from the sweep time.
- **Trig Source** - Allows you to change the trigger source from free run (immediate) to the external input signal supplied to either **Ext Front** or **Ext Rear** port.

Changing the Display

The **Amplitude Y Scale** key accesses the menu to set the desired vertical scale and associated parameters.

- **Scale/Div** - Allows you to enter a numeric value to change the vertical display sensitivity. The range is 0.10 to 20.00 dB with 0.01 dB resolution. The default setting is 10.00 dB, however, since **Scale Coupling** is defaulted to **On**, this value is automatically determined by the measurement result.
- **Ref Value** - Allows you to enter a numeric value to change the absolute power value as the display reference. The range is -250.00 to 250.00 dBm with 0.01 dB resolution. The default setting is 10.00 dBm, however, since **Scale Coupling** is defaulted to **On**, this value is automatically determined by the measurement result.
- **Ref Position** - Allows you to set the display reference position to either **Top**, **Ctr** (center), or **Bot** (bottom). The default setting is **Top**.
- **Scale Coupling** - Allows you to toggle the scale coupling function between **On** and **Off**. The default setting is **On**. This function automatically determines the scale per division and reference values by the measurement results.

Troubleshooting Hints

If an external attenuator is used, be sure to include its attenuation in the measurement of the channel power. Use the **Ext Atten** key.

The channel power measurement can reveal degraded or defective parts in the transmitter section of the UUT. The following examples are those areas to be checked further.

- Some faults in the DC power supply control of the transmitter power amplifier, RF power controller of the pre-power amplifier stage, and/or I/Q control of the baseband stage.
- Some degradation in the gain and output power level of the amplifier due to the degraded gain control and/or increased distortion.
- Some degradation of the amplifier linearity and other performance characteristics.

Power amplifiers are one of the final stage elements of a base or mobile transmitter and are a critical part of meeting the important power and spectral efficiency specifications. Since the channel power measurement measures the spectral response of the amplifier to a complex wideband signal, it is a key measurement linking amplifier linearity and other performance characteristics to the stringent system specifications.

Making the Adjacent Channel Power Ratio (ACPR) Measurement

Purpose

Adjacent Channel Power Ratio (ACPR), as it applies to W-CDMA, is the power contained in a specified frequency channel bandwidth relative to the total carrier power. It may also be expressed as a ratio of power spectral densities between the carrier and the specified offset frequency.

As a composite measurement of out-of-channel emissions, ACPR combines both in-band and out-of-band specifications to provide useful figures-of-merit for spectral regrowth and emissions produced by components and circuit blocks without the rigor of performing a full spectrum emissions mask measurement.

Measurement Method

The ACPR measurement measures up to five pairs of offset channels and relates them to the carrier power. An integration bandwidth (IBW) method is used to measure the carrier channel power and offset powers.

The IBW method performs a time domain data acquisition and applies FFT to get a frequency domain trace. In this process, the channel integration bandwidth is analyzed using the automatically defined resolution bandwidth (RBW), which is much narrower than the channel bandwidth. The measurement computes an average power of the channel over a specified number of data acquisitions, automatically compensating for resolution bandwidth and noise bandwidth.

This measurement requires the user to specify measurement bandwidths of the carrier channel and each of the offset frequency pairs up to 5. Each pair may be defined with unique measurement bandwidths. The results are displayed both as relative power in dBc, and as absolute power in dBm.

Making the Measurement

NOTE

The factory default settings provide a good starting point. For special requirements, you may need to change some of the settings. Press **Meas Setup, More (1 of 2), Restore Meas Defaults** at any time to return all parameters for the current measurement to their default settings.

Select the desired center frequency as described in [“Changing the Frequency Channel” on page 23](#).

Press **Measure, ACPR** to immediately make an adjacent channel power ratio (ACPR) measurement.

To change any of the measurement parameters from the factory default values, refer to [“Changing the Measurement Setup” on page 207](#).

Results

The next figure shows an example result of ACPR-FFT Bar Graph (Total Pwr Ref) measurements in the graph window. The absolute and relative power levels on both sides of the carrier frequency are displayed in the text window.

Figure 5-2

ACPR Measurement - FFT Bar Graph View

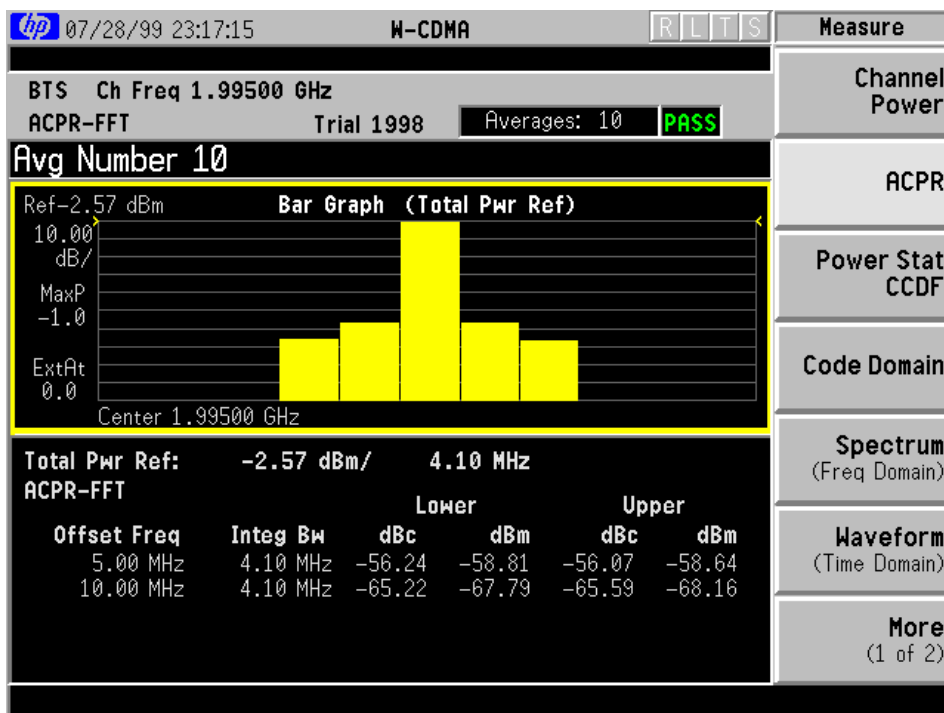

Changing the Measurement Setup

The next table shows the factory default settings for adjacent channel power ratio measurements.

Table 5-2 Adjacent Channel Power Ratio Measurement Defaults

Measurement Parameter	Factory Default Condition
View/Trace	FFT Bar Graph (Total Pwr Ref)
Meas Setup:	
Avg Number	10, On
Avg Mode	Repeat
Chan Integ BW: for ARIB & Trial 1998	4.09600 MHz
for 3GPP	3.84000 MHz
Ofs & Limits:	
Offset	A
Offset Freq:	
A	5.00000 MHz, On
B	10.0000 MHz, On
C	15.0000 MHz, Off
D	20.0000 MHz, Off
E	25.0000 MHz, Off
Ref BW: A to E	
for ARIB & Trial 1998	4.09600 MHz
for 3GPP	3.84000 MHz
Abs Limit: A to E	50.00 dBm
Fail: A to E	Relative
Rel Lim (Car): A to E	0.00 dBc
Rel Lim (PSD): A to E	0.00 dB
Meas Type	Total Pwr Ref
Sweep Type	FFT
Advanced	
Swp Acq Time (if Sweep Type is Swp)	625.0 μ s

Make sure the **ACPR** measurement is selected under the **Measure** menu. The **Meas Setup** key accesses the menu which allows you to modify the average number and average mode for this measurement as described in “[Measurement Setup](#)” on page 197. In addition, the following parameters for adjacent channel power ratio measurements can be modified.

- **Chan Integ BW** - Allows you to specify the channel integration bandwidth in which the carrier power is measured. The range is 300.000 kHz to 20.0000 MHz with 1 Hz resolution.
- **Ofs & Limits** - Allows you to access the menu to change the following parameters for offset frequency settings and pass/fail tests:

Offset - Allows you to access the memory selection menu from **A** to **E** to store 5 sets of values for **Offset Freq**, **Ref BW**, **Abs Limit** and so forth. Only one selection at a time (A, B, C, D, or E) is shown on this key label.

Offset Freq - Allows you to enter an offset frequency value, and to toggle the offset frequency function between **On** and **Off**, according to each offset key selected. The range is 0.0 Hz to 100.000 MHz. While this key is activated, enter an offset frequency value from the numeric keypad by terminating with one of the frequency unit keys shown. One offset frequency value selected from the **Offset** menu is shown on this key label.

Ref BW - Allows you to enter a reference bandwidth ranging from 1.000 kHz to 20.0000 MHz with 1 Hz resolution. When this parameter is changed, the integration bandwidth **Integ BW** in the summary data window changes to that value.

Abs Limit - Allows you to enter an absolute limit value ranging from -200.00 to +50.00 dBm with 0.01 dB resolution.

Fail - Allows you to access the following menu to select one of the logic keys for fail conditions between the measurement results and the test limits:

AND - Fail is shown if one of the relative ACPR measurement results is larger than **Rel Lim (Car)** or **Rel Lim (PSD)** AND one of the absolute ACPR measurement results is larger than **Abs Limit**.

OR - Fail is shown if one of the relative ACPR measurement results is larger than **Rel Lim (Car)** or **Rel Lim (PSD)** OR one of the absolute ACPR measurement results is larger than **Abs Limit**.

Absolute - Fail is shown if one of the absolute ACPR measurement results is larger than **Abs Limit**.

Relative - Fail is shown if one of the relative ACPR measurement results is larger than **Rel Lim (Car)** or **Rel Lim (PSD)**.

Rel Lim (Car) - Allows you to enter a relative limit value of the carrier level ranging from -200.00 to $+50.00$ dBc with 0.01 dB resolution.

Rel Lim (PSD) - Allows you to enter a relative limit value of the power spectral density level ranging from -200.00 to $+50.00$ dB with 0.01 dB resolution.

- **Meas Type** - Allows you to access the menu to select one of the measurement reference types.

Total Pwr Ref - Sets the reference to the total carrier power and the measured data is shown in dBc and dBm.

PSD Ref - Sets the reference to the mean power spectral density of the carrier and the measured data is shown in dB and dBm/Hz.

- **Sweep Type** - Allows you to toggle the sweep type between **FFT** and **Swp** (swept). If set to **Swp**, the measurement is made by the swept spectrum method like the traditional swept frequency spectrum analysis to have better correlation to the input signal with a high crest factor (peak/average ratio). However, it may take a longer time. Also, only the **Spectrum** view is available.
- **Swp RBW** - Allows you to enter the sweep resolution bandwidth, and to toggle this function between **Auto** and **Man** (manual), when **Sweep Type** is set to **Swp**. If set to **Auto**, the sweep resolution bandwidth is set automatically, according to the sweep span derived from **Offset Freq** and **Ref BW**. If set to **Man**, the sweep resolution bandwidth is manually changed. The range is 1.000 kHz to 1.00000 MHz with 1 Hz resolution. The default setting is 41.667 kHz and **Auto**.
- **Swp Det** - Allows you to toggle the sweep detector type between **Avg** (average) and **Peak**, when **Sweep Type** is set to **Swp**. The default selection is **Peak**.
- **Advanced** - Allows you to access the menu to set the following parameter:
 - Swp Acq Time** - Allows you to set the data acquisition time when **Sweep Type** is set to **Swp**. The range is 500.0 μ s to 10.00 ms with 1 μ s resolution.

Changing the View

The **View/Trace** key accesses the menu to select the desired view of the measurement result as follows when **Sweep Type** is set to **FFT**. When **Sweep Type** is set to **Swp**, the **Bar Graph** key is not available only to show the spectrum display.

- **Bar Graph** - In the factory default condition, 5 of the total integration power levels, centered at the carrier frequency and ± 5.0 MHz and ± 10.0 MHz offset frequencies, are shown in the graph window. The corresponding measured data is shown in the text window as shown in [Figure 5-2 on page 206](#). Depending on the **Meas Type** setting, one of the two following displays is obtained:
 - Bar Graph (Total Pwr Ref) - A histogram of powers referenced to the total carrier power
 - Bar Graph (PSD Ref) - A histogram of powers referenced to the mean power spectral density of the carrier in dBm/Hz

- **Spectrum** - In the factory default condition, the frequency spectrum with the FFT sweep type is displayed with the bandwidth marker lines in the graph window. The corresponding measured data in the text window is the total integration power levels within the defined bandwidth as shown in the figure below.

Figure 5-3 ACPR Measurement - FFT Spectrum View

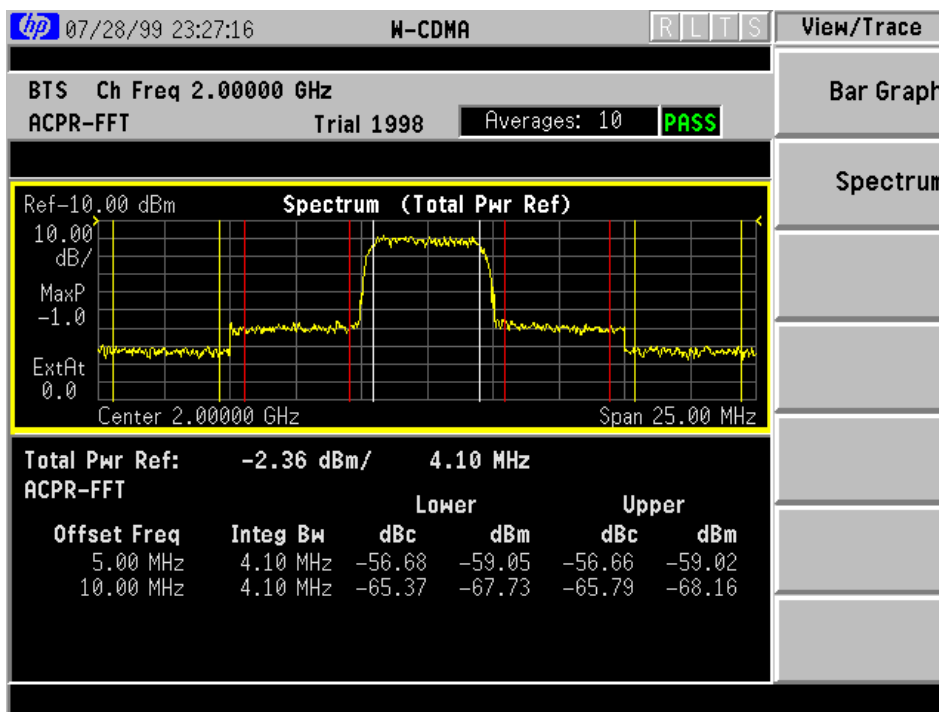

Depending on the **Meas Type** setting, one of the two following displays is obtained with either **FFT** or **Swp** mode:

Spectrum (Total Pwr Ref) - A spectrum display referenced to the total carrier power

Spectrum (PSD Ref) - A spectrum display referenced to the mean power spectral density of the carrier in dBm/Hz

NOTE

If **Sweep Type** is set to **FFT**, the spectrum graph does not show the actual power level measured at each of the offsets. Select **Swp** for the more accurate spectrum graph.

While in this view, you can change the vertical scale by pressing the **Amplitude Y Scale** key. You can also activate or deactivate the reference bandwidth markers and the spectrum grid by pressing the **Display** key.

Changing the Display

When the spectrum graph window is selected, the **Amplitude Y Scale** key accesses the menu to set the desired measurement scale and associated parameters:

- **Scale/Div** - Allows you to enter a numeric value to change the vertical display sensitivity. The range is 0.10 to 20.00 dB with 0.01 dB resolution. The default setting is 10.00 dB, however, since the **Scale Coupling** is defaulted to **On**, this value is automatically determined by the measurement result.
- **Ref Value** - Allows you to set the absolute power reference value ranging from -250.00 to 250.00 dBm with 0.01 dB resolution. The default setting is 10.00 dBm, however, since the **Scale Coupling** is defaulted to **On**, this value is automatically determined by the measurement result.
- **Ref Position** - Allows you to set the reference position to either **Top**, **Ctr** (center), or **Bot** (bottom). The default setting is **Top**.
- **Scale Coupling** - Allows you to toggle the scale coupling function between **On** and **Off**. The default setting is **On**. This function automatically determines the scale per division and reference values by the measurement results.

The **Display** key also accesses the menu to control the markers on the display as follows:

- **Ref BW Markers** - Allows you to toggle the reference bandwidth markers function between **On** and **Off**. If set to **On**, the line markers with the reference bandwidth are shown on the measurement result display.

Troubleshooting Hints

If an external attenuator is used, be sure to include its attenuation in the ACPR measurement. Use the **Ext Atten** key.

This adjacent channel power ratio measurement can reveal degraded or defective parts in the transmitter section of the UUT. The following examples are those areas to be checked further.

- Some faults in the DC power supply control of the transmitter power amplifier, RF power controller of the pre-power amplifier stage, or I/Q control of the baseband stage
- Some degradation in the gain and output power level of the amplifier due to the degraded gain control and/or increased distortion
- Some degradation of the amplifier linearity and other performance characteristics

Power amplifiers are one of the final stage elements of a base or mobile transmitter and are a critical part of meeting the important power and spectral efficiency specifications. Since ACPR measures the spectral response of the amplifier to a complex wideband signal, it is a key measurement linking amplifier linearity and other performance characteristics to the stringent system specifications.

Making a Power Statistics CCDF Measurement

Purpose

Many of the digitally modulated signals now look noise-like in the time and frequency domain. This means that statistical measurements of the signals can be a useful characterization. Power Complementary Cumulative Distribution Function (CCDF) curves characterize the higher level power statistics of a digitally modulated signal. The curves can be useful in determining design parameters for digital communications systems.

The power statistics CCDF measurement can be affected by many factors. For example, modulation filtering, modulation format, combining the multiple signals at different frequencies, number of active codes and correlation between symbols on different codes with spread spectrum systems. These factors are all related to modulation and signal parameters. External factors such as signal compression and expansion by non-linear components, group delay distortion from filtering, and power control within the observation interval also affect the measurement.

Measurement Method

The power measured in power statistics CCDF curves is actually instantaneous envelope power defined by the equation:

$$P = (I^2 + Q^2) / Z_0$$

(where I and Q are the quadrature voltage components of the waveform and Z_0 is the characteristic impedance).

A CCDF curve is defined by how much time the waveform spends at or above a given power level. The percent of time the signal spends at or above the level defines the probability for that particular power level. To make the power statistics CCDF measurement, the transmitter tester uses digital signal processing (DSP) to sample the input signal in the channel bandwidth.

The Gaussian distribution line as the band-limited gaussian noise CCDF reference line, the user-definable reference trace, and the currently measured trace can be displayed on a semi-log graph. If the currently measured trace is above the user reference trace, it means that the higher peak power levels against the average power are included in the input signal.

Making the Measurement

NOTE The factory default settings provide a good starting point. For special requirements, you may need to change some of the settings. Press **Meas Setup, More (1 of 2), Restore Meas Defaults** at any time to return all parameters for the current measurement to their default settings.

Select the desired center frequency as described in [“Changing the Frequency Channel” on page 23](#).

Press **Measure, Power Stat CCDF** to immediately make a power statistics CCDF measurement.

To change any of the measurement parameters from the factory default values, refer to [“Changing the Measurement Setup” on page 215](#).

Results

The next figure shows an example result of Power Stat CCDF measurements in the graph window. The average power and its probability are shown in the text window.

Figure 5-4

Power Statistics CCDF Measurement

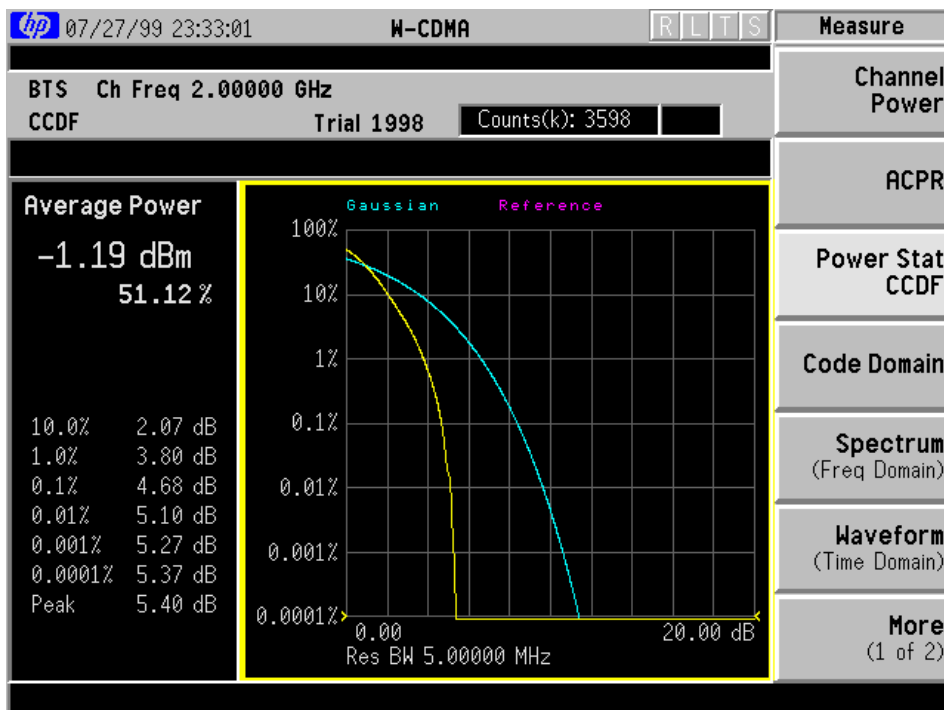

Changing the Measurement Setup

The next table shows the factory default settings for power statistics CCDF measurements.

Table 5-3 Power Statistics CCDF Measurement Defaults

Measurement Parameter	Factory Default Condition
Meas Setup:	
Meas BW	5.00000 MHz
Counts	10.0000 Mpoints
Meas Interval	1.000 ms
Trig Source	Free Run (Immediate)
Display:	
Ref Trace	Off
Gaussian Line	On

Make sure the **Power Stat CCDF** measurement is selected under the **Measure** menu. Press the **Meas Setup** key to access the menu which allows you to modify the trigger source for this measurement as described in “[Measurement Setup](#)” on page 197. In addition, the following parameters can be modified.

- **Meas BW** - Allows you to set the measurement bandwidth according to the channel bandwidth. The range is 10.000 kHz to 6.70000 MHz with 0.1 kHz resolution.
- **Counts** - Allows you to set the accumulated number of sampling points for data acquisition. The range is 1.000 kpoints to 2.000 Gpoints with 1 or 10 kpoints resolution. While this key is activated, enter a value from the numeric keypad by terminating with one of the unit keys shown.
- **Meas Interval** - Allows you to specify the time interval over which the measurement is made. The range is 100.0 μ s to 10.00 ms with 1 μ s resolution.

Changing the View

The **View/Trace** key is not available for this measurement.

Changing the Display

The **Display** key allows you to control the desired trace and line displays of the power statistics CCDF curves. The currently measured curve is always shown.

- **Store Ref Trace** - Allows you to copy the currently measured curve as the user-definable reference trace. The captured data will remain until the other mode is chosen. Pressing this key refreshes the reference trace.
- **Ref Trace** - Allows you to toggle the reference trace display function between **On** and **Off**.
- **Gaussian Line** - Allows you to toggle the Gaussian line display function between **On** and **Off**.

The **Span X Scale** key accesses the menu to set the desired horizontal scale.

- **Scale/Div** - Allows you to enter a numeric value to change the horizontal display sensitivity. The range is 0.10 to 20.00 dB with 0.01 dB resolution. The default setting is 2.00 dB.

Using the Markers

The **Marker** front-panel key accesses the menu to configure the markers.

- **Select** - Allows you to activate up to four markers with the corresponding numbers, respectively. The selected number is underlined and its function is defined by pressing the **Function** key. The default selection is 1.
- **Normal** - Allows you to activate the selected marker to read the power level and probability of the marker position on the selected curve, for example, which is controlled by the RPG knob.
- **Delta** - Allows you to read the differences in the power levels and probabilities between the selected marker and the next.
- **Function** - Allows you to set the selected marker function to **Band Power**, **Noise**, or **Off**. The default setting is **Off**. The **Band Power** and **Noise** functions are not available for this measurement.
- **Trace** - Allows you to place the selected marker on the **Measured**, **Gaussian**, or **Reference** curve. The default setting is **Measured**.
- **Off** - Allows you to turn off the selected marker.
- **Shape** - Allows you to access the menu to set the selected marker shape to **Diamond**, **Line**, **Square**, or **Cross**. The default setting is **Diamond**.
- **Marker All Off** - Allows you to turn off all of the markers.

Troubleshooting Hints

The power statistics CCDF measurement can contribute in setting the signal power specifications for design criteria for systems, amplifiers, and other components. For example, it can help determine the optimum operating point to adjust each code timing for appropriate peak/average power ratio throughout the wide channel bandwidth of the transmitter for a W-CDMA system.

As this measurement is a new method, there will be some correlations between CCDF curve degradation and digital radio system measurement parameters such as BER, FER, code domain power, and ACPR. Some studies will help set standards for radio design by specifying the maximum allowed CCDF curve degradation for specific systems.

Making the Code Domain Measurement

Purpose

Since the code domain measurements despread and decode the W-CDMA signal into its physical channels, the number of active channels of various symbol rates (which are denoted by widths) can be observed. The width of the channel is inversely proportional to the Orthogonal Variable Spreading Factor (OVSF) code length in number of bits. In the code domain, there is a fixed amount of code space for a given chip rate. Therefore, by using the different OVSF codes, the system can dynamically allocate the code space for lower rate voice users versus high speed data users.

This code domain power composite view provides information about the in-channel characteristics of the W-CDMA signal. It directly informs the user of the active channels with their individual channel powers. The composite view also shows which data rates are active and the corresponding amount of code space used. The following are conditions under which a general unlock can occur: the Perch signal is too low in power or no Perch signal available, an incorrect long code is used for despreading, the frequency error is too large, or a frequency inversion is present.

When the level of the code domain noise floor is too high, relative to a reference or an expected level, one of the possible causes might be due to CW interference, like local oscillator feedthrough or spurs. I/Q modulation impairments can be another source of this uncorrelated noise. The I/Q demodulation measurements can reveal errors such as I/Q gain imbalance or I/Q quadrature error.

Measurement Method

This procedure measures the power levels of the spread channels in a single RF channel when **Standard** in the **Radio** menu is set to **ARIB 1.0-1.2** or **Trial 1998**, and also when **Device** is set to **BTS**. One uniqueness from other measurements is that **Measure** in the **Meas Control** menu is defaulted to **Single**.

The code domain measurement displays the power for each of the spread channels, relative to the total power within the 4.096 MHz channel bandwidth centered at the center frequency. Each spread channel level is displayed as an individual vertical bar with a different width determined by a spread rate. Because this is a relative measurement, the unit of measure is dB (not dBm or watts). This allows a comparison of signal levels between the Perch and Traffic channels.

The following displays are available for this measurement:

- **Power Graph & Metrics** - The transmitted energy associated with each of the symbol rates and codes is shown in the graph window. The following powers along with the total power are shown in the text window:
 - Total active channel power
 - Perch channel power
 - Number of active channels
 - Maximum active channel power
 - Average active channel power
 - Maximum inactive channel power
 - Average inactive channel power
- **I/Q Error (Quad View)** - The magnitude error, phase error, and EVM graphs are shown in the graph window. The summary data for these parameters are also shown in the text window.
- **Code Domain (Quad View)** - The graphs of the code domain power, the symbol power for the selected spread channel, and the symbol EVM polar vector for the symbol power range selected by the measurement interval and measurement offset parameters, are shown in the graph windows. The summary data is also shown in the text window.

Making the Measurement

NOTE

The factory default settings provide a good starting point. For special requirements, you may need to change some of the settings. Press **Meas Setup, More (1 of 2), Restore Meas Defaults** at any time to return all parameters for the current measurement to their default settings.

Select the desired center frequency as described in [“Changing the Frequency Channel” on page 23](#).

Press **Measure, Code Domain** to immediately make a code domain power measurement.

To change any of the measurement parameters from the factory default values, refer to [“Changing the Measurement Setup” on page 221](#).

Results

The next figure shows an example result of Code Domain Power measurements. In the graph window, the active channel symbol rates are shown with those widths of the bars and the measured channel powers are shown with those heights. Also, the summary data are shown in the text window.

Figure 5-5

Code Domain Measurement - Power Graph View

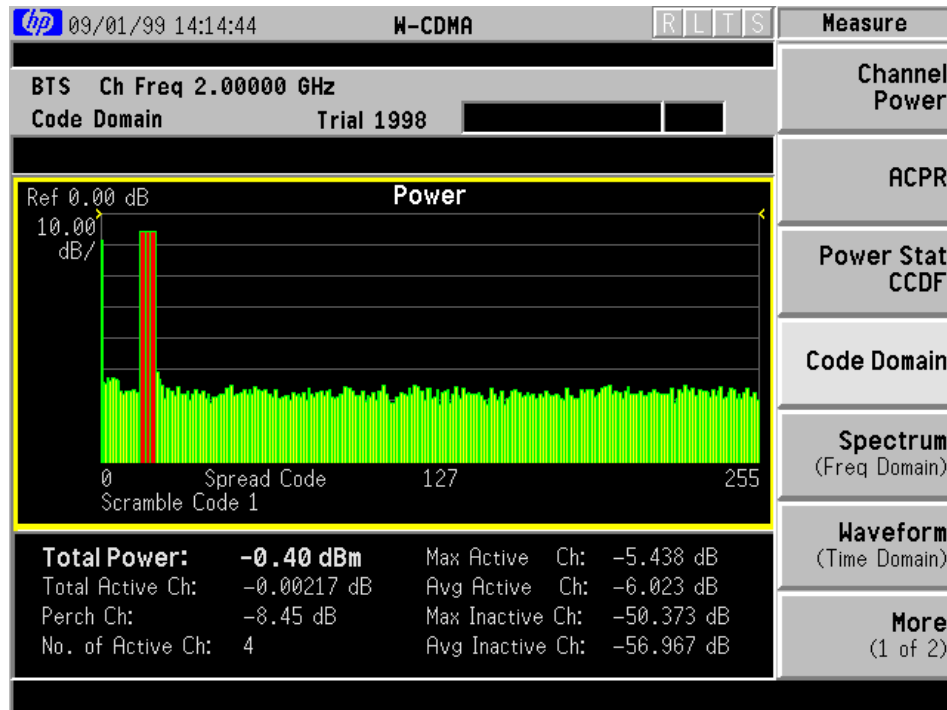

Changing the Measurement Setup

The next table shows the factory default settings for code domain power measurements.

Table 5-4 Code Domain Power Measurement Defaults

Measurement Parameter	Factory Default Condition
View/Trace	Power Graph & Metrics
Meas Setup:	
Symbol Rate	16 ksps
Code Number	0
Meas Interval	1 slots
Meas Offset	0 slots
Scramble Code	1
Trig Source	Free Run (Immediate)
Spectrum	Normal
Meas Control:	
Measure	Single
Advanced	
Power Offset: (for ARIB only) Ref Set	Auto
Alpha	0.220
Chip Rate	4.09600 MHz

Make sure the **Code Domain** measurement is selected under the **Measure** menu. Press the **Meas Setup** key to access the menu which allows you to modify the trigger source for this measurement as described in [“Measurement Setup” on page 197](#). Also, press the **Meas Control** key to access the menu which allows you to change **Measure** from single to continuous as described in [“Measurement Control” on page 197](#). In addition, the following parameters can be modified.

- **Symbol Rate** - Allows you to set the symbol rate ranging from 8 to 1024 ksps. The parameter automatically sets the maximum value for **Code Number** when appropriate. If **Symbol Rate** is set to 16 ksps and **Code Number** is set to 0, the Perch channel is automatically selected as the channel type. When the channel type is set to Perch, the search code portion is not included in the symbol EVM calculation. In other cases, the channel type is set to DPCH which enables power offset measurements.

- **Code Number** - Allows you to set the code number. The range is 0 to 511 depending on the **Symbol Rate** setting as follows:

Symbol Rate	Code Number	Description
8 ksps	0 to 511	Not available for Trial 1998
16 ksps	0 to 255	
32 ksps	0 to 127	
:	:	
512 ksps	0 to 7	
1024 ksps	0 to 3	

- **Meas Interval** - Allows you to set the time interval in slots over which the symbol EVM measurement is made. The range is 32 to 1 slots in conjunction with the **Meas Offset** value. The maximum value is 32 minus the **Meas Offset** value. The marker lines of which width varies with this number of slots are displayed in the symbol power graph of the **Code Domain (Quad View)** display.
- **Meas Offset** - Allows you to set the number of offset slots to make the symbol EVM measurement. The range is 0 to 31 slots in conjunction with the **Meas Interval** value. The maximum value is 32 minus the **Meas Interval** value. The marker lines shift to right by this number of slots in the symbol power graph of the **Code Domain (Quad View)** display.
- **Scramble Code** - Allows you to enter a hexadecimal value for the scramble code. Pressing this key reveals the keys labeled **A** to **F** and **Done**. The range is 0000 to 3FFFF. Use the numeric keypad and these keys to create a hexadecimal value by terminating with the **Done** key.
- **Spectrum** - Allows you to toggle the spectrum function between **Normal** and **Invert**. This key, when set to **Invert**, conjugates the spectrum, which equivalently negates the quadrature component in demodulation. The correct setting (**Normal** or **Invert**) depends on whether the signal being given to the transmitter tester has a high or low side mix.

- **Advanced** - Allows you to access the menu to set the following parameters.

Power Offset - Allows you to access the menu with the following parameters. (This key is not available for the Trial 1998 mode.)

Ref Set - Allows you to toggle the power offset reference setting function between **Auto** and **Man** (manual). If set to **Auto**, the symbol EVM is computed with the measured average power for that power region. If set to **Man**, the symbol EVM is computed with the measured average power for data plus the power offset specified.

PO1 (Pilot) - Allows you to specify the power offset value of the pilot bits. The range is -20.00 to $+50.00$ dB with 0.01 dB resolution.

PO2 (TPC) - Allows you to specify the power offset value of the transmit power control bits. The range is -20.00 to $+50.00$ dB with 0.01 dB resolution.

PO3 (TFCI) - Allows you to specify the power offset value of the transport format control indicator bits. The range is -20.00 to $+50.00$ dB with 0.01 dB resolution.

Alpha - Allows you to specify the alpha value of the root-raised cosine filter. The range is 0.01 to 0.50.

Chip Rate - Allows you to change the chip rate. The range is 3.68640 to 4.50560 MHz.

Changing the View

The **View/Trace** key will allow you to select the desired view of the measurement from the following. Each of these views contains multiple windows that can be selected using the **Next Window** key and made full size using the **Zoom** key.

- **Power Graph & Metrics** - Provides a combination view of the code domain power graph and the summary data as shown in [Figure 5-5 on page 220](#).
- **I/Q Error (Quad View)** - Provides a combination view of the magnitude error, phase error, EVM graphs, and the summary data.

Figure 5-6 Code Domain Measurement - I/Q Error Quad View

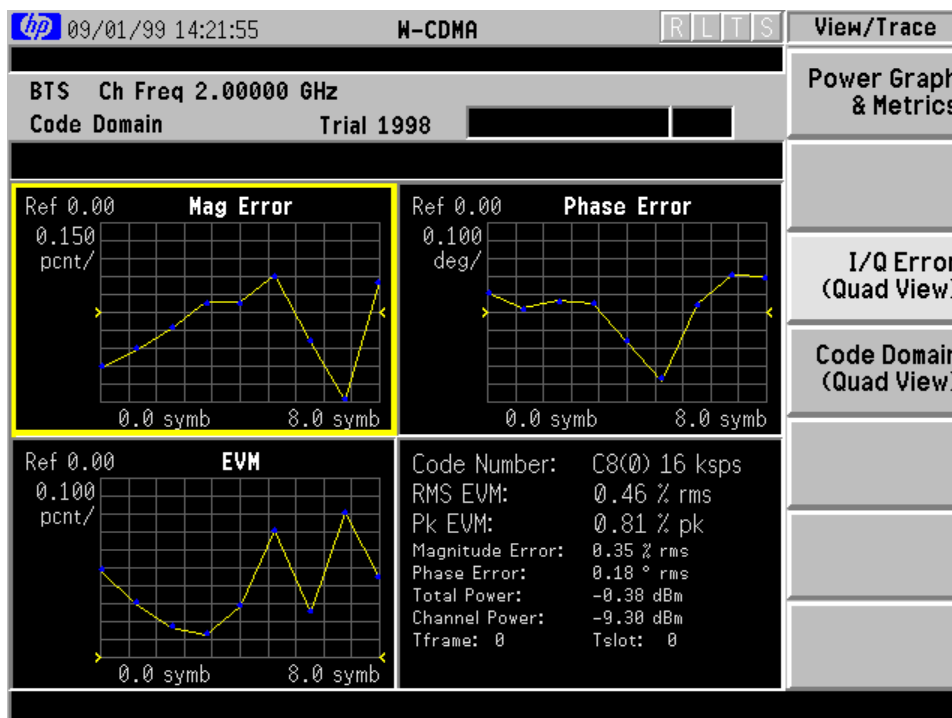

- **Code Domain (Quad View)** - Provides a combination view of the code domain power, symbol power, symbol EVM polar vector graphs, and the summary data.

Figure 5-7 Code Domain Measurement - Code Domain Quad View

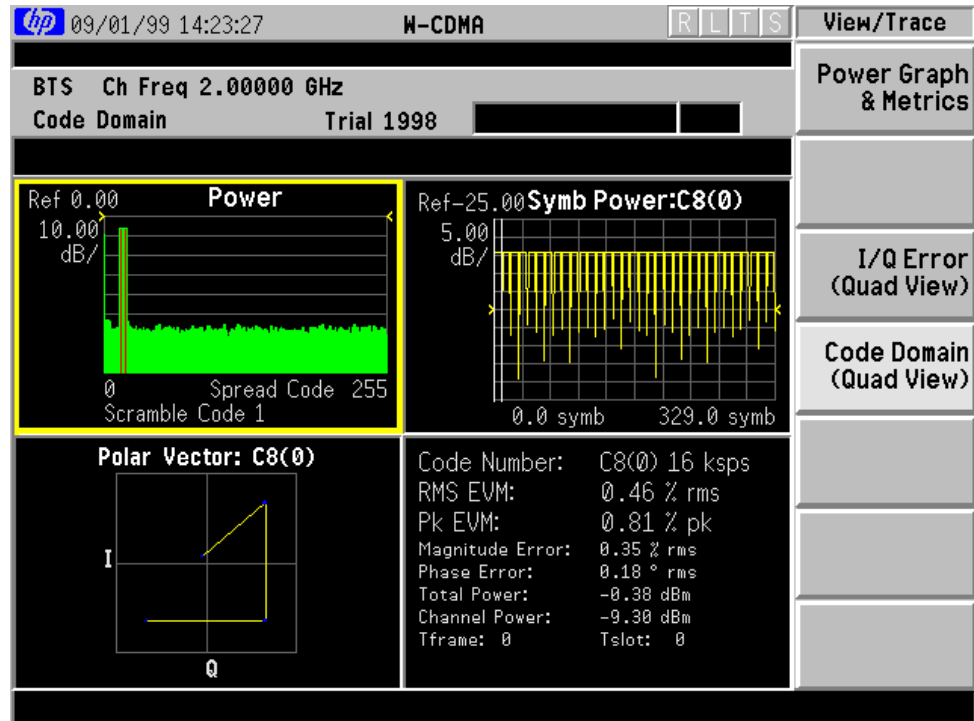

While the Code Domain Power graph is activated, press the **Marker** key to place a marker on any active spread channel. Then, press the **Mkr->Despread** key to observe the Symbol Power and the Symbol EVM Polar Vector graphs with the spread code number for that active channel in other graph windows. The symbol EVM polar vector graph is displayed for the symbol power specified by the measurement interval and measurement offset.

Changing the Display

The **Display** key is not available for the code domain measurement because there is no meaning in phase trajectories between constellation points for symbol EVM measurements. Therefore, the points per chip is always set to 1 and **Chip Dots** is set to On.

- While the **Power Graph & Metrics** display is selected, the **Span X Scale** and **Amplitude Y Scale** keys access the menus to allow the following settings:

— The **Span X Scale** key accesses the following menu:

Scale/Div - Allows you to set the horizontal scale by changing a spread code value. The range is 64.00 to 256.0 (for Trial 1998), or to 512.0 (for ARIB 1.0-1.2), spread codes with 0.01 or 0.1 spread code resolution. The default setting is 256.0 (for Trial 1998), or 512.0 (for ARIB 1.0-1.2), spread codes.

Ref Value - Allows you to set the spread code reference value. The range is 0.000 to 192.0 (for Trial 1998), or to 448.0 (for ARIB 1.0-1.2), spread codes with the scale at least 64 spread codes. The default setting is 0.000 spread code.

Ref Position - Allows you to set the reference position to either **Left**, **Ctr** (center) or **Right**. The default setting is **Left**.

Expand - Allows you to toggle the expanding function of the code domain power graph between **On** and **Off**. If set to **On**, the CDP graph is expanded horizontally to show 64 spread codes centered at the scale or the marker position. Upon toggling back to **Off**, the spread code range returns to the previous setting.

— The **Amplitude Y Scale** key accesses the following menu:

Scale/Div - Allows you to set the vertical scale by changing the value per division. The range is 0.10 to 20.0 dB per division. The default setting is 5.00 dB, however, since **Scale Coupling** is defaulted to **On**, this value is automatically determined by the measurement result.

Ref Value - Allows you to set the reference value ranging from -250.00 to 250.00 dB. The default setting is 0.00 dB, however, since **Scale Coupling** is defaulted to **On**, this value is automatically determined by the measurement results.

Ref Position - Allows you to set the reference position to either **Top**, **Ctr** (center) or **Bot** (bottom). The default setting is **Top**.

Scale Coupling - Allows you to toggle the scale coupling function between **On** and **Off**. The default setting is **On**. This function automatically determines the scale per division and reference values by the measurement results.

- While the **I/Q Error (Quad-View)** display is selected, the **Span X Scale** and **Amplitude Y Scale** keys access the menus to allow the following settings depending on the active window.
 - If either **EVM**, **Phase Error**, or **Mag Error** window is active, the **Span X Scale** key accesses the following menu:
 - Scale/Div** - Allows you to set the horizontal scale by changing a symbol value per division. The range is 1.00 to 100.00 symbols per division with 0.01 symbol resolution. The default setting is 1.900 symbols, however, since **Scale Coupling** is defaulted to **On**, this value is automatically determined by the measurement result.
 - Ref Value** - Allows you to set the symbol reference value ranging from 0.00 to 1000.0 symbols. The default setting is 0.00 symbol, however, since **Scale Coupling** is defaulted to **On**, this value is automatically determined by the measurement results.
 - Ref Position** - Allows you to set the reference position to either **Left**, **Ctr** (center) or **Right**. The default setting is **Left**.
 - Scale Coupling** - Allows you to toggle the scale coupling function between **On** and **Off**. The default setting is **On**. This function automatically determines the scale per division and reference values by the measurement results.
 - If either **EVM** or **Mag Error** window is active, the **Amplitude Y Scale** key accesses the following menu:
 - Scale/Div** - Allows you to set the vertical scale by changing the value per division. The range is 0.100 to 50.0% per division. The default setting is 5.00%, however, since **Scale Coupling** is defaulted to **On**, this value is automatically determined by the measurement result.
 - Ref Value** - Allows you to set the reference value ranging from -500.00 to 500.0%. The default setting is 0.00%, however, since **Scale Coupling** is defaulted to **On**, this value is automatically determined by the measurement results.
 - Ref Position** - Allows you to set the reference position to either **Top**, **Ctr** (center) or **Bot** (bottom). For the **EVM** graph, the default setting is **Bot**. For the **Mag Error** graph, the default setting is **Ctr**.
 - Scale Coupling** - Allows you to toggle the scale coupling function between **On** and **Off**. The default setting is **On**. This function automatically determines the scale per division and reference values by the measurement results.

- If the `Phase Error` window is active, the **Amplitude Y Scale** key accesses the following menu:

Scale/Div - Allows you to set the vertical scale by changing the value per division. The range is 0.0100 to 3600.0 degrees. The default setting is 5.00 degrees, however, since **Scale Coupling** is defaulted to **On**, this value is automatically determined by the measurement result.

Ref Value - Allows you to set the reference value ranging from -36000.0 to 36000.0 degrees. The default setting is 0.00 degrees, however, since **Scale Coupling** is defaulted to **On**, this value is automatically determined by the measurement results.

Ref Position - Allows you to set the reference position to either **Top**, **Ctr** (center) or **Bot** (bottom). The default setting is **Ctr**.

Scale Coupling - Allows you to toggle the scale coupling function between **On** and **Off**. The default setting is **On**. This function automatically determines the scale per division and reference values by the measurement results.

- While the **Code Domain (Quad-View)** display is selected, the **Span X Scale** and **Amplitude Y Scale** keys access the menus to allow the following settings depending on the active window.

- If the `Code Domain Power` window is active, the **Span X Scale** key accesses the following menu:

Scale/Div - Allows you to set the horizontal scale by changing a spread code value. The range is 64.00 to 256.0 (for Trial 1998), or to 512.0 (for ARIB 1.0-1.2), spread codes with 0.01 or 0.1 spread code resolution. The default setting is 256.0 (for Trial 1998), or 512.0 (for ARIB 1.0-1.2), spread codes.

Ref Value - Allows you to set the spread code reference value. The range is 0.000 to 192.0 (for Trial 1998), or to 448.0 (for ARIB 1.0-1.2), spread codes with the scale at least 64 spread codes. The default setting is 0.000 spread code.

Ref Position - Allows you to set the reference position to either **Left**, **Ctr** (center) or **Right**. The default setting is **Left**.

Expand - Allows you to toggle the expanding function of the code domain power graph between **On** and **Off**. If set to **On**, the CDP graph is expanded horizontally to show 64 spread codes centered at the scale or the marker position. Upon toggling back to **Off**, the spread code range returns to the previous setting.

- If `Symbol Power` window is active, the **Span X Scale** key accesses the following menu:

Scale/Div - Allows you to set the horizontal scale by changing a symbol value per division. The range is 1.000 to 100.0 symbols per division with 0.01 symbol resolution. The default setting is 11.90 symbols, however, since **Scale Coupling** is defaulted to **On**, this value is automatically determined by the measurement result.

Ref Value - Allows you to set the symbol reference value ranging from 0.000 to 1000.0 symbols. The default setting is 0.000 symbol, however, since **Scale Coupling** is defaulted to **On**, this value is automatically determined by the measurement results.

Ref Position - Allows you to set the reference position to either **Left**, **Ctr** (center) or **Right**. The default setting is **Left**.

Scale Coupling - Allows you to toggle the scale coupling function between **On** and **Off**. The default setting is **On**. This function automatically determines the scale per division and reference values by the measurement results.

- If `Code Domain Power` window is active, the **Amplitude Y Scale** key accesses the following menu:

Scale/Div - Allows you to set the vertical scale by changing the value per division. The range is 0.10 to 20.0 dB per division. The default setting is 5.00 dB, however, since **Scale Coupling** is defaulted to **On**, this value is automatically determined by the measurement result.

Ref Value - Allows you to set the reference value ranging from -250.00 to 250.00 dB. The default setting is 0.00 dB, however, since **Scale Coupling** is defaulted to **On**, this value is automatically determined by the measurement results.

Ref Position - Allows you to set the reference position to either **Top**, **Ctr** (center) or **Bot** (bottom). The default setting is **Top**.

Scale Coupling - Allows you to toggle the scale coupling function between **On** and **Off**. The default setting is **On**. This function automatically determines the scale per division and reference values by the measurement results.

- If the `Symbol Power` window is active, the **Amplitude Y Scale** key accesses the following menu:

Scale/Div - Allows you to set the vertical scale by changing the value per division. The range is 0.10 to 20.00 dB. The default setting is 5.00 dB, however, since **Scale Coupling** is defaulted to **On**, this value is automatically determined by the measurement result.

Ref Value - Allows you to set the reference value ranging from -250.00 to 250.00 dB. The default setting is 0.00 dB, however, since **Scale Coupling** is defaulted to **On**, this value is automatically determined by the measurement results.

Ref Position - Allows you to set the reference position to either **Top**, **Ctr** (center) or **Bot** (bottom). The default setting is **Ctr**.

Scale Coupling - Allows you to toggle the scale coupling function between **On** and **Off**. The default setting is **On**. This function automatically determines the scale per division and reference values by the measurement results.

Using the Markers

The **Marker** front-panel key accesses the menu to configure the markers depending on the display selected.

- **Select** - Allows you to activate up to four markers with the corresponding numbers, respectively. The selected number is underlined and its function is defined by pressing the **Function** key. The default setting is 1.
- **Normal** - Allows you to activate the selected marker to read the power level and symbol code with the code layer of the marker position, for example, which is controlled by the RPG knob.
- **Delta** - Allows you to read the differences in the power levels and symbols codes between the selected marker and the next.
- **Function** - Allows you to set the selected marker function to **Band Power**, **Noise**, or **Off**. The default setting is **Off**. The **Band Power** and **Noise** functions are not available for this measurement.
- **Trace** - Allows you to place the selected marker on the **Code Domain Power**, **Symbol Power**, **EVM**, **Phase Error**, or **Mag Error** trace. The default setting is **Code Domain Power**.
- **Off** - Allows you to turn off the selected marker.
- **Shape** - Allows you to access the menu to set the selected marker shape to **Diamond**, **Line**, **Square**, or **Cross**. The default setting is **Diamond**.
- **Marker All Off** - Allows you to turn off all of the markers.
- **Mkr→Despread** - While a marker is set on any active spread channel of the code domain power graph in **Code Domain (Quad View)**, allows you to observe the **Symbol Power** and the **Symbol EVM Polar Vector** graphs with the spread code number for that active channel in other graph windows. The symbol EVM polar vector graph is displayed for the symbol power specified by the measurement interval and measurement offset.

Troubleshooting Hints

Uncorrelated interference may cause CW interference like local oscillator feedthrough or spurs. Another uncorrelated noise may be due to I/Q modulation impairments. Correlated impairments can be due to the phase noise on the local oscillator in the upconverter or I/Q modulator of the UUT. These will be analyzed by the code domain measurements along with the QPSK EVM measurements and others.

A poor phase error indicates a problem at the I/Q baseband generator, filters, and/or modulator in the transmitter circuitry of the UUT. The output amplifier in the transmitter can also create distortion that causes unacceptably high phase error. In a real system, a poor phase error will reduce the ability of a receiver to correctly demodulate the received signal, especially in marginal signal conditions.

Making the QPSK EVM Measurement

Purpose

Phase and frequency errors are measures of modulation quality for the W-CDMA system. This modulation quality is obtained through QPSK Error Vector Magnitude (EVM) measurements. Since the W-CDMA system uses the Quadrature Phase Shift Keying (QPSK) modulation technique, the phase and frequency accuracies of the transmitter are critical to the communications system performance and ultimately affect range.

W-CDMA receivers rely on the phase and frequency quality of the QPSK modulation signal in order to achieve the expected carrier to noise ratio. A transmitter with high phase and frequency errors will often still be able to support phone calls during a functional test. However, it will tend to provide difficulty for mobiles trying to maintain service at the edge of the cell with low signal levels or under difficult fading and Doppler conditions.

Measurement Method

The phase error of the unit under test is measured by computing the difference between the phase of the transmitted signal and the phase of a theoretically perfect signal.

The instrument samples the transmitter output in order to capture the actual phase trajectory. This is then demodulated and the ideal phase trajectory is mathematically derived using detected bits and root-raised cosine channel filtering. Subtracting one from the other results in a phase error signal.

This measurement allows you to display these errors numerically and graphically on the instrument display. There are graphs for EVM, Phase Error and Mag Error in the graph windows. In the text window, there are both maximum and average data for Evm: in % rms, in % peak, RMS Mag Error: in %, Phase Error: in degrees, Freq Error: in Hz, and IQ Offset: in dB.

Making the Measurement

NOTE

The factory default settings provide a good starting point. For special requirements, you may need to change some of the settings. Press **Meas Setup, More (1 of 2), Restore Meas Defaults** at any time to return all parameters for the current measurement to their default settings.

Select the desired center frequency as described in [“Changing the Frequency Channel” on page 23](#).

Press **Measure, QPSK EVM** to immediately make a QPSK error vector magnitude (EVM) measurement.

To change any of the measurement parameters from the factory default values, refer to [“Changing the Measurement Setup” on page 234](#).

Results

The next figure shows an example result of I/Q Measured Polar Vector for the QPSK EVM measurements in the graph window. The measured values for EVM and other parameters are shown in the text window.

Figure 5-8

QPSK EVM Measurement - Polar Vector View

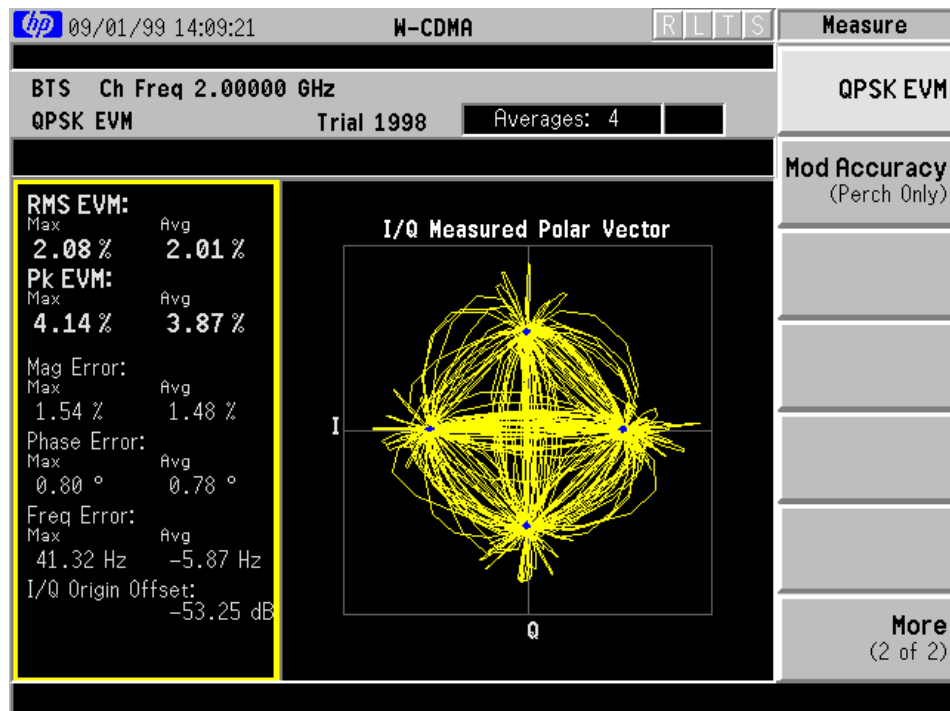

Changing the Measurement Setup

The next table shows the factory default settings for QPSK EVM measurements.

Table 5-5 QPSK EVM Measurement Defaults

Measurement Parameter	Factory Default Condition
View/Trace	I/Q Measured Polar Vector
Meas Setup:	
Avg Number	10, On
Avg Mode	Repeat
Meas Interval	256 chips
Trig Source	Free Run (Immediate)
Advanced	
Alpha	0.220
Chip Rate:	
for ARIB & Trial 1998	4.09600 MHz
for 3GPP	3.84000 MHz

Make sure the **QPSK EVM** measurement is selected under the **Measure** menu. Press the **Meas Setup** key to access the menu which allows you to modify the average number, average mode, and trigger source as described in “[Measurement Setup](#)” on page 197. In addition, the following QPSK error vector magnitude measurement parameters can be modified.

- **Meas Interval** - Allows you to set the time interval over which the measurement is made. The range is 128 to 512 chips.
- **Advanced** - Allows you to access the menu to change the following parameters:

Alpha - Allows you to change the alpha value of the root-raised cosine filter. The range is 0.01 to 0.50.

Chip Rate - Allows you to change the chip rate. The range is 3.68640 to 4.50560 MHz for ARIB 1.0-1.2 and Trial 1998, or 3.45600 to 4.22400 MHz for 3GPP.

Changing the View

The **View/Trace** key will allow you to select the desired view of the measurement from the following:

- **I/Q Measured Polar Vector** - Provides a combination view of an I/Q measured polar vector graph and the maximum and average summary data as shown in [Figure 5-8 on page 233](#).
- **I/Q Measured Polar Constln** - Provides a combination view of an I/Q measured polar constellation graph and the maximum and average summary data as shown below.

Figure 5-9 QPSK EVM Measurement - Polar Constellation View

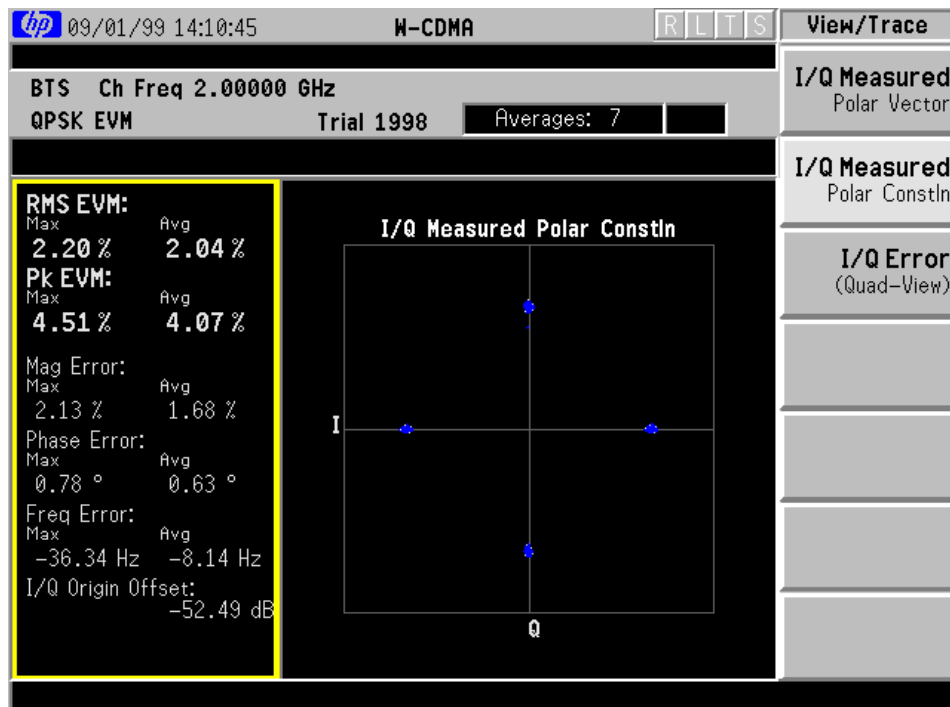

- **I/Q Error (Quad-View)** - Four display windows show Mag Error, Phase Error and EVM graphs and the maximum and average EVM summary data in the text window as shown below.

Figure 5-10 QPSK EVM Measurement - I/Q Error Quad View

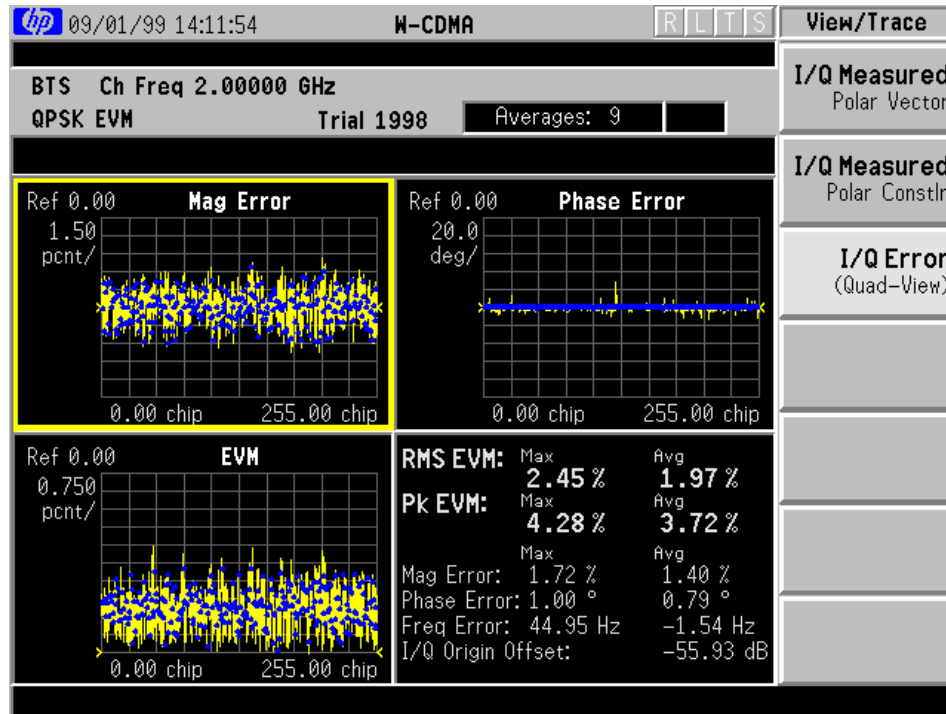

Any of these windows can be selected using the **Next Window** key and made full size using the **Zoom** key.

Changing the Display

The **Display** key accesses the menu to allow the following selections for changing the graph displays of I/Q Measured Polar Vector, I/Q Measured Polar Constellation and I/Q Error (Quad-View):

- **I/Q Points** - Allows you to specify the number of displayed chips for the I/Q waveforms. The range is 1 to 2560 points with the points per chip fixed to 5, depending on the **Meas Interval** setting. The default setting is 1280 points.
- **Chip Dots** - Allows you to toggle the chip dot display between **On** and **Off**. The default setting is **On**.
- **+45 Degree Rotation** - Allows you to toggle the display rotation function between **On** and **Off**. If this is set to **On**, the I/Q polar constellation graph is rotated by +45 degrees to see a rectangular display. The default setting is **Off**.

When either **EVM**, **Phase Error**, or **Mag Error** window is active in the **I/Q Error (Quad-View)** display, the **Span X Scale** key accesses the menu to allow the following settings:

- **Scale/Div** - Allows you to set the horizontal scale by changing a chip value per division. The range is 1.00 to 512.00 chips per division with 0.01 chip resolution. The default setting is 25.50 chips per division, however, since **Scale Coupling** is defaulted to **On**, this value is automatically determined by the measurement result.
- **Ref Value** - Allows you to set the chip reference value ranging from 0.000 to 1000.0 chips. The default setting is 0.000 chip, however, since **Scale Coupling** is defaulted to **On**, this value is automatically determined by the measurement results.
- **Ref Position** - Allows you to set the reference position to either **Left**, **Ctr** (center) or **Right**. The default setting is **Left**.
- **Scale Coupling** - Allows you to toggle the scale coupling function between **On** and **Off**. The default setting is **On**. This function automatically determines the scale per division and reference values by the measurement results.

When either **EVM** or **Mag Error** window is active in the **I/Q Error (Quad-View)** display, the **Amplitude Y Scale** key accesses the menu to allow the following settings:

- **Scale/Div** - Allows you to set the vertical scale by changing the value per division. The range is 0.100 to 50.0% per division. The default setting is 5.00%, however, since **Scale Coupling** is defaulted to **On**, this value is automatically determined by the measurement result.
- **Ref Value** - Allows you to set the reference value ranging from 0.00 to 500.0%. The default setting is 0.00%, however, since **Scale Coupling** is defaulted to **On**, this value is automatically determined by the measurement results.
- **Ref Position** - Allows you to set the reference position to either **Top**, **Ctr** (center) or **Bot** (bottom). For the **EVM** graph, the default setting is **Bot**. For the **Mag Error** graph, the default setting is **Ctr**.
- **Scale Coupling** - Allows you to toggle the scale coupling function between **On** and **Off**. The default setting is **On**. This function automatically determines the scale per division and reference values by the measurement results.

When the `Phase Error` window is active in the `I/Q Error (Quad-View)` display, the `Amplitude Y Scale` key accesses the menu to allow the following settings:

- **Scale/Div** - Allows you to set the vertical scale by changing the value per division. The range is 0.01 to 3600 degrees. The default setting is 5.00 degrees per division, however, since **Scale Coupling** is defaulted to **On**, this value is automatically determined by the measurement result.
- **Ref Value** - Allows you to set the reference value ranging from -36000 to 36000 degrees. The default setting is 0.00 degrees, however, since **Scale Coupling** is defaulted to **On**, this value is automatically determined by the measurement results.
- **Ref Position** - Allows you to set the reference position to either **Top**, **Ctr** (center) or **Bot** (bottom). The default setting is **Ctr**.
- **Scale Coupling** - Allows you to toggle the scale coupling function between **On** and **Off**. The default setting is **On**. This function automatically determines the scale per division and reference values by the measurement results.

Using the Markers

The **Marker** front-panel key accesses the menu to configure the markers depending on the display selected.

- **Select** - Allows you to activate up to four markers with the corresponding numbers, respectively. The selected number is underlined and its function is defined by pressing the **Function** key. The default setting is 1.
- **Normal** - Allows you to activate the selected marker to read the magnitude or phase error and the number of chips of the marker position on the selected trace, for example, which is controlled by the **RPG** knob.
- **Delta** - Allows you to read the differences in the magnitude or phase errors and the number of chips between the selected marker and the next.
- **Function** - Allows you to set the selected marker function to **Band Power**, **Noise**, or **Off**. The default setting is **Off**. The **Band Power** and **Noise** functions are not available for this measurement.
- **Trace** - Allows you to place the selected marker on the **EVM**, **Phase Error**, or **Mag Error** trace. The default setting is **EVM**.
- **Off** - Allows you to turn off the selected marker.
- **Shape** - Allows you to access the menu to set the selected marker shape to **Diamond**, **Line**, **Square**, or **Cross**. The default setting is **Diamond**.
- **Marker All Off** - Allows you to turn off all of the markers.

Troubleshooting Hints

A poor phase error indicates a problem at the I/Q baseband generator, filters, and/or modulator in the transmitter circuitry of the UUT. The output amplifier in the transmitter can also create distortion that causes unacceptably high phase error. In a real system, a poor phase error will reduce the ability of a receiver to correctly demodulate the received signal, especially in marginal signal conditions.

Making the Modulation Accuracy (Rho) Measurement

Purpose

Rho is one of the key modulation quality metrics, along with EVM and code domain power. Rho is the ratio of the correlated power in a single coded channel to the total signal power. This is a simplified case of code domain power since this measurement is made on a single coded channel. This measurement takes into account all possible error mechanisms in the entire transmission chain including baseband filtering, I/Q modulation anomalies, filter amplitude and phase non-linearities, and power amplifier distortions. This provides an overall indication of the performance level of the transmitter of the UUT.

Measurement Method

This procedure is to measure the performance of the transmitter's modulation circuitry when **Standard** in the **Radio** menu is set to **ARIB 1.0-1.2** or **Trial 1998**, and when **Device** is set to **BTS**.

In a digitally modulated signal, it is possible to predict, based on the transmitted data sequence, what the ideal magnitude and phase of the carrier should be at any time. The transmitter's modulated signal is compared to an ideal signal vector. The difference between these two vectors is sampled and processed using DSP. Rho values are in the range of 0 to 1. A value of 1 indicates perfect correlation to the reference (high modulation quality). The W-CDMA base station modes require that transmitters have a Rho performance of 0.912 or greater.

With the Rho measurement, the following data is provided:

- Rho - modulation quality representing the ratio of the correlated power in a single coded channel to the total signal power
- Frequency Error - the frequency difference between the transmitter's actual center frequency and the frequency (or channel) that you entered
- EVM - peak and rms Error Vector Magnitude
- Mag Error - rms Magnitude Error
- Phase Error - rms Phase Error
- I/Q Origin Offset

Making the Measurement

NOTE The factory default settings provide a good starting point. For special requirements, you may need to change some of the settings. Press **Meas Setup, More (1 of 2), Restore Meas Defaults** at any time to return all parameters for the current measurement to their default settings.

Select the desired center frequency as described in [“Changing the Frequency Channel” on page 23](#).

Press **Measure, Mod Accuracy (Rho)** to immediately make a modulation accuracy measurement.

To change any of the measurement parameters from the factory default values, refer to [“Changing the Measurement Setup” on page 242](#).

Results

The next figure shows an example result of I/Q Measured Polar Vector (Full Slot) for the modulation accuracy measurements in the graph window. The measured values for Rho, EVM, and other parameters are shown in the text window.

Figure 5-11 Modulation Accuracy Measurement - Polar Vector View

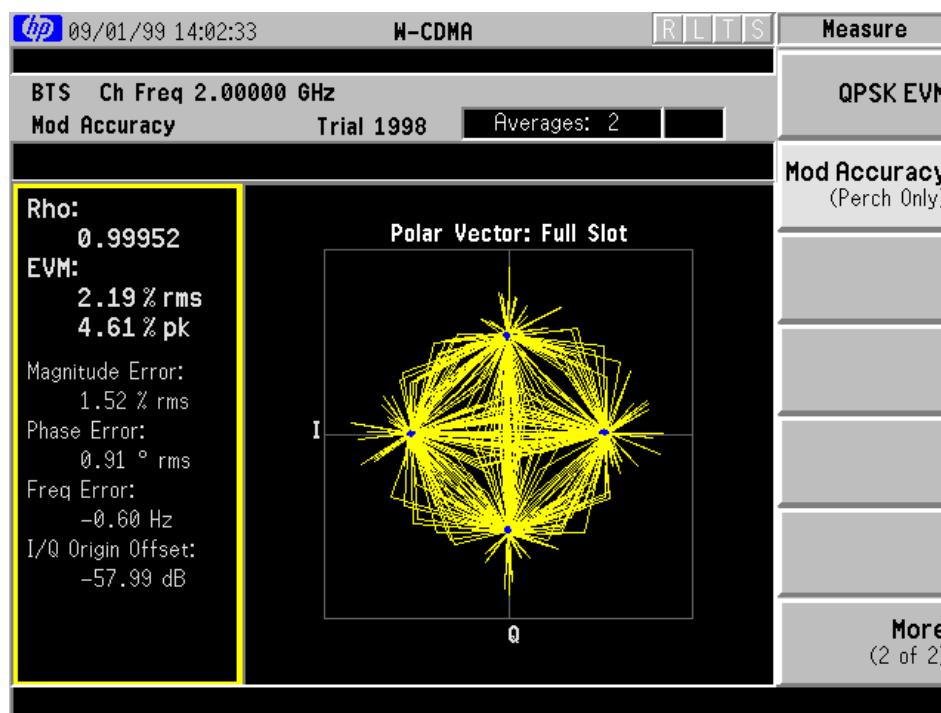

Changing the Measurement Setup

The next table shows the factory default settings for modulation accuracy (rho) measurements.

Table 5-6 Modulation Accuracy (Rho) Measurement Defaults

Measurement Parameter	Factory Default Condition
View/Trace	I/Q Measured Polar Vector
Meas Setup:	
Avg Number	10, On
Avg Mode	Repeat
Trig Source	Free Run (Immediate)
Scramble Code	1
Spectrum	Normal
Advanced	
Alpha	0.220
Chip Rate	4.09600 MHz

Make sure the **Mod Accuracy (Rho)** measurement is selected under the **Measure** menu. Press the **Meas Setup** key to access a menu which allows you to modify the average number, average mode, and trigger source as described in “[Measurement Setup](#)” on page 197. Since the rho is always calculated from the whole Perch slot with 2304 chips excepting the search code symbol, there is no need to set the measurement interval in this measurement. In addition, the following modulation accuracy measurement parameters can be modified.

- **Scramble Code** - Allows you to enter a hexadecimal value for the scramble code. Pressing this key reveals the keys labeled **A** to **F** and **Done**. The range is 0000 to 3FFFF. Use the numeric keypad and these keys to create a hexadecimal value and terminate with the **Done** key.
- **Spectrum** - Allows you to toggle the spectrum function between **Normal** and **Invert**. This key, when set to **Invert**, conjugates the spectrum, which equivalently negates the quadrature component in demodulation. The correct setting (**Normal** or **Invert**) depends on whether the signal being given to the transmitter tester has a high or low side mix.

- **Advanced** - Allows you to access the menu to change the following parameters:

Alpha - Allows you to change the alpha value of the root-raised cosine filter. The range is 0.01 to 0.50.

Chip Rate - Allows you to change the chip rate ranging from 3.68640 to 4.50560 MHz.

Changing the View

The **View/Trace** key will allow you to select the desired measurement view from the following selections:

- **I/Q Measured Polar Vector (Full Slot)** - Provides a combination view of an I/Q measured polar vector graph and the summary data as shown in [Figure 5-11 on page 241](#).
- **I/Q Measured Polar Constln (Full Slot)** - Provides a combination view of an I/Q measured polar constellation graph and the summary data as shown below.

Figure 5-12 Modulation Accuracy Measurement - Polar Constellation View

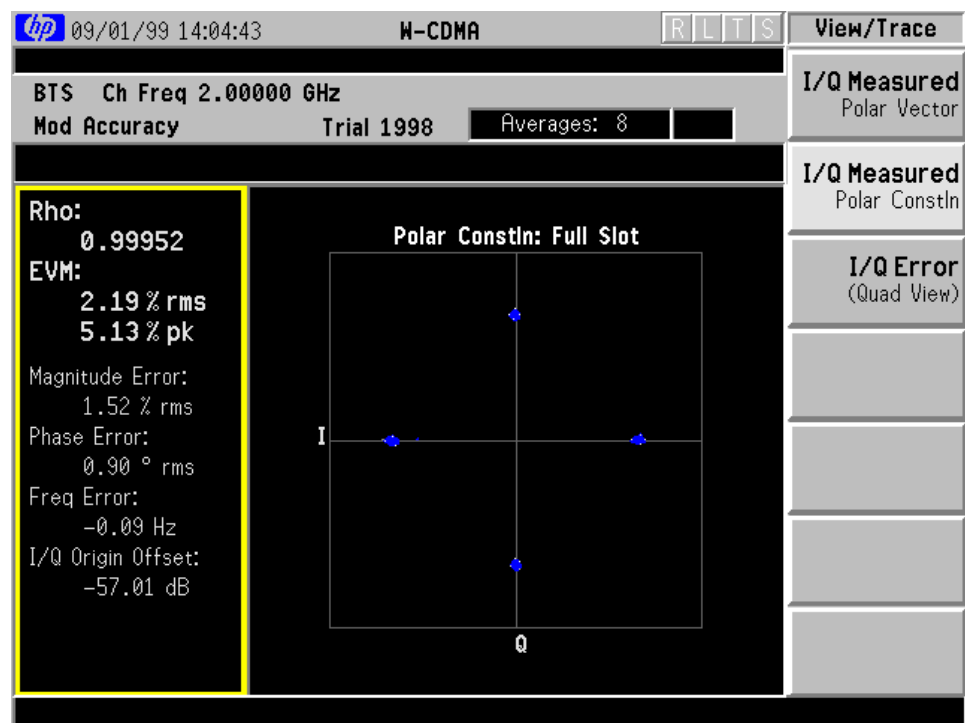

- **I/Q Error (Quad-View)** - Four display windows show Mag Error, Phase Error, and EVM graphs, and the modulation accuracy summary data as shown below.

Figure 5-13 Modulation Accuracy Measurement - I/Q Error Quad View

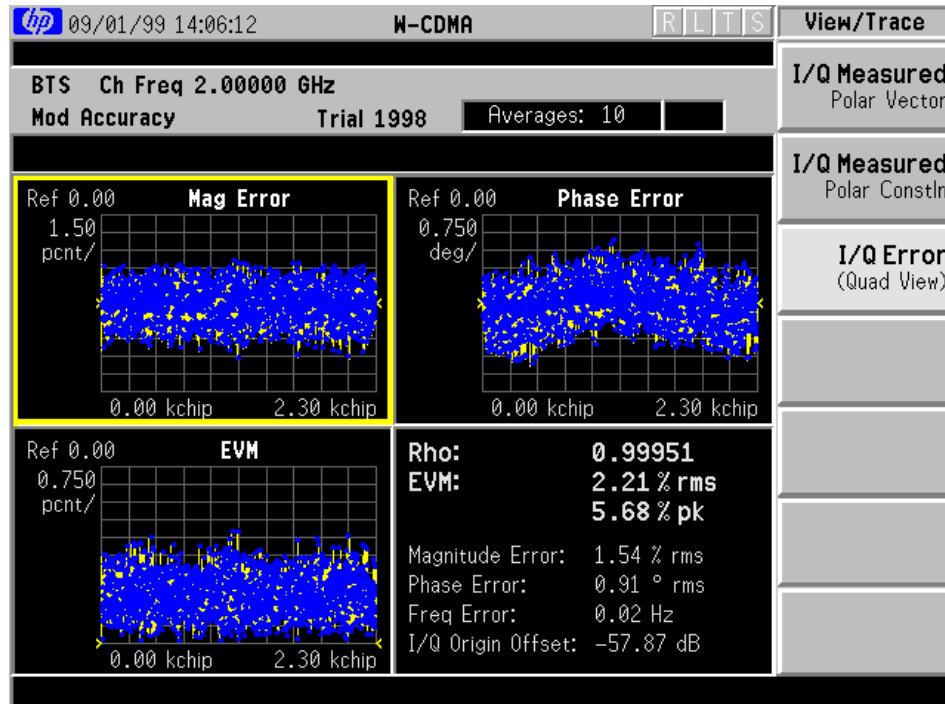

Any one of these windows can be selected using the **Next Window** key and made full size using the **Zoom** key.

Changing the Display

The **Display** key accesses the menu to allow the following selections for changing the graph displays of I/Q Measured Polar Vector and I/Q Error (Quad-View):

- **I/Q Points** - Allows you to specify the number of displayed points for the I/Q waveforms. The range is 1 to 4608 points with the points per chip fixed to 2. The default setting is 512 points.
- **Chip Dots** - Allows you to toggle the chip dot display between **On** and **Off**. The default setting is **On**.
- **+45 Degree Rotation** - Allows you to toggle the display rotation function between **On** and **Off**. If this is set to **On**, the I/Q polar constellation graph is rotated by +45 degrees to see a rectangular display. The default setting is **Off**.

When either **EVM**, **Phase Error**, or **Mag Error** window is active in the **I/Q Error (Quad-View)** display, the **Span X Scale** key accesses the menu to allow the following settings:

- **Scale/Div** - Allows you to set the horizontal scale by changing a chip value per division. The range is 1.000 to 256.00 chips per division with 0.001 chip resolution. The default setting is 230.30 chips per division, however, since **Scale Coupling** is defaulted to **On**, this value is automatically determined by the measurement results.
- **Ref Value** - Allows you to set the chip reference value ranging from 0.000 to 2560.0 chips. The default setting is 0.000 chip, however, since **Scale Coupling** is defaulted to **On**, this value is automatically determined by the measurement results.
- **Ref Position** - Allows you to set the reference position to either **Left**, **Ctr** (center) or **Right**. The default setting is **Left**.
- **Scale Coupling** - Allows you to toggle the scale coupling function between **On** and **Off**. The default setting is **On**. This function automatically determines the scale per division and reference values by the measurement results.

When either **EVM** or **Mag Error** window is active in the **I/Q Error (Quad-View)** display, the **Amplitude Y Scale** key accesses the menu to allow the following settings:

- **Scale/Div** - Allows you to set the vertical scale by changing the value per division. The range is 0.100 to 50.0% per division. The default setting is 5.00%, however, since **Scale Coupling** is defaulted to **On**, this value is automatically determined by the measurement result.
- **Ref Value** - Allows you to set the reference value ranging from 0.00 to 500.0%. The default setting is 0.00%, however, since **Scale Coupling** is defaulted to **On**, this value is automatically determined by the measurement results.
- **Ref Position** - Allows you to set the reference position to either **Top**, **Ctr** (center) or **Bot** (bottom). For the **EVM** graph, the default setting is **Bot**. For the **Mag Error** graph, the default setting is **Ctr**.
- **Scale Coupling** - Allows you to toggle the scale coupling function between **On** and **Off**. The default setting is **On**. This function automatically determines the scale per division and reference values by the measurement results.

When the `Phase Error` window is active in the `I/Q Error (Quad-View)` display, the `Amplitude Y Scale` key accesses the menu to allow the following settings:

- **Scale/Div** - Allows you to set the vertical scale by changing the value per division. The range is 0.01 to 3600 degrees. The default setting is 5.00 degrees per division, however, since **Scale Coupling** is defaulted to **On**, this value is automatically determined by the measurement results.
- **Ref Value** - Allows you to set the reference value ranging from -36000 to 36000 degrees. The default setting is 0.00 degrees, however, since **Scale Coupling** is defaulted to **On**, this value is automatically determined by the measurement results.
- **Ref Position** - Allows you to set the reference position to either **Top**, **Ctr** (center) or **Bot** (bottom). The default setting is **Ctr**.
- **Scale Coupling** - Allows you to toggle the scale coupling function between **On** and **Off**. The default setting is **On**. This function automatically determines the scale per division and reference values by the measurement results.

Using the Markers

The **Marker** front-panel key accesses the menu to configure the markers depending on the display selected.

- **Select** - Allows you to activate up to four markers with the corresponding numbers, respectively. The selected number is underlined and its function is defined by pressing the **Function** key. The default setting is 1.
- **Normal** - Allows you to activate the selected marker to read the magnitude or phase error and the number of chips of the marker position on the selected trace, for example, which is controlled by the **RPG** knob.
- **Delta** - Allows you to read the differences in the magnitude or phase errors and the number of chips between the selected marker and the next.
- **Function** - Allows you to set the selected marker function to **Band Power**, **Noise**, or **Off**. The default setting is **Off**. The **Band Power** and **Noise** functions are not available for this measurement.
- **Trace** - Allows you to place the selected marker on the **EVM**, **Phase Error**, or **Mag Error** trace. The default setting is **EVM**.
- **Off** - Allows you to turn off the selected marker.
- **Shape** - Allows you to access the menu to set the selected marker shape to **Diamond**, **Line**, **Square**, or **Cross**. The default setting is **Diamond**.
- **Marker All Off** - Allows you to turn off all of the markers.

Troubleshooting Hints

A poor phase error often indicates a problem at the I/Q baseband generator, filters, and/or modulator in the transmitter circuitry of the UUT. The output amplifier in the transmitter can also create distortion that causes unacceptably high phase error. In a real system, a poor phase error will reduce the ability of a receiver to correctly demodulate the received signal, especially in marginal signal conditions.

Making the Spectrum (Frequency Domain) Measurement

Purpose

The spectrum measurement provides spectrum analysis capability for the instrument. The control of the measurement was designed to be familiar to those who are accustomed to using swept spectrum analyzers.

This measurement is FFT (Fast Fourier Transform) based. The FFT-specific parameters are located in the **Advanced** menu. Also available under basic mode spectrum measurements is an I/Q window, which shows the I and Q signals in parameters of voltage versus time. The advantage of having an I/Q view available while in the spectrum measurement is that it allows you to view complex components of the same signal without changing settings or measurements.

Measurement Method

The transmitter tester uses digital signal processing to sample the input signal and convert it to the frequency domain. With the instrument tuned to a fixed center frequency, samples are digitized at a high rate, converted to I and Q components with DSP hardware, and then converted to the frequency domain with FFT software.

Making the Measurement

NOTE

The factory default parameters provide a good starting point. You will likely want to change some of the settings. Press **Meas Setup, More (1 of 2), Restore Meas Defaults** at any time to return all parameters for the current measurement to their default settings.

Press **Measure, Spectrum (Freq Domain)** to immediately make Spectrum (Frequency Domain) the active measurement.

To change any of the measurement parameters from the factory default values, refer to the “Changing the Measurement Setup” section for this measurement.

Results

A display with both a spectrum window and an I/Q Waveform window will appear when you activate a spectrum measurement. Use the **Next Window** key to select a window, and the **Zoom** key to enlarge a window.

Figure 5-14 Spectrum Measurement - Spectrum and I/Q Waveform View

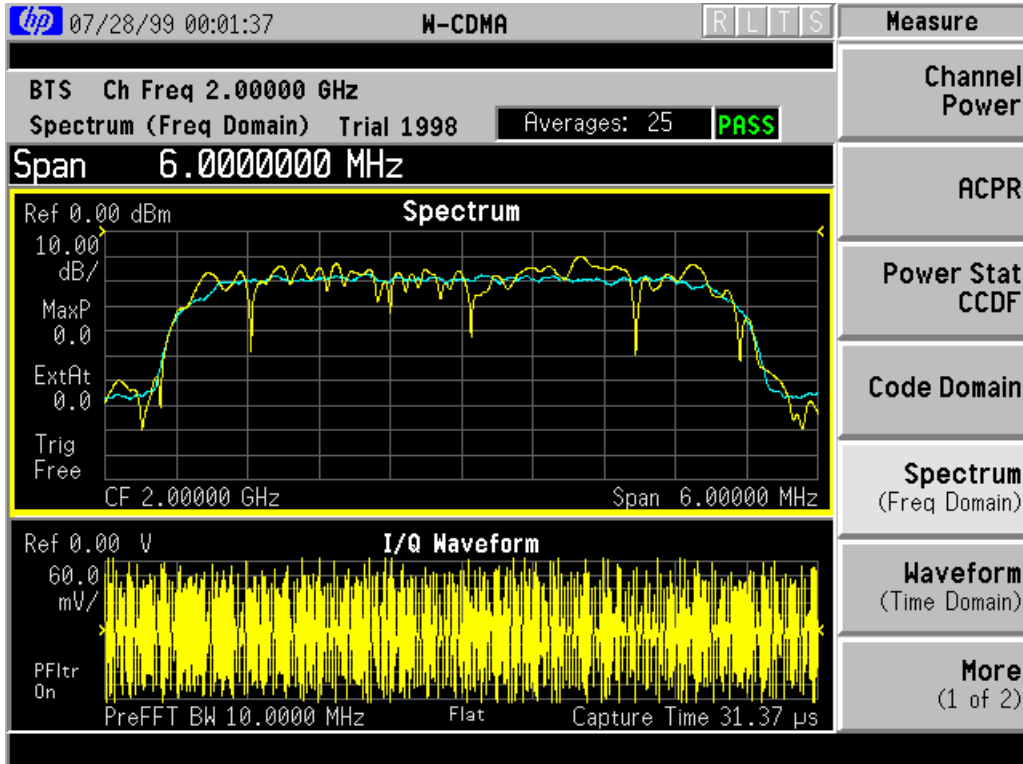

Changing the Measurement Setup

Table 3 Spectrum (Frequency Domain) Measurement Defaults

Measurement Parameter	Factory Default Condition
Res BW	20.0000 kHz (Auto)
Averaging:	
Avg Number	25 On
Avg Mode	Exp
Avg Type	Log-Pwr Avg (Video)
Trigger Source	Free Run (Immediate)
Measurement Time (Service mode only)	1.0 ms (Auto)
Spectrum Window:	
Span	1.00000 MHz
Scale/Div - Amplitude Y Scale	10.00 dB
I/Q Waveform Window:	
Capture Time	188.00 μ s
Scale/Div - Amplitude Y Scale	60 mV
Advanced	
Pre-ADC BPF	On
Pre-FFT Filter	Flat
Pre-FFT BW	1.55000 MHz (Auto)
FFT Window	Flat Top (High AmptdAcc)
FFT Size:	
Length Control	Auto
Min Points/RBW	1.300000
Window Length	706
FFT Length	4096
ADC Range	Auto Peak
Data Packing	Auto
ADC Dither	Auto
Decimation	0 (Auto)
IF Flatness	On

NOTE

Parameters under the **Advanced** key seldom need to be changed. Any changes from the default advanced values may result in invalid measurement data.

Make sure the **Spectrum (Freq Domain)** measurement is selected under the **Measure** menu. Press the **Meas Setup** key to access a menu which allows you to modify the averaging, and trigger source for this measurement (as described in the “Measurement Setup” section). In addition, the following parameters can be modified:

- **Span** - This key allows you to modify the frequency span. Changing the span causes the bandwidth to change automatically, and will affect data acquisition time.
- **Res BW** - This feature sets the resolution bandwidth for the FFT, and allows manual or automatic settings. A narrower bandwidth will result in a longer data acquisition time. In Auto mode the resolution bandwidth is set to Span/50 (2% of the span).
- **Advanced** - The following FFT advanced features should be used only if you are familiar with their operation. Changes from the default values may result in invalid data.

Pre-ADC BPF - This key allows you to toggle the pre-ADC bandpass filter to On or Off states. The pre-ADC bandpass filter is useful for rejecting nearby signals, so that sensitivity within the span range can be improved by increasing the ADC range gain.

Pre-FFT Fltr - Allows you to toggle between **Flat** (flat top) and **Gaussian**. The pre-FFT filter defaults to a flat top filter which has better amplitude accuracy. The Gaussian filter has better pulse response.

Pre-FFT BW - The Pre-FFT bandwidth allows you to select between a manual or an automatic setting. The pre FFT-bandwidth filter can be set between 1 Hz and 10 MHz. In Auto mode this bandwidth is nominally 50% wider than the span. This bandwidth determines the ADC sampling rate.

FFT Window - Allows you to access the following selection menu. Unless you are familiar with FFT windows, use the flat top filter (the default filter).

- **Flat Top** - Selects a filter for best amplitude accuracy, by reducing scalloping error.
- **Uniform** - You can select to have no window active by using the uniform setting.
- **Hanning**
- **Hamming**
- **Gaussian** - Selects a gaussian filter with an alpha of 3.5.

- **Blackman**
- **Blackman Harris**
- **K-B 70dB / 90dB/ 110dB (Kaiser-Bessel)** - Allows selection of Kaiser-Bessel filters with sidelobes of -70, -90, or -110 dBc.

FFT Size - This menu contains the following features:

- **Length Ctrl** - This feature allows you to set the FFT and window lengths either automatically or manually.
- **Min Pts in RBW** - This feature allows you to set the minimum number of data points that will be used inside the resolution bandwidth. This adjustment is only available if the **Length Ctrl** key is set to Auto.
- **Window Length** - This feature allows you to enter the FFT window length ranging from 8 to 1048576. This length represents the actual quantity of I/Q samples that are captured for processing by the FFT. This value can only be entered if length control is set to Manual.
- **FFT Length** - This feature allows you to enter the FFT length in the number of captured samples, ranging from 4096 to 1048576. The FFT length setting is automatically limited so that it is equal or greater than the FFT window length setting. Any amount greater than the window length is implemented by zero-padding. This value can be entered only if length control is set to Man (manual).

ADC Range - Allows you to access the following selection menu to define one of the following ADC ranging functions:

- **Auto** - Select this to set the ADC range automatically. For most FFT spectrum measurements, the auto feature should not be selected. An exception is when measuring a signal which is “bursty”, in which case auto can maximize the time domain dynamic range, if FFT results are less important to you than time domain results.
- **Auto Peak** - Select this to set the ADC range automatically to the peak signal level. Auto peak is a compromise that works well for both CW and burst signals.
- **AutoPeakLock** - Select this to hold the ADC range automatically at the peak signal level. Auto peak lock is more stable than auto peak for CW signals, but should not be used for “bursty” signals.
- **Manual** - Allows you to access the selection menu: **-6 dB, 0 dB, +6 dB, +12 dB, +18 dB, +24 dB**, to set the ADC range level. Also note that manual ranging is best for CW signals.

Data Packing - Allows you to access the following selection menu to define one of the following data packing methods:

- **Auto** - Data is automatically packed. This is the default setting and most recommended.
- **Short (16 bit)** - Data is packed by every 16 bits.
- **Medium (24 bit)** - Data is packed by every 24 bits.
- **Long (32 bit)** - Data is packed by every 32 bits.

ADC Dither - Allows you to toggle the ADC dither function between **Auto**, **On**, and **Off**. When set to auto (the default), ADC dither will be activated when a narrow bandwidth is being measured, and deactivated when a wide bandwidth is being measured. “ADC dither” refers to the introduction of noise to the digitized steps of the analog-to-digital converter; the result is an improvement in amplitude accuracy. Use of the ADC dither, however, reduces dynamic range by approximately 3 dB.

Decimation - Allows you to toggle the decimation function between **Auto** and **Man**, and to set the decimation value. **Auto** is the preferred setting, and the only setting that guarantees alias-free FFT spectrum measurements. If you are familiar with the decimation feature, you can change the decimation value by setting to **Man**, but be aware that aliasing can result in higher values.

IF Flatness - Allows you to toggle between **On** and **Off**. When toggled to **On** (the default), the IF flatness feature causes background amplitude corrections to be performed on the FFT spectrum. The **Off** setting is used for adjustment and troubleshooting the transmitter tester.

Changing the View

View/Trace menu keys are used to activate a view of a measurement with preset X and Y scale parameters, called a “window”. Using the X and Y Scale keys you can then modify these parameter settings. You can also activate specific traces, using the **Trace Display** menu key.

Windows Available for Spectrum Measurements

The spectrum and the I/Q windows can be viewed at the same time, or individually. You can use the **Next Window** and **Zoom** keys to move between these different views.

Spectrum window Select this window if you want to view frequency and power. Changes to frequency span or power will sometimes affect data acquisition.

I/Q Waveform window. Select this window to view the I and Q signal characteristics of the current measurement in parameters of voltage and time.

NOTE For the widest spans the I/Q window becomes just “ADC time domain samples”, because the I/Q down-conversion is no longer in effect.

Using the Markers

The **Marker** front-panel key accesses the menu to configure the markers. If you want to use the marker function in the I/Q window, press **View/Trace, I/Q Waveform, Marker, Trace, IQ Waveform**.

- **Select 1 2 3 4** - Allows you to activate up to four markers with the corresponding numbers, respectively. The selected number is underlined and its function is defined by pressing the **Function** key. The default is 1.
- **Normal** - Allows you to activate the selected marker to read the frequency and amplitude of the marker position on the spectrum trace, for example, which is controlled by the **RPG** knob.
- **Delta** - Allows you to read the differences in frequencies and amplitudes between the selected marker and the next.
- **Function Off** - Allows you to define the selected marker function to be **Band Power, Noise, or Off**. The default is **Off**. If set to **Band Power**, you need to select **Delta**.
- **Trace Spectrum** - Allows you to place the selected marker on the **Spectrum, Spectrum Avg, or I/Q Waveform** trace. The default is **Spectrum**.
- **Off** - Allows you to turn off the selected marker.
- **Shape Diamond** - Allows you to access the menu to define the selected marker shape to be a **Diamond, Line, Square, or Cross**. The default is a **Diamond**.
- **Marker All Off** - Allows you to turn off all of the markers.

The front panel **Search** key performs a peak search when pressed. A marker will automatically be activated at the highest peak.

Band Power

A band power measurement using the markers calculates the average power between two adjustable markers. To make a band power measurement:

Press the **Marker** key.

Press **Trace, Spectrum** to activate a marker on the instantaneous spectrum signal. Press the **Spectrum Avg** key to activate a marker on the average spectrum trace.

Press **Function, Band Power**.

Two marker lines are activated at the extreme left side of the horizontal scale. Press **Normal** and move marker 1 to the desired place by rotating the **RPG** knob.

Press **Delta** to bring marker 2 to the same place as marker 1.

Move marker 1 to the other desired position by rotating the **RPG** knob. Band power measures the average power between the two markers. When the band power markers are active, the results are shown in the results window as Mean Pwr (Between Mks). When the band power function is off the results window reads Mean Pwr (Entire Trace).

Troubleshooting Hints

Changes made by the user to advanced spectrum settings, particularly to ADC range settings, can inadvertently result in spectrum measurements that are invalid and cause error messages to appear. Care needs to be taken when using advanced features.

Making the Waveform (Time Domain) Measurement

Purpose

The waveform measurement is a generic measurement for viewing waveforms in the time domain. This measurement is how the instrument performs the zero span functionality found in traditional spectrum analyzers. Also available under basic mode waveform measurements is an I/Q window, which shows the I and Q signal in parameters of voltage and time. The advantage of having an I/Q view available while in the waveform measurement is that it allows you to view complex components of the same signal without changing settings or measurements.

The waveform measurement can be used to perform general purpose power measurements to a high degree of accuracy.

Measurement Method

The transmitter tester makes repeated power measurements at a set frequency, similar to the way a swept-tuned spectrum analyzer makes zero span measurements. The input analog signal is converted to a digital signal, which then is processed into a representation of a waveform measurement. The transmitter tester relies on a high rates of sampling to create an accurate representation of a time domain signal.

Making the Measurement

NOTE

The factory default parameters provide a good starting point. You will likely want to change some of the settings. Press **Meas Setup, More (1 of 2), Restore Meas Defaults** at any time to return all parameters for the current measurement to their default settings.

Press **Measure, Waveform (Time Domain)** to immediately make Waveform (Time Domain) the active measurement.

To change any of the measurement parameters from the factory default values, refer to the “Changing the Measurement Setup” section for this measurement.

Results

Figure 5-15 Waveform (Time Domain) Measurement - RF Envelope View

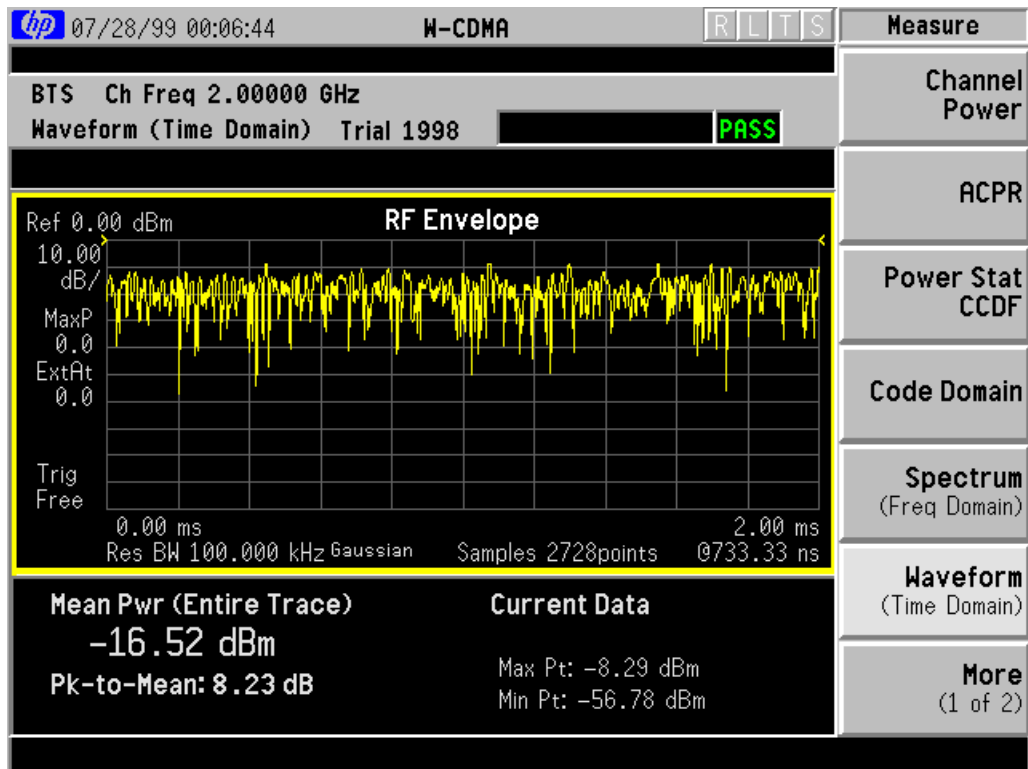

Changing the Measurement Setup

Table 4 Waveform (Time Domain) Measurement Defaults

Measurement Parameter	Factory Default Condition
View/Trace	RF Envelope
Sweep Time	2.000 ms
Res BW	100.000 kHz
Averaging:	
Avg Number	10 Off
Avg Mode	Exp
Avg Type	Pwr Avg (RMS)
Trigger Source	Free Run (Immediate)
RF Envelope Window:	
Amplitude Y Scale	
Scale/Div	10.00 dB
Reference	0.00 dBm (Top)
I/Q Waveform Window:	
Amplitude Y Scale	
Scale/Div	100.0 mv
Reference	0.00 V (Ctr)
Advanced	
Pre-ADC BPF	Off
RBW Filter	Gaussian
ADC Range	Auto
Data Packing	Auto
ADC Dither	Off
Decimation	Off

NOTE Parameters that are under the **Advanced** key seldom need to be changed. Any changes from the default values may result in invalid measurement data.

Make sure the **Waveform (Time Domain)** measurement is selected under the **Measure** menu. Press the **Meas Setup** key to access a menu which allows you to modify the averaging, and trigger source for this measurement (as described in the “Measurement Setup” section). In addition, the following parameters can be modified:

- **Sweep Time** - This key allows you to select the measurement acquisition time. It is used to specify the length of the time capture record. Values between 10 μ s and 50 s can be entered, depending upon the resolution bandwidth setting.
- **Res BW** - This key sets the measurement bandwidth. A larger bandwidth results in a larger number of acquisition points and reduces the maximum allowed for sweep time. You can enter values between 10 Hz. and 7.5 MHz.
- **Advanced** menu key. This key accesses the features listed below.

Pre-ADC BPF - This key allows you to toggle the pre-ADC bandpass filter to On or Off states. The pre-ADC bandpass filter is useful for rejecting nearby signals, so that sensitivity within the span range can be improved by increasing the ADC range gain

RBW Filter - This key toggles to select a flat top or a Gaussian resolution bandwidth filter. A Gaussian filter provides more even time domain response, particularly for bursts. A flat top filter provides a flatter bandwidth but is less accurate for pulse responses. A flat top filter also requires less memory and allows longer data acquisition times. For most waveform applications, the Gaussian filter is recommended, and it is the default filter for waveform measurements.

ADC Range -.Allows you to access the following selection menu to define one of the following ADC ranging functions:

- **Auto** - This key causes the instrument to automatically adjust the signal range for optimal measurement results.
- **AutoPeak** - This key causes the instrument to continuously seek the highest peak signal.
- **AutoPeakLock** - This key causes the instrument to adjust the range for the highest peak signal it identifies, and retains the range settings determined by that peak signal, even when the peak signal is no longer present.
- **Manual** - Allows you to access the selection menu: **-6 dB, 0 dB, +6 dB, +12 dB, +18 dB, +24 dB**, to set the ADC range level. Also note that manual ranging is best for CW signals.

Data Packing - Allows you to access the following selection menu to define one of the following data packing methods:

- **Auto** - Data is automatically packed. This is the default setting and most recommended.

- **Short (16 bit)** - Data is packed by every 16 bits.
- **Medium (24 bit)** - Data is packed by every 24 bits.
- **Long (32 bit)** - Data is packed by every 32 bits.

ADC Dither - Allows you to toggle the ADC dither function between **On** and **Off**. Activation of the ADC dither results in better amplitude linearity and resolution in low level signals. However, it also results in reduced dynamic range. ADC dither is set to **Off** by default.

Decimation - Allows you to toggle the decimation function between **On** and **Off** and to set the decimation value. Decimation allows longer acquisition times for a given bandwidth by eliminating data points. Long time captures can be limited by the transmitter tester data acquisition memory. Decimation numbers 1 to 4 describe the factor by which the number of points are reduced. A decimation figure of 1, which results in no data point reduction, is the default.

Changing the View

The **View/Trace** menu keys are used to activate a view of a measurement with preset X and Y scale parameters; this view is called a “window.” Using the X and Y scale keys, you can then modify these parameters. You can also activate traces, using the **Traces Display** menu key.

Windows Available for Waveform Measurements

RF Envelope window. Select this window if you want to view power (in dBm) vs. time. Remember that data acquisition will be affected when you change the sweep time.

I/Q Waveform window. Select this window to view the I and Q signal characteristics of the current measurement in parameters of voltage and time.

Using the Markers

The **Marker** front-panel key accesses the menu to configure the markers. If you want to use the marker function in the I/Q window, press **View/Trace, I/Q Waveform, Marker, Trace, IQ Waveform**.

- **Select 1 2 3 4** - Allows you to activate up to four markers with the corresponding numbers, respectively. The selected number is underlined and its function is defined by pressing the **Function** key. The default is 1.
- **Normal** - Allows you to activate the selected marker to read the frequency and amplitude of the marker position on the spectrum trace, for example, which is controlled by the **RPG** knob.
- **Delta** - Allows you to read the differences in frequencies and amplitudes between the selected marker and the next.
- **Function Off** - Allows you to define the selected marker function to be **Band Power**, **Noise**, or **Off**. The default is **Off**. If set to **Band Power**, you need to select **Delta**.
- **Trace Spectrum** - Allows you to place the selected marker on the **Spectrum**, **Spectrum Avg**, or **I/Q Waveform** trace. The default is **Spectrum**.
- **Off** - Allows you to turn off the selected marker.
- **Shape Diamond** - Allows you to access the menu to define the selected marker shape to be a **Diamond**, **Line**, **Square**, or **Cross**. The default is a **Diamond**.
- **Marker All Off** - Allows you to turn off all of the markers.

The front panel **Search** key performs a peak search when pressed. A marker will automatically be activated at the highest peak.

NOTE

In the Waveform measurement, the Mean Pwr (Entire Trace) value plus the Pk-to-Mean value will sum to equal the current Max Pt. value as shown in the data window below the RF Envelope display. If you do a marker peak search (**Search**) with averaging turned off, the marker will find the same maximum point. However, if you turn averaging on, the Pk-to-Mean value will use the highest peak found for any acquisition during averaging, while the marker peak will look for the peak of the display, which is the result of n-averages. This will usually result in differing values for the maximum point.

Band Power

A band power measurement using the markers calculates the average power between two adjustable markers. To make a band power measurement:

Press the **Marker** key.

Press **Function, Band Power**.

Two marker lines are activated at the extreme left side of the horizontal scale. Press **Normal** and move marker 1 to the desired place by rotating the **RPG** knob.

Press **Delta** to bring marker 2 to the same place as marker 1.

Move marker 1 to the other desired position by rotating the **RPG** knob. Band power measures the average power between the two markers. When the band power markers are active, the results are shown in the results window as Mean Pwr (Between Mks). When the band power function is off the results window reads Mean Pwr (Entire Trace).

Troubleshooting Hints

Changes made by the user to advanced waveform settings can inadvertently result in measurements that are invalid and cause error messages to appear. Care needs to be taken when using advanced features.